

LG

Multi V Outdoor Unit

Cooling only

MFL72138802

TOTAL HVAC SOLUTION PROVIDER

ENGINEERING PRODUCT DATA BOOK

Multi V Outdoor Unit General Information

Model Line Up

1. Model Line Up

Product	Phase	Chassis	Capacity Index	Model Name
			kW	
Multi V S	1	U24A	8.2	ARUV030GSD6 [ARUV030GSD6]
		U36A	11	ARUV040GSD6 [ARUV040GSD6]
			14.5	ARUV050GSD6 [ARUV050GSD6]
			16	ARUV060GSD6 [ARUV060GSD6]

* The capacity index may differ from actual capacity values.

Product Data

Multi V S

Multi V S

- 1. Specifications**
- 2. List of Functions**
- 3. Accessory Compatibility List**
- 4. Dimensions**
- 5. Piping Diagrams**
- 6. Wiring Diagrams**
- 7. Capacity Tables**
- 8. Capacity Correction Factor**
- 9. Operation Limits**
- 10. Sound Levels**

1. Specifications

1.1 Product

ARUV030GSD6 [ARUV030GSD6]

Category		Unit	Specification
Major	Minor		
Classification	Chassis	-	U24A
	Combination Unit (1)	-	-
	Combination Unit (2)	-	-
	Combination Unit (3)	-	-
	Combination Unit (4)	-	-
Power Supply	Case 1	V, Phase, Hz	220, 1, 60
	Limit Range of Voltage(Case 1)	V	198~242
	Case 2	V, Phase, Hz	220-230-240, 1, 50
	Limit Range of Voltage(Case 2)	V	198~264
Cooling Capacity	Rated	kW	8.20
		Btu/h	27,978
Heating Capacity	Rated	kW	-
		Btu/h	-
Power Input(Cooling)	Rated	kW	2.32
Power Input(Heating)	Rated	kW	-
Efficiency	EER(Rated)	W/W	3.53
	COP(Rated)	W/W	-
Power Factor(Cooling/Heating)	Rated	-	-
Outdoor Fan	Type	-	propeller
	Air Flow Rate(High)	m ³ /min	50×1
	Max. External Static Pressure	Pa	-
	Discharge direction(Side / Top)	-	Side
Outdoor Fan Motor	Type	-	BLDC
	Drive	-	DC Inverter
	Output	W x No.	85×1
Compressor	Type	-	Rotary
	Piston Displacement	cm ³ /rev	20.8
	Number of Revolution	rev./min	-
	Motor Output	W x No.	1,500 × 1
	Starting Method	-	DC Inverter Starting
	Oil Type	-	FW68L
Heat Exchanger	Type	-	Fin & Tube
	No.	-	1
	Fin Type	-	Wide Louver Plus
Dimensions	Net(W x H x D)	mm	870 x 650 x 330
	Shipping(W x H x D)	mm	1,041 x 693 x 456
Weight	Net	kg	44.0
	Shipping	kg	48.0
Exterior	Color	-	Warm Gray
	RAL (Classic)	-	-
Protection Device	High Pressure Prevention	-	O
	Frost Prevention	-	-
	Discharge Temperature Control	-	O
	Compressor/Fan Protection	-	O
	Inverter Protection	-	O
Refrigerant	Type	-	R410A
	Precharged Amount	kg	1.0
	t-CO ₂ eq.	-	-
	Control Type	-	Electronic Expansion Valve

1. Specifications

Category		Unit	Specification
Major	Minor		
Connecting Pipe	Liquid	mm(inch)	Φ9.52 (3/8)
	Gas	mm(inch)	Φ15.88 (5/8)
	Low Pressure Gas (Heat Recovery)	mm(inch)	-
	High Pressure Gas (Heat Recovery)	mm(inch)	-
Piping Connection Type	Liquid	-	Flare
	Gas	-	Flare
	Low Pressure Gas (Heat Recovery)	-	-
	High Pressure Gas (Heat Recovery)	-	-
Sound Pressure Level (Outdoor Unit)	Cooling / Heating	dB(A)	53.0 / -
Measurement Standard (Pressure Level)	-	-	-
Sound Power Level (Outdoor Unit)	Cooling / Heating	dB(A)	-
Measurement Standard (Power Level)	-	-	-
Connecting Cable	Communication Cable(VCTF-SB)	mm ² × cores	1.0~1.5 x 2
Electrical Characteristic	Minimum Circuit Amperes (MCA)	A	18.0
	Maximum Fuse Amperes (MFA)	A	20.0
	Total Over Current Amperes (TOCA)	A	19.8
	Comp_Maximum Starting Current (MSC)	A	-
	Comp_Rated Load Amperes (Cooling)	A	13.2
	Comp_Rated Load Amperes (Heating)	A	-
	Outdoor Fan Motor_Full Load Amperes (FLA)	A	0.4
Connectable indoor units number	Max. (Conditional)	Units	8

Note

- Due to our policy of innovation some specifications may be changed without notification.
- Wiring cable size must comply with the applicable local and national codes. And "Electric characteristics" should be considered for electrical work and design. Especially the power cable and circuit breaker should be selected in accordance with that.
- Power factor could vary less than ±1% according to the operating conditions.
- Sound level values are depend on the ambient conditions and values are normally higher in actual operation.
- This product contains Fluorinated greenhouse gases.
- Voltage supplied to the unit terminals should be within the minimum and maximum range.
- Maximum allowable voltage unbalance between phase is 2%.
- MSC means the Max. current during the starting of compressor.
- MSC and RLA are measured as the compressor only test condition.
- OFM are measured as the outdoor unit test condition.
- TOCA means the total over current value of each outdoor unit.
- Select the wire size based on the larger value among MCA or TOCA.
- MFA is used to select the circuit breaker and ground fault circuit interrupter, and all installation site must require attachment of an earth leakage breaker. [circuit breaker type is ELCB(Earth Leakage Circuit Breaker)].
- Performances are based on the following conditions :
 - Cooling : Indoor Ambient Temp. 27°CDB / 19°CWB, Outdoor Ambient Temp. 35°CDB / 24°CWB
 - Interconnected Pipe Length is 7.5m and difference of Elevation (Outdoor ~ Indoor Unit) is 0m.

1. Specifications

ARUV040GSD6 [ARUV040GSD6]

Category		Unit	Specification
Major	Minor		
Classification	Chassis	-	U36A
	Combination Unit (1)	-	-
	Combination Unit (2)	-	-
	Combination Unit (3)	-	-
	Combination Unit (4)	-	-
Power Supply	Case 1	V, Phase, Hz	220, 1, 60
	Limit Range of Voltage(Case 1)	V	198~242
	Case 2	V, Phase, Hz	220-230-240, 1, 50
	Limit Range of Voltage(Case 2)	V	198~264
Cooling Capacity	Rated	kW	11.00
		Btu/h	37,532
Heating Capacity	Rated	kW	-
		Btu/h	-
Power Input(Cooling)	Rated	kW	2.76
Power Input(Heating)	Rated	kW	-
Efficiency	EER(Rated)	W/W	3.99
	COP(Rated)	W/W	-
Power Factor(Cooling/Heating)	Rated	-	-
Outdoor Fan	Type	-	propeller
	Air Flow Rate(High)	m ³ /min	60×1
	Max. External Static Pressure	Pa	-
	Discharge direction(Side / Top)	-	side
Outdoor Fan Motor	Type	-	BLDC
	Drive	-	DC Inverter
	Output	W x No.	124×1
Compressor	Type	-	Rotary
	Piston Displacement	cm ³ /rev	20.8
	Number of Revolution	rev./min	-
	Motor Output	W x No.	1,500 × 1
	Starting Method	-	DC Inverter Starting
	Oil Type	-	FW68L
Heat Exchanger	Type	-	Fin & Tube
	No.	-	1
	Fin Type	-	Wide Louver Plus
Dimensions	Net(W x H x D)	mm	950 x 834 x 330
	Shipping(W x H x D)	mm	1,140 x 918 x 461
Weight	Net	kg	57.0
	Shipping	kg	64.0
Exterior	Color	-	Warm Gray
	RAL (Classic)	-	-
Protection Device	High Pressure Prevention	-	O
	Frost Prevention	-	-
	Discharge Temperature Control	-	O
	Compressor/Fan Protection	-	O
	Inverter Protection	-	O
Refrigerant	Type	-	R410A
	Precharged Amount	kg	1.0
	t-CO ₂ eq.	-	-
	Control Type	-	Electronic Expansion Valve
Connecting Pipe	Liquid	mm(inch)	Φ9.52 (3/8)
	Gas	mm(inch)	Φ15.88 (5/8)

1. Specifications

Category		Unit	Specification
Major	Minor		
Connecting Pipe	Low Pressure Gas (Heat Recovery)	mm(inch)	-
	High Pressure Gas (Heat Recovery)	mm(inch)	-
Piping Connection Type	Liquid	-	Flare
	Gas	-	Flare
	Low Pressure Gas (Heat Recovery)	-	-
	High Pressure Gas (Heat Recovery)	-	-
Sound Pressure Level (Outdoor Unit)	Cooling / Heating	dB(A)	52.0 / -
Measurement Standard (Pressure Level)	-	-	-
Sound Power Level (Outdoor Unit)	Cooling / Heating	dB(A)	-
Measurement Standard (Power Level)	-	-	-
Connecting Cable	Communication Cable(VCTF-SB)	mm ² × cores	1.0~1.5 x 2
Electrical Characteristic	Minimum Circuit Amperes (MCA)	A	19.3
	Maximum Fuse Amperes (MFA)	A	30.0
	Total Over Current Amperes (TOCA)	A	21.3
	Comp_Maximum Starting Current (MSC)	A	-
	Comp_Rated Load Amperes (Cooling)	A	15.9
	Comp_Rated Load Amperes (Heating)	A	-
	Outdoor Fan Motor_Full Load Amperes (FLA)	A	0.5
Connectable indoor units number	Max. (Conditional)	Units	9

Note

- Due to our policy of innovation some specifications may be changed without notification.
- Wiring cable size must comply with the applicable local and national codes. And "Electric characteristics" should be considered for electrical work and design. Especially the power cable and circuit breaker should be selected in accordance with that.
- Power factor could vary less than ±1% according to the operating conditions.
- Sound level values are depend on the ambient conditions and values are normally higher in actual operation.
- This product contains Fluorinated greenhouse gases.
- Voltage supplied to the unit terminals should be within the minimum and maximum range.
- Maximum allowable voltage unbalance between phase is 2%.
- MSC means the Max. current during the starting of compressor.
- MSC and RLA are measured as the compressor only test condition.
- OFM are measured as the outdoor unit test condition.
- TOCA means the total over current value of each outdoor unit.
- Select the wire size based on the larger value among MCA or TOCA.
- MFA is used to select the circuit breaker and ground fault circuit interrupter, and all installation site must require attachment of an earth leakage breaker. [circuit breaker type is ELCB(Earth Leakage Circuit Breaker)].
- Performances are based on the following conditions :
 - Cooling : Indoor Ambient Temp. 27°CDB / 19°CWB, Outdoor Ambient Temp. 35°CDB / 24°CWB
 - Interconnected Pipe Length is 7.5m and difference of Elevation (Outdoor ~ Indoor Unit) is 0m.

1. Specifications

ARUV050GSD6 [ARUV050GSD6]

Category		Unit	Specification
Major	Minor		
Classification	Chassis	-	U36A
	Combination Unit (1)	-	-
	Combination Unit (2)	-	-
	Combination Unit (3)	-	-
	Combination Unit (4)	-	-
Power Supply	Case 1	V, Phase, Hz	220, 1, 60
	Limit Range of Voltage(Case 1)	V	198~242
	Case 2	V, Phase, Hz	220-230-240, 1, 50
	Limit Range of Voltage(Case 2)	V	198~264
Cooling Capacity	Rated	kW	14.50
		Btu/h	49,474
Heating Capacity	Rated	kW	-
		Btu/h	-
Power Input(Cooling)	Rated	kW	3.73
Power Input(Heating)	Rated	kW	-
Efficiency	EER(Rated)	W/W	3.89
	COP(Rated)	W/W	-
Power Factor(Cooling/Heating)	Rated	-	-
Outdoor Fan	Type	-	propeller
	Air Flow Rate(High)	m ³ /min	60 x 1
	Max. External Static Pressure	Pa	-
	Discharge direction(Side / Top)	-	Side
Outdoor Fan Motor	Type	-	BLDC
	Drive	-	DC Inverter
	Output	W x No.	124 x 1
Compressor	Type	-	Scroll
	Piston Displacement	cm ³ /rev	31.6
	Number of Revolution	rev./min	-
	Motor Output	W x No.	3,200 x 1
	Starting Method	-	-
	Oil Type	-	FW68L
Heat Exchanger	Type	-	Fin & Tube
	No.	-	1
	Fin Type	-	Louver
Dimensions	Net(W x H x D)	mm	950 x 834 x 330
	Shipping(W x H x D)	mm	1,140 x 918 x 461
Weight	Net	kg	67.0
	Shipping	kg	75.0
Exterior	Color	-	Warm Gray
	RAL (Classic)	-	-
Protection Device	High Pressure Prevention	-	O
	Frost Prevention	-	-
	Discharge Temperature Control	-	O
	Compressor/Fan Protection	-	O
	Inverter Protection	-	O
Refrigerant	Type	-	R410A
	Precharged Amount	kg	2.0
	t-CO ₂ eq.	-	-
	Control Type	-	Electronic Expansion Valve
Connecting Pipe	Liquid	mm(inch)	Φ9.52 (3/8)
	Gas	mm(inch)	Φ15.88 (5/8)

1. Specifications

Category		Unit	Specification
Major	Minor		
Connecting Pipe	Low Pressure Gas (Heat Recovery)	mm(inch)	-
	High Pressure Gas (Heat Recovery)	mm(inch)	-
Piping Connection Type	Liquid	-	Flare
	Gas	-	Flare
	Low Pressure Gas (Heat Recovery)	-	-
	High Pressure Gas (Heat Recovery)	-	-
Sound Pressure Level (Outdoor Unit)	Cooling / Heating	dB(A)	54.0 / -
Measurement Standard (Pressure Level)	-	-	-
Sound Power Level (Outdoor Unit)	Cooling / Heating	dB(A)	-
Measurement Standard (Power Level)	-	-	-
Connecting Cable	Communication Cable(VCTF-SB)	mm ² × cores	1.0~1.5 x 2
Electrical Characteristic	Minimum Circuit Amperes (MCA)	A	24.5
	Maximum Fuse Amperes (MFA)	A	30.0
	Total Over Current Amperes (TOCA)	A	27.0
	Comp_Maximum Starting Current (MSC)	A	-
	Comp_Rated Load Amperes (Cooling)	A	20.9
	Comp_Rated Load Amperes (Heating)	A	-
	Outdoor Fan Motor_Full Load Amperes (FLA)	A	0.5
Connectable indoor units number	Max. (Conditional)	Units	9

Note

- Due to our policy of innovation some specifications may be changed without notification.
- Wiring cable size must comply with the applicable local and national codes. And "Electric characteristics" should be considered for electrical work and design. Especially the power cable and circuit breaker should be selected in accordance with that.
- Power factor could vary less than ±1% according to the operating conditions.
- Sound level values are depend on the ambient conditions and values are normally higher in actual operation.
- This product contains Fluorinated greenhouse gases.
- Voltage supplied to the unit terminals should be within the minimum and maximum range.
- Maximum allowable voltage unbalance between phase is 2%.
- MSC means the Max. current during the starting of compressor.
- MSC and RLA are measured as the compressor only test condition.
- OFM are measured as the outdoor unit test condition.
- TOCA means the total over current value of each outdoor unit.
- Select the wire size based on the larger value among MCA or TOCA.
- MFA is used to select the circuit breaker and ground fault circuit interrupter, and all installation site must require attachment of an earth leakage breaker. [circuit breaker type is ELCB(Earth Leakage Circuit Breaker)].
- Performances are based on the following conditions :
 - Cooling : Indoor Ambient Temp. 27°CDB / 19°CWB, Outdoor Ambient Temp. 35°CDB / 24°CWB
 - Interconnected Pipe Length is 7.5m and difference of Elevation (Outdoor ~ Indoor Unit) is 0m.

1. Specifications

ARUV060GSD6 [ARUV060GSD6]

Category		Unit	Specification
Major	Minor		
Classification	Chassis	-	U36A
	Combination Unit (1)	-	-
	Combination Unit (2)	-	-
	Combination Unit (3)	-	-
	Combination Unit (4)	-	-
Power Supply	Case 1	V, Phase, Hz	220, 1, 60
	Limit Range of Voltage(Case 1)	V	198~242
	Case 2	V, Phase, Hz	220-230-240, 1, 50
	Limit Range of Voltage(Case 2)	V	198~264
Cooling Capacity	Rated	kW	16.00
		Btu/h	54,592
Heating Capacity	Rated	kW	-
		Btu/h	-
Power Input(Cooling)	Rated	kW	4.13
Power Input(Heating)	Rated	kW	-
Efficiency	EER(Rated)	W/W	3.87
	COP(Rated)	W/W	-
Power Factor(Cooling/Heating)	Rated	-	-
Outdoor Fan	Type	-	propeller
	Air Flow Rate(High)	m ³ /min	60 x 1
	Max. External Static Pressure	Pa	-
	Discharge direction(Side / Top)	-	Side
Outdoor Fan Motor	Type	-	BLDC
	Drive	-	DC Inverter
	Output	W x No.	124 x 1
Compressor	Type	-	Scroll
	Piston Displacement	cm ³ /rev	31.6
	Number of Revolution	rev./min	3,600
	Motor Output	W x No.	3,200 x 1
	Starting Method	-	-
	Oil Type	-	FW68L
Heat Exchanger	Type	-	Fin & Tube
	No.	-	1
	Fin Type	-	Louver
Dimensions	Net(W x H x D)	mm	950 x 834 x 330
	Shipping(W x H x D)	mm	1,140 x 918 x 461
Weight	Net	kg	67.0
	Shipping	kg	75.0
Exterior	Color	-	Warm Gray
	RAL (Classic)	-	-
Protection Device	High Pressure Prevention	-	O
	Frost Prevention	-	-
	Discharge Temperature Control	-	O
	Compressor/Fan Protection	-	O
	Inverter Protection	-	O
Refrigerant	Type	-	R410A
	Precharged Amount	kg	2.0
	t-CO ₂ eq.	-	-
	Control Type	-	Electronic Expansion Valve
Connecting Pipe	Liquid	mm(inch)	Φ9.52 (3/8)
	Gas	mm(inch)	Φ19.05 (3/4)

1. Specifications

Category		Unit	Specification
Major	Minor		
Connecting Pipe	Low Pressure Gas (Heat Recovery)	mm(inch)	-
	High Pressure Gas (Heat Recovery)	mm(inch)	-
Piping Connection Type	Liquid	-	Flare
	Gas	-	Flare
	Low Pressure Gas (Heat Recovery)	-	-
	High Pressure Gas (Heat Recovery)	-	-
Sound Pressure Level (Outdoor Unit)	Cooling / Heating	dB(A)	57.0 / -
Measurement Standard (Pressure Level)	-	-	-
Sound Power Level (Outdoor Unit)	Cooling / Heating	dB(A)	-
Measurement Standard (Power Level)	-	-	-
Connecting Cable	Communication Cable(VCTF-SB)	mm ² × cores	1.0~1.5 x 2
Electrical Characteristic	Minimum Circuit Amperes (MCA)	A	28.4
	Maximum Fuse Amperes (MFA)	A	40.0
	Total Over Current Amperes (TOCA)	A	31.3
	Comp_Maximum Starting Current (MSC)	A	-
	Comp_Rated Load Amperes (Cooling)	A	25.1
	Comp_Rated Load Amperes (Heating)	A	-
	Outdoor Fan Motor_Full Load Amperes (FLA)	A	0.5
Connectable indoor units number	Max. (Conditional)	Units	9

Note

- Due to our policy of innovation some specifications may be changed without notification.
- Wiring cable size must comply with the applicable local and national codes. And "Electric characteristics" should be considered for electrical work and design. Especially the power cable and circuit breaker should be selected in accordance with that.
- Power factor could vary less than ±1% according to the operating conditions.
- Sound level values are depend on the ambient conditions and values are normally higher in actual operation.
- This product contains Fluorinated greenhouse gases.
- Voltage supplied to the unit terminals should be within the minimum and maximum range.
- Maximum allowable voltage unbalance between phase is 2%.
- MSC means the Max. current during the starting of compressor.
- MSC and RLA are measured as the compressor only test condition.
- OFM are measured as the outdoor unit test condition.
- TOCA means the total over current value of each outdoor unit.
- Select the wire size based on the larger value among MCA or TOCA.
- MFA is used to select the circuit breaker and ground fault circuit interrupter, and all installation site must require attachment of an earth leakage breaker. [circuit breaker type is ELCB(Earth Leakage Circuit Breaker)].
- Performances are based on the following conditions :
 - Cooling : Indoor Ambient Temp. 27°CDB / 19°CWB, Outdoor Ambient Temp. 35°CDB / 24°CWB
 - Interconnected Pipe Length is 7.5m and difference of Elevation (Outdoor ~ Indoor Unit) is 0m.

2. List of Functions

ARUV030GSD6 [ARUV030GSD6], ARUV040GSD6 [ARUV040GSD6], ARUV050GSD6 [ARUV050GSD6], ARUV060GSD6 [ARUV060GSD6]

Category	Functions	Multi V S
Reliability	Defrost / Deicing	X
	High pressure switch	X
	Phase protection	X
	Restart delay (3-minutes)	O
	Self diagnosis	O
	Soft start	O
	Test Run function	X
Convenience	Night Silent Operation	O
CAC network function	Network solution(LGAP)	O

Note

■ O : Applied, X : Not applied

- Accessory : Ordered and purchased separately the accessory package referring to the model name provided and install at field.

- Accessory line-ups varies by region, so check your local catalogue or local sales material.

3. Accessory Compatibility List

ARUV030GSD6 [ARUV030GSD6], ARUV040GSD6 [ARUV040GSD6], ARUV050GSD6 [ARUV050GSD6], ARUV060GSD6 [ARUV060GSD6]

Device		Accessory Model Name
Central Controller	AC Ez (Simple Controller)	PQCSZ250S0
	AC Ez Touch	PACEZA000
	AC Smart IV	PACS4B000
	AC Smart 5	PACS5A000
	ACP(Advanced Control Platform) IV	PACP4B000
	ACP(Advanced Control Platform) 5	PACP5A000
	AC Manager 5	PACM5A000
	ACS IO Module	X
	DO(Digital Output) Kit	X
BNU	ACP Lonworks	PLNWKB000
(Building Network Unit)	ACP BACnet	PQNFB17C0
Gateway	Cloud Gateway	PWFMDB200
Installation	Refrigerant Charging Kit	O (Logical operation)
PDI	Standard	PPWRDB000
(Power Distribution Indicator)	Premium	PQNUD1S40
Cool / Heat Selector		X
Low Ambient Kit		X
IO Module (ODU Dry Contact)		X
Cycle Monitoring Device	LGMV	PRCTIL0
	Mobile LGMV	PLGMVW100
DS(Data Saving) Module		PVADTN000

Note :

O : Applied, X : Not applied

Accessory model name : Installed at field, ordered and purchased separately by the corresponding model name, supplied with separate package.

4. Dimensions

4.1 Dimensional Drawing

ARUV030GSD6 [ARUV030GSD6]

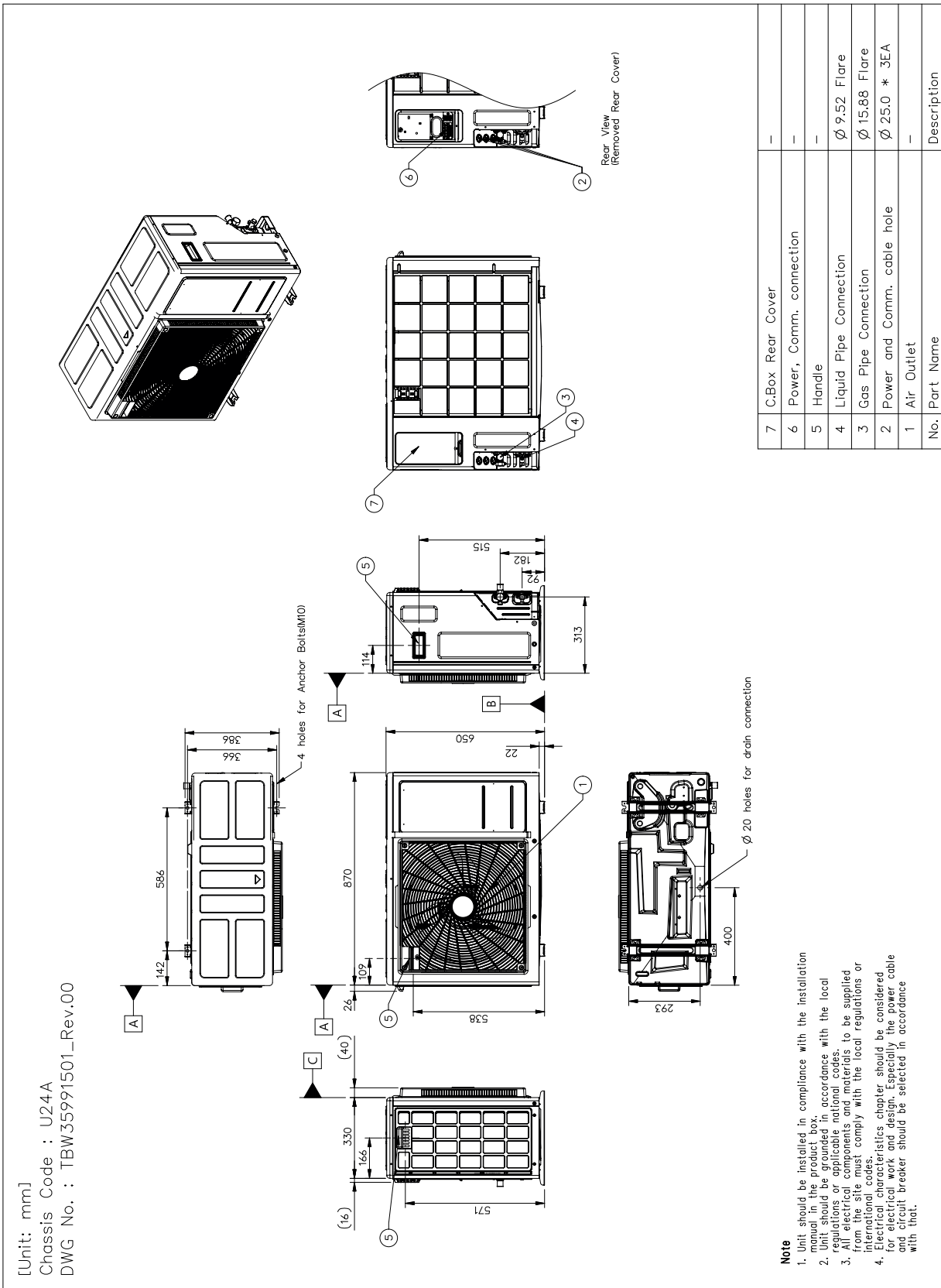

4. Dimensions

ARUV040GSD6 [ARUV040GSD6], ARUV050GSD6 [ARUV050GSD6], ARUV060GSD6 [ARUV060GSD6]

[Unit: mm]

Chassis : U36A

REV No. : TBW35991601_Rev.00

Note

- Unit should be installed in compliance with the installation manual in the product box.
- Unit should be grounded in accordance with the local regulations or applicable national codes.
- Wiring materials to be supplied from the site must comply with the local regulations or international codes.
- Electrical characteristics chapter should be considered for electrical work and design. Especially the power cable and circuit breaker should be selected in accordance with that.

No.	Part Name	Description
7	C/Box Rear Cover	-
6	Power, Comm. connection	-
5	Handle	-
4	Liquid Pipe Connection	Ø 9.52 Flare
3	Gas Pipe Connection	ØHP : Ø19.05 Flare 3, 4, SHP : Ø15.88 Flare
2	Power and Comm. cable hole	Ø 25.0 * 3EA
1	Air Outlet	-

4. Electric Characteristics

◆ Wiring of Main Power Supply and Equipment Capacity

1. Bear in mind ambient conditions (ambient temperature, direct sunlight, rain liquid, etc.) when proceeding with the wiring and connections.
2. The wire size is the minimum value for metal conduit wiring. The power cord size should be 1 rank thicker taking into account the line voltage drops. Make sure the power-supply voltage does not drop more than 10%.
3. Specific wiring requirements should adhere to the wiring regulations of the region.
4. Power supply cords of parts of appliances for outdoor use should not be lighter than polychloroprene sheathed flexible cord.
5. Don't install an individual switch or electrical outlet to disconnect each of indoor unit separately from the power supply.

WARNING

- Follow ordinance of your governmental organization for technical standard related to electrical equipment, wiring regulations and guidance of each electric power company.
- Make sure to use specified wires for connections so that no external force is imparted to terminal connections. If connections are not fixed firmly, it may cause heating or fire.
- Make sure to use the appropriate type of overcurrent protection switch. Note that generated overcurrent may include some amount of direct current.

CAUTION

- All Installation site must require attachment of an earth leakage breaker. If no earth leakage breaker is installed, it may cause an electric shock.
- Do not use anything other than breaker and fuse with correct capacity. Using fuse and wire or copper wire with too large capacity may cause a malfunction of unit or fire.

4. Electric Characteristics

◆ 50Hz

Model	Unit			Power Supply			COMP			OFM	
	Hz	Volts	Voltage-range	MCA	TOCA	MFA	MSC	RLA(Cooling)	RLA(Heating)	kW	FLA
ARUV030GSD6	50	220-240	Max. : 264 Min. : 198	18.0	19.8	20	-	13.2	-	0.085	0.4
ARUV040GSD6				19.3	21.3	30	-	15.9	-	0.124	0.5
ARUV050GSD6				24.5	27.0	30	-	20.9	-	0.124	0.5
ARUV060GSD6				28.4	31.3	40	-	25.1	-	0.124	0.5

◆ 60Hz

Model	Unit			Power Supply			COMP			OFM	
	Hz	Volts	Voltage-range	MCA	TOCA	MFA	MSC	RLA(Cooling)	RLA(Heating)	kW	FLA
ARUV030GSD6	60	220	Max. : 242 Min. : 198	18.0	19.8	20	-	13.2	-	0.085	0.4
ARUV040GSD6				19.3	21.3	30	-	15.9	-	0.124	0.5
ARUV050GSD6				24.5	27.0	30	-	20.9	-	0.124	0.5
ARUV060GSD6				28.4	31.3	40	-	25.1	-	0.124	0.5

Notes:

1. Voltage range
Voltage supplied to the unit terminals should be within the minimum and maximum range
2. Maximum allowable voltage unbalance between phase is 2%
3. OFM is measured as the outdoor unit test condition.
4. Select wire spec. based on the larger value of MCA or TOCA.
5. TOCA means the total over current value of each outdoor unit.
6. MSC means the Max. current during the starting of compressor.
7. All installation site must require attachment of an earth leakage breaker. [circuit breaker type is ELCB(Earth Leakage Circuit Breaker)]

8. MFA is used to select the circuit breaker and ground fault circuit interrupter (earth leakage circuit breaker)

<p>MCA : Minimum Circuit Amperes (A) MSC : Maximum Starting Current RLA : Rated Load Amperes (A) OFM : Outdoor Fan Motor kW : Fan Motor rated output (kW) FLA : Full Load Amperes (A) MFA: Maximum Fuse Amperes(A) TOCA: Total Over Current Amperes(A)</p>

5. Indoor Unit and Outdoor Unit Capacity Index

5.1 Outdoor Unit Selection

See the indoor unit capacity tables for given Indoor and Outdoor temperature.
Select the unit whose capacity is the nearest to or greater than given load.

Note:

Individual Indoor Unit capacity is subject to change by combination. Actual capacity has to be calculated according to the combination by using Outdoor unit capacity table.

5.2 Outdoor Unit Selection

Allowable combinations are indicated below. In general, outdoor unit can be selected depending on the location of the unit, zoning and usage of the rooms.

The indoor and outdoor unit combination is determined by comparing the sum of indoor unit capacity index with each Outdoor Unit. It is recommended to be the nearest to 100% combination ratio or to be smaller than that. Refer the table below. To manage cooling/heating load properly, it's better to be selected the bigger capacity outdoor unit rather than the nearest, if the installation space is large enough.

Allowable Total Capacity Index Table of Combined Indoor Units

Outdoor Unit Capacity(HP)	Indoor Unit Combination Ratio								
	50%	60%	70%	80%	90%	100%	110%	120%	130%
3	4.1	4.9	5.7	6.6	7.4	8.2	9.0	9.8	10.7
4	5.5	6.6	7.7	8.8	9.9	11.0	12.1	13.2	14.3
5	7.3	8.7	10.2	11.6	13.1	14.5	16.0	17.4	18.9
6	8.0	9.6	11.2	12.8	14.4	16.0	17.6	19.2	20.8

* Capacity Index is same as the capacity(kW).

INDOOR UNIT CAPACITY INDEX

Unit Capacity (Btu/h)	5k	7k	9k	12k	15k	18k	21k	24k	28k	36k	42k	48k	54k
Capacity Index	1.6	2.2	2.8	3.6	4.5	5.6	6.2	7.1	8.2	10.6	12.3	14.1	15.8

* Capacity Index is same as the capacity(kW).

CAUTION

We can guarantee the operation only within 130% Combination Ratio.

5. Piping Diagrams

5.1 Cooling Operation

ARUV030GSD6 [ARUV030GSD6]

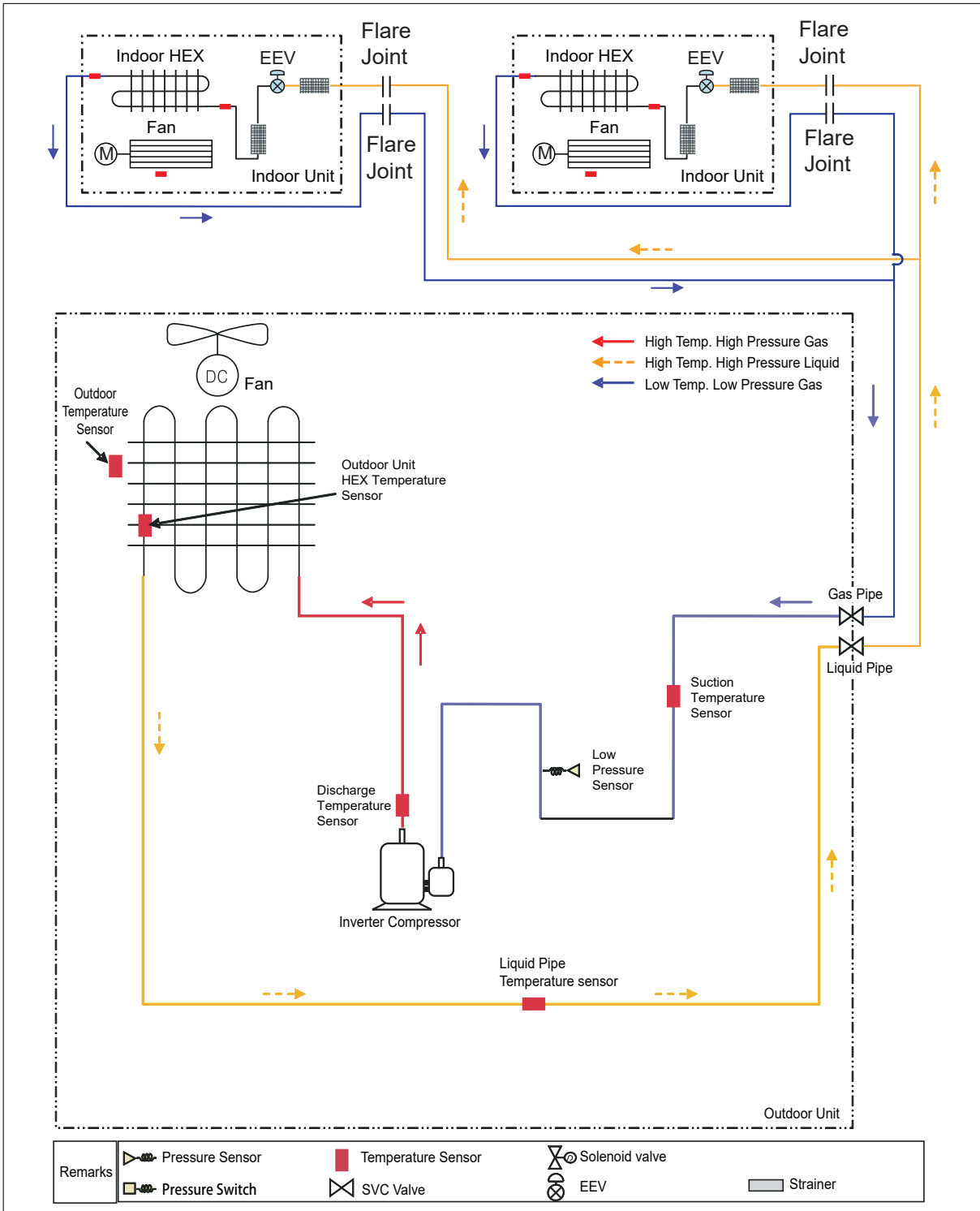

5. Piping Diagrams

5.1 Cooling Operation

ARUV040GSD6 [ARUV040GSD6], ARUV050GSD6[ARUV050GSD6],
ARUV060GSD6 [ARUV060GSD6]

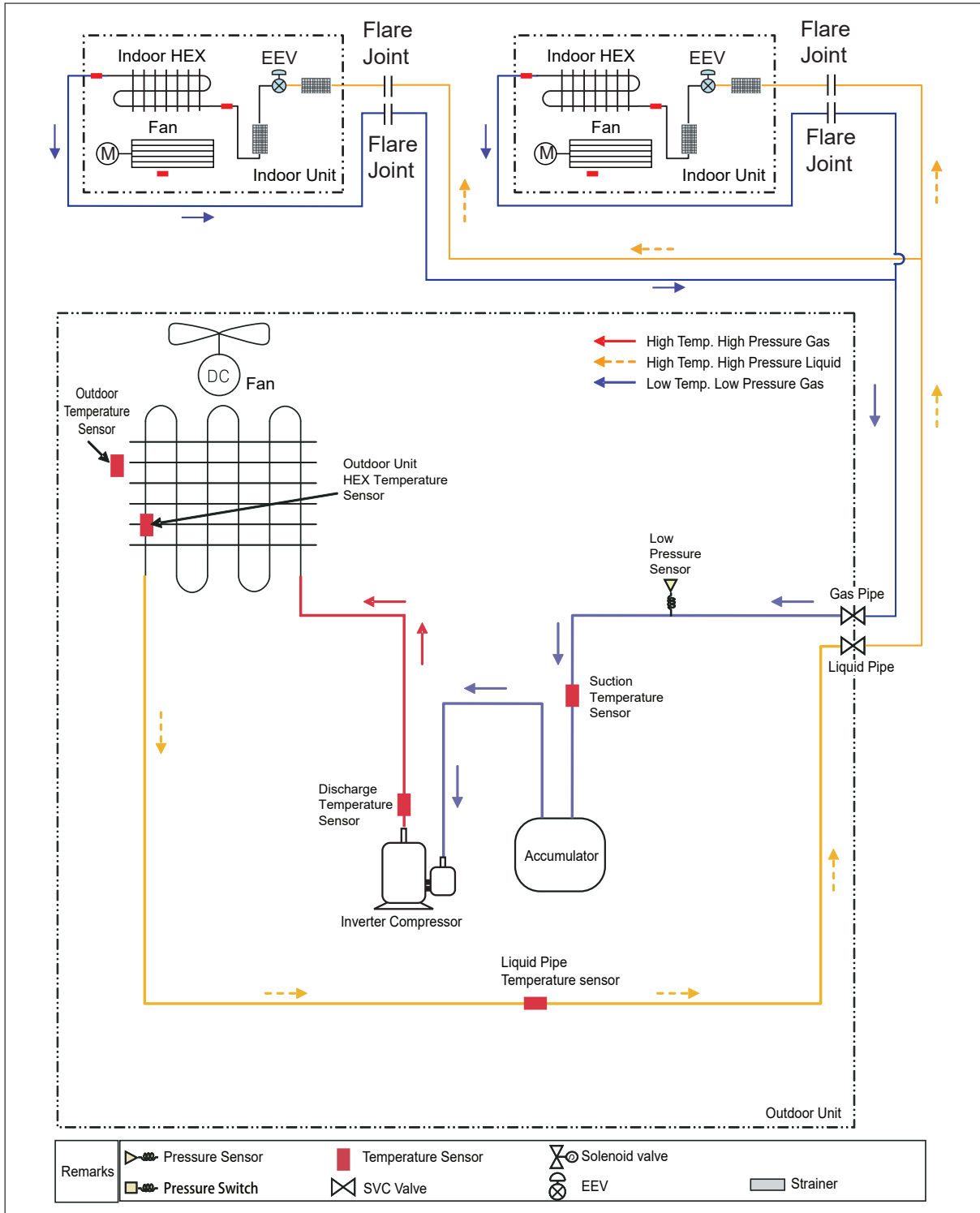

6. Wiring Diagrams

6.1 Product

ARUV030GSD6 [ARUV030GSD6]

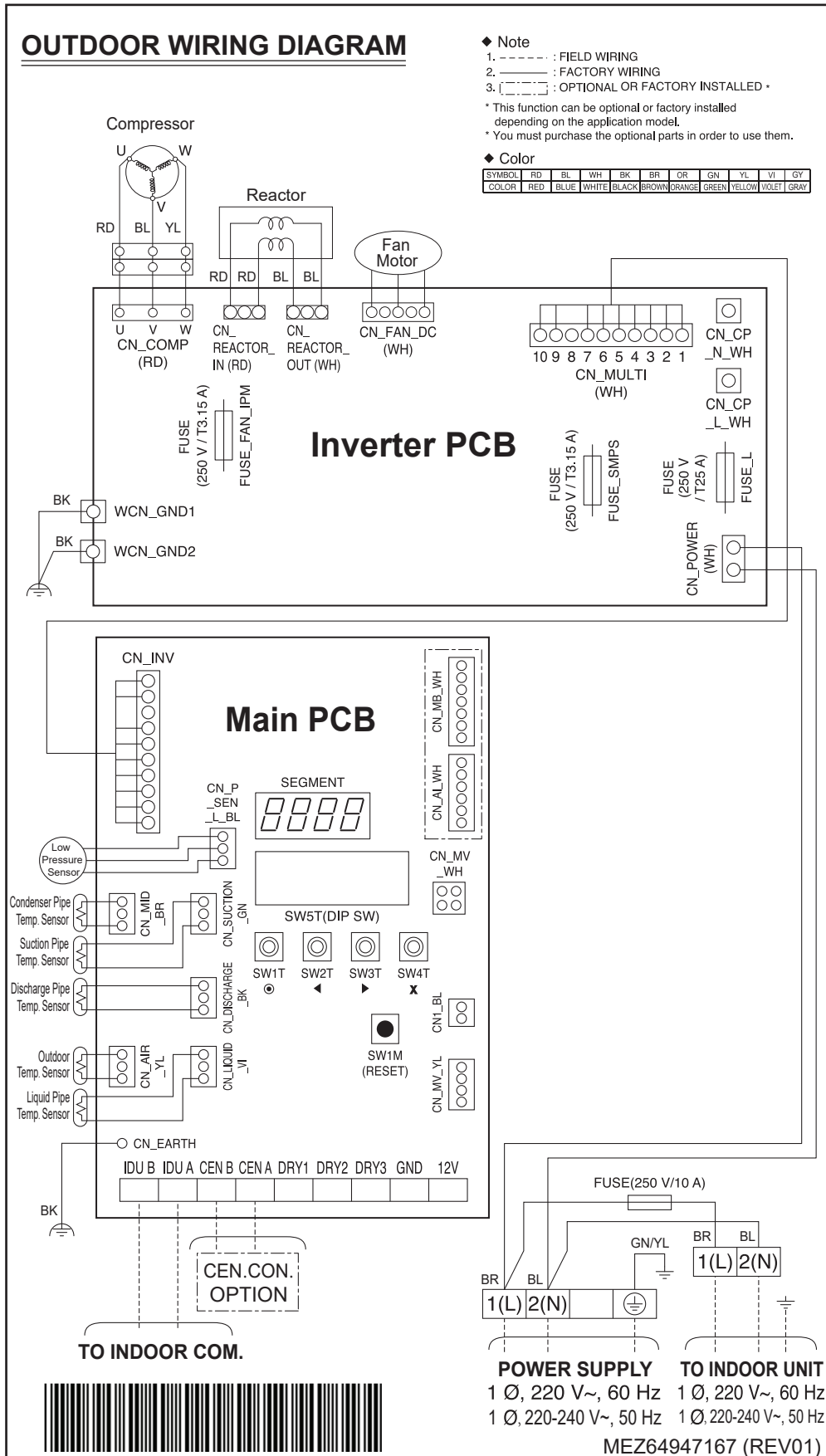

6. Wiring Diagrams

ARUV040GSD6 [ARUV040GSD6]

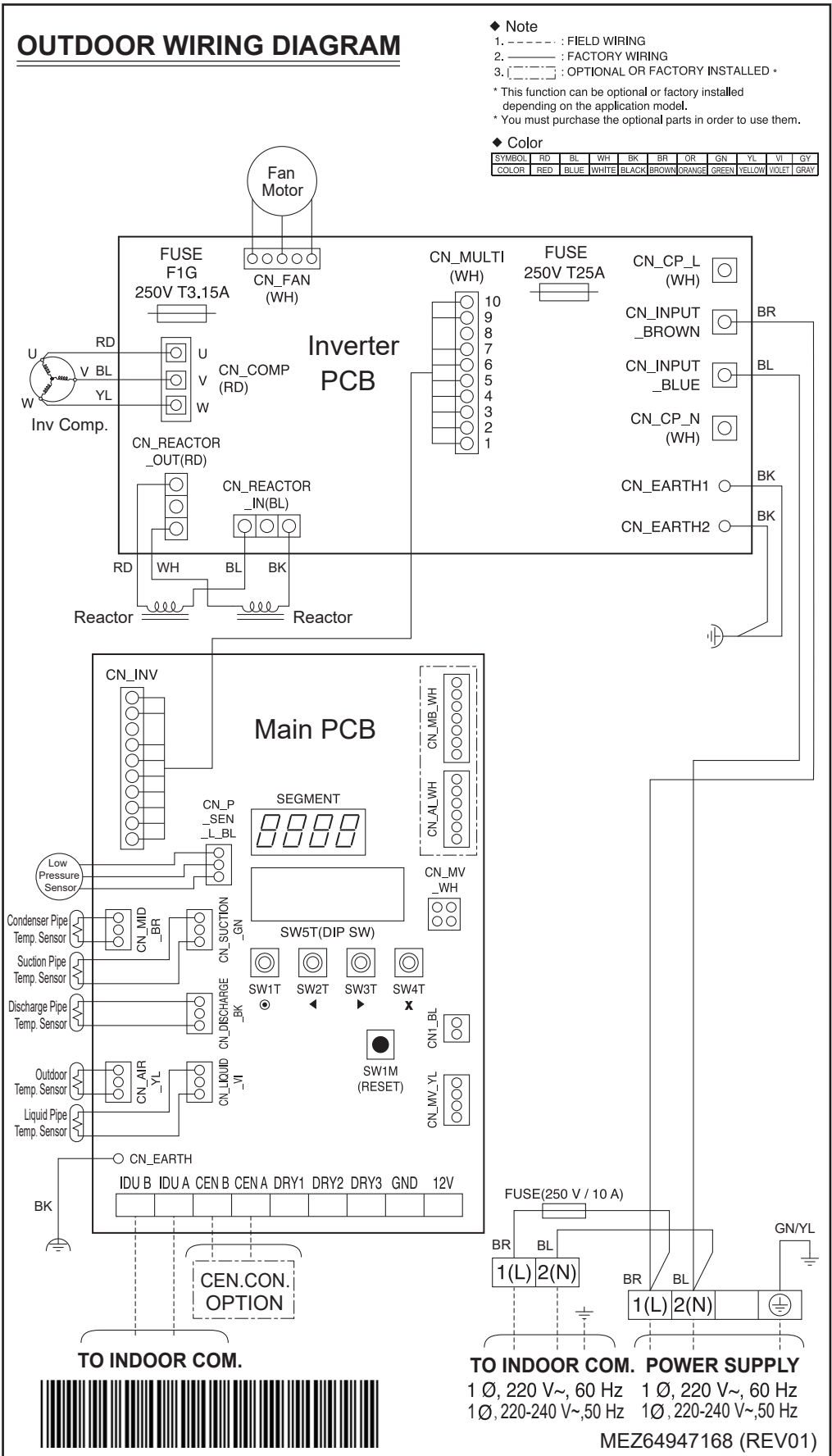

6. Wiring Diagrams

ARUV050GSD6 [ARUV050GSD6], ARUV060GSD6 [ARUV060GSD6]

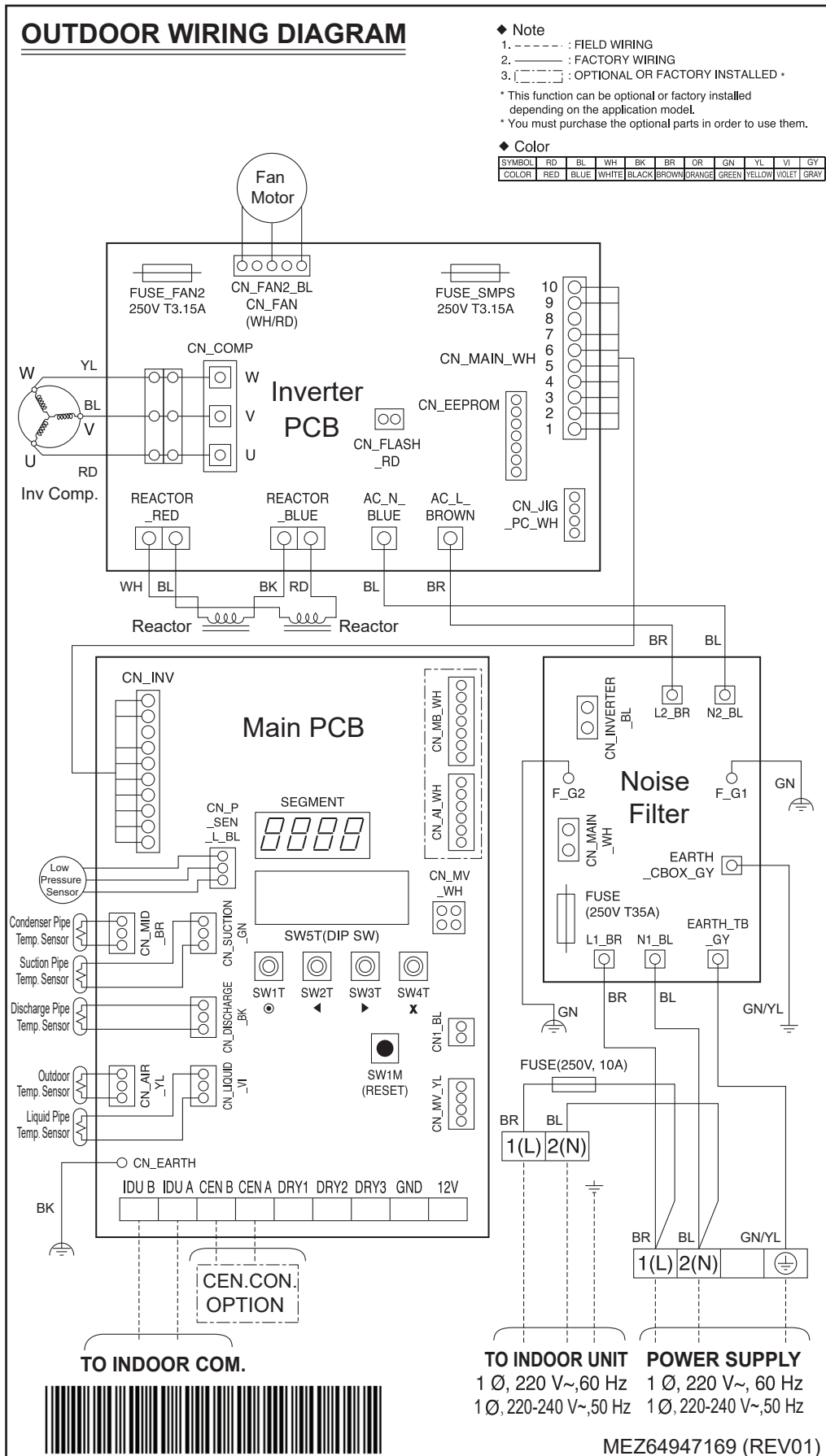

7. Capacity Tables

7.1 Cooling Operation (Standard)

ARUV030GSD6 [ARUV030GSD6]

Combination	Outdoor Air Temperature (°C DB)	Indoor Air Temperature (°C, DB/WB)													
		20.0 / 14.0		23.0 / 16.0		26.0 / 18.0		27.0 / 19.0		28.0 / 20.0		30.0 / 22.0		32.0 / 24.0	
		TC	PI	TC	PI	TC	PI	TC	PI	TC	PI	TC	PI	TC	PI
130	10	7.5	0.98	8.9	1.20	10.4	1.40	10.8	1.42	10.9	1.44	11.2	1.45	11.4	1.45
	12	7.5	1.01	8.9	1.25	10.4	1.45	10.6	1.46	10.8	1.49	11.0	1.51	11.3	1.51
	14	7.5	1.04	8.9	1.29	10.3	1.51	10.5	1.52	10.6	1.54	10.9	1.56	11.2	1.57
	16	7.5	1.08	8.9	1.34	10.2	1.57	10.3	1.59	10.5	1.60	10.7	1.62	11.0	1.63
	18	7.5	1.13	8.9	1.41	10.1	1.66	10.2	1.67	10.3	1.68	10.6	1.69	10.9	1.70
	20	7.5	1.18	8.9	1.51	9.9	1.74	10.1	1.75	10.2	1.77	10.5	1.77	10.7	1.78
	21	7.5	1.21	8.9	1.56	9.8	1.78	10.0	1.80	10.1	1.81	10.4	1.82	10.7	1.83
	23	7.5	1.29	8.9	1.67	9.7	1.85	9.8	1.87	10.0	1.89	10.2	1.90	10.5	1.91
	25	7.5	1.38	8.9	1.79	9.6	1.94	9.7	1.96	9.8	1.97	10.1	1.98	10.4	1.99
	27	7.5	1.48	8.9	1.91	9.4	2.02	9.6	2.04	9.7	2.05	10.0	2.06	10.2	2.07
	29	7.5	1.58	8.9	2.04	9.3	2.11	9.4	2.12	9.6	2.13	9.8	2.15	10.1	2.16
	31	7.5	1.68	8.9	2.15	9.1	2.19	9.3	2.20	9.4	2.22	9.7	2.23	10.0	2.24
	33	7.5	1.79	8.7	2.23	9.0	2.27	9.2	2.29	9.3	2.30	9.6	2.31	9.8	2.32
	35	7.5	1.91	8.6	2.32	8.9	2.36	9.0	2.37	9.2	2.38	9.4	2.39	9.7	2.41
	37	7.5	1.98	8.5	2.36	8.7	2.40	8.9	2.42	9.0	2.43	9.3	2.44	9.5	2.46
	39	7.5	2.05	8.3	2.41	8.6	2.45	8.7	2.47	8.9	2.48	9.1	2.48	9.4	2.50
	41	7.2	2.31	7.9	2.69	8.2	2.74	8.3	2.75	8.4	2.76	8.7	2.77	8.9	2.79
	43	7.1	2.45	7.6	2.81	7.9	2.86	8.0	2.88	8.2	2.89	8.4	2.90	8.7	2.92
46	6.7	2.61	7.0	2.94	7.2	3.00	7.3	3.01	7.5	3.02	7.7	3.03	7.9	3.05	
48	5.9	2.25	6.1	2.51	6.3	2.55	6.4	2.56	6.5	2.57	6.7	2.58	6.9	2.60	
120	10	6.9	0.89	8.2	1.09	9.6	1.29	10.3	1.39	10.7	1.42	11.0	1.42	11.2	1.43
	12	6.9	0.91	8.2	1.12	9.6	1.34	10.3	1.42	10.6	1.47	10.8	1.49	11.1	1.49
	14	6.9	0.94	8.2	1.16	9.6	1.40	10.3	1.48	10.4	1.52	10.7	1.54	11.0	1.56
	16	6.9	0.97	8.2	1.21	9.6	1.45	10.2	1.56	10.3	1.59	10.6	1.60	10.8	1.62
	18	6.9	1.01	8.2	1.26	9.6	1.54	10.0	1.64	10.2	1.67	10.4	1.68	10.7	1.69
	20	6.9	1.05	8.2	1.34	9.6	1.64	9.9	1.74	10.0	1.76	10.3	1.76	10.5	1.77
	21	6.9	1.08	8.2	1.39	9.6	1.70	9.8	1.78	10.0	1.80	10.2	1.80	10.5	1.81
	23	6.9	1.16	8.2	1.48	9.6	1.81	9.7	1.86	9.8	1.88	10.1	1.89	10.3	1.89
	25	6.9	1.24	8.2	1.59	9.4	1.91	9.6	1.94	9.7	1.96	10.0	1.97	10.2	1.98
	27	6.9	1.32	8.2	1.70	9.3	2.00	9.4	2.02	9.6	2.04	9.8	2.05	10.0	2.06
	29	6.9	1.41	8.2	1.81	9.2	2.09	9.3	2.10	9.4	2.12	9.6	2.13	9.9	2.14
	31	6.9	1.50	8.2	1.94	9.0	2.17	9.2	2.18	9.3	2.21	9.5	2.21	9.8	2.22
	33	6.9	1.60	8.2	2.06	8.9	2.25	9.0	2.27	9.1	2.29	9.4	2.30	9.6	2.31
	35	6.9	1.70	8.2	2.20	8.7	2.34	8.9	2.35	9.0	2.37	9.3	2.38	9.5	2.39
	37	6.9	1.77	8.2	2.26	8.6	2.38	8.7	2.40	8.9	2.41	9.1	2.42	9.3	2.43
	39	6.9	1.85	8.2	2.31	8.5	2.42	8.6	2.44	8.7	2.45	9.0	2.46	9.2	2.47
	41	6.7	2.11	7.8	2.59	8.0	2.70	8.2	2.72	8.3	2.72	8.5	2.74	8.8	2.75
	43	6.6	2.25	7.5	2.72	7.8	2.82	7.9	2.84	8.0	2.85	8.3	2.86	8.5	2.87
46	6.2	2.42	6.9	2.86	7.1	2.94	7.2	2.97	7.3	2.98	7.5	2.99	7.8	2.99	
48	5.5	2.09	6.0	2.44	6.2	2.50	6.3	2.52	6.4	2.53	6.6	2.54	6.8	2.55	
110	10	6.3	0.80	7.6	0.97	8.8	1.15	9.4	1.25	10.0	1.34	10.8	1.40	11.0	1.40
	12	6.3	0.82	7.6	1.00	8.8	1.20	9.4	1.28	10.0	1.39	10.6	1.45	10.9	1.47
	14	6.3	0.85	7.6	1.05	8.8	1.26	9.4	1.35	10.0	1.46	10.5	1.51	10.7	1.54
	16	6.3	0.88	7.6	1.09	8.8	1.31	9.4	1.41	10.0	1.55	10.4	1.59	10.6	1.60
	18	6.3	0.91	7.6	1.13	8.8	1.38	9.4	1.50	10.0	1.64	10.2	1.67	10.5	1.68
	20	6.3	0.94	7.6	1.19	8.8	1.47	9.4	1.60	9.9	1.73	10.1	1.75	10.3	1.76
	21	6.3	0.96	7.6	1.22	8.8	1.52	9.4	1.65	9.8	1.77	10.0	1.79	10.2	1.80
	23	6.3	1.03	7.6	1.31	8.8	1.63	9.4	1.75	9.6	1.86	9.9	1.87	10.1	1.88

7. Capacity Tables

Combination	Outdoor Air Temperature (°C DB)	Indoor Air Temperature (°C, DB/WB)													
		20.0 / 14.0		23.0 / 16.0		26.0 / 18.0		27.0 / 19.0		28.0 / 20.0		30.0 / 22.0		32.0 / 24.0	
		TC	PI	TC	PI	TC	PI	TC	PI	TC	PI	TC	PI	TC	PI
110	25	6.3	1.10	7.6	1.40	8.8	1.74	9.4	1.86	9.5	1.94	9.7	1.96	10.0	1.96
	27	6.3	1.17	7.6	1.50	8.8	1.87	9.2	1.96	9.4	2.03	9.6	2.04	9.8	2.05
	29	6.3	1.25	7.6	1.60	8.8	1.99	9.1	2.04	9.2	2.11	9.5	2.12	9.7	2.13
	31	6.3	1.33	7.6	1.70	8.8	2.13	9.0	2.14	9.1	2.19	9.3	2.20	9.5	2.21
	33	6.3	1.42	7.6	1.81	8.7	2.25	8.8	2.23	9.0	2.27	9.2	2.28	9.4	2.29
	35	6.3	1.51	7.6	1.94	8.6	2.32	8.7	2.33	8.8	2.35	9.0	2.36	9.3	2.37
	37	6.3	1.56	7.6	2.00	8.4	2.37	8.6	2.37	8.7	2.39	8.9	2.40	9.1	2.41
	39	6.3	1.62	7.6	2.05	8.3	2.40	8.4	2.41	8.5	2.43	8.8	2.44	9.0	2.45
	41	6.1	1.84	7.3	2.31	7.9	2.67	8.0	2.68	8.1	2.70	8.3	2.71	8.5	2.72
	43	6.0	1.96	7.2	2.44	7.6	2.79	7.7	2.79	7.8	2.81	8.1	2.83	8.3	2.84
	46	5.6	2.10	6.7	2.59	6.9	2.90	7.1	2.91	7.2	2.93	7.4	2.94	7.6	2.95
48	5.0	1.82	5.9	2.22	6.0	2.46	6.1	2.47	6.2	2.49	6.4	2.49	6.6	2.50	
100	10	5.5	0.72	6.6	0.87	7.7	1.03	8.2	1.12	8.7	1.20	9.8	1.34	10.8	1.35
	12	5.5	0.74	6.6	0.91	7.7	1.07	8.2	1.15	8.7	1.24	9.8	1.41	10.6	1.42
	14	5.5	0.76	6.6	0.94	7.7	1.11	8.2	1.20	8.7	1.29	9.8	1.49	10.5	1.50
	16	5.5	0.79	6.6	0.97	7.7	1.16	8.2	1.25	8.7	1.36	9.8	1.56	10.4	1.58
	18	5.5	0.81	6.6	1.01	7.7	1.21	8.2	1.32	8.7	1.44	9.8	1.65	10.2	1.66
	20	5.5	0.84	6.6	1.05	7.7	1.28	8.2	1.41	8.7	1.55	9.8	1.73	10.1	1.74
	21	5.5	0.86	6.6	1.07	7.7	1.32	8.2	1.46	8.7	1.60	9.8	1.77	10.0	1.78
	23	5.5	0.91	6.6	1.15	7.7	1.42	8.2	1.56	8.7	1.72	9.7	1.85	9.9	1.86
	25	5.5	0.96	6.6	1.22	7.7	1.51	8.2	1.67	8.7	1.84	9.5	1.93	9.7	1.94
	27	5.5	1.03	6.6	1.31	7.7	1.62	8.2	1.79	8.7	1.95	9.4	2.02	9.6	2.03
	29	5.5	1.10	6.6	1.40	7.7	1.73	8.2	1.91	8.7	2.07	9.3	2.10	9.5	2.12
	31	5.5	1.17	6.6	1.49	7.7	1.84	8.2	2.04	8.7	2.17	9.1	2.18	9.3	2.20
	33	5.5	1.24	6.6	1.58	7.7	1.97	8.2	2.17	8.7	2.25	9.0	2.26	9.2	2.28
	35	5.5	1.32	6.6	1.69	7.7	2.10	8.2	2.32	8.6	2.33	8.8	2.34	9.0	2.36
	37	5.5	1.37	6.6	1.76	7.7	2.16	8.2	2.36	8.5	2.37	8.7	2.38	8.9	2.40
	39	5.5	1.43	6.6	1.83	7.7	2.21	8.2	2.40	8.3	2.41	8.6	2.42	8.8	2.44
	41	5.3	1.62	6.4	2.08	7.4	2.48	7.8	2.67	7.9	2.68	7.9	2.69	8.3	2.71
43	5.3	1.72	6.3	2.21	7.3	2.62	7.5	2.78	7.6	2.79	7.9	2.80	8.1	2.83	
46	4.9	1.84	5.9	2.37	6.8	2.76	6.9	2.90	7.0	2.91	7.2	2.92	7.4	2.94	
48	4.4	1.59	5.2	2.05	5.9	2.36	6.0	2.46	6.0	2.47	6.2	2.47	6.4	2.49	
90	10	5.0	0.72	5.9	0.87	6.9	1.03	7.4	1.12	7.8	1.20	8.8	1.34	9.8	1.35
	12	5.0	0.74	5.9	0.91	6.9	1.07	7.4	1.15	7.8	1.24	8.8	1.41	9.8	1.42
	14	5.0	0.76	5.9	0.94	6.9	1.11	7.4	1.20	7.8	1.29	8.8	1.49	9.8	1.50
	16	5.0	0.79	5.9	0.97	6.9	1.16	7.4	1.25	7.8	1.36	8.8	1.56	9.8	1.58
	18	5.0	0.81	5.9	1.01	6.9	1.21	7.4	1.32	7.8	1.44	8.8	1.65	9.8	1.66
	20	5.0	0.84	5.9	1.05	6.9	1.28	7.4	1.41	7.8	1.55	8.8	1.73	9.8	1.74
	21	5.0	0.86	5.9	1.07	6.9	1.32	7.4	1.46	7.8	1.60	8.8	1.77	9.8	1.78
	23	5.0	0.91	5.9	1.15	6.9	1.42	7.4	1.56	7.8	1.72	8.8	1.85	9.6	1.86
	25	5.0	0.96	5.9	1.22	6.9	1.51	7.4	1.67	7.8	1.84	8.8	1.93	9.5	1.94
	27	5.0	1.03	5.9	1.31	6.9	1.62	7.4	1.79	7.8	1.95	8.8	2.02	9.4	2.03
	29	5.0	1.10	5.9	1.40	6.9	1.73	7.4	1.91	7.8	2.07	8.8	2.10	9.2	2.12
	31	5.0	1.17	5.9	1.49	6.9	1.84	7.4	2.04	7.8	2.17	8.8	2.18	9.1	2.20
	33	5.0	1.24	5.9	1.58	6.9	1.97	7.4	2.17	7.8	2.25	8.8	2.26	9.0	2.28
	35	5.0	1.32	5.9	1.69	6.9	2.10	7.4	2.32	7.8	2.33	8.7	2.34	8.8	2.36
	37	5.0	1.37	5.9	1.76	6.9	2.16	7.4	2.36	7.8	2.37	8.5	2.38	8.7	2.40
	39	5.0	1.43	5.9	1.83	6.9	2.21	7.4	2.40	7.8	2.41	8.4	2.42	8.5	2.44
	41	4.8	1.62	5.7	2.08	6.7	2.48	7.1	2.67	7.6	2.68	8.0	2.69	8.1	2.71
43	4.7	1.72	5.6	2.21	6.6	2.62	7.0	2.78	7.5	2.79	7.7	2.80	7.8	2.83	
46	4.4	1.84	5.3	2.37	6.2	2.76	6.6	2.90	6.8	2.91	7.0	2.92	7.2	2.94	
48	3.9	1.59	4.7	2.05	5.4	2.36	5.8	2.46	5.9	2.47	6.1	2.47	6.2	2.49	

7. Capacity Tables

Combination	Outdoor Air Temperature (°C DB)	Indoor Air Temperature (°C, DB/WB)													
		20.0 / 14.0		23.0 / 16.0		26.0 / 18.0		27.0 / 19.0		28.0 / 20.0		30.0 / 22.0		32.0 / 24.0	
		TC	PI	TC	PI	TC	PI	TC	PI	TC	PI	TC	PI	TC	PI
80	10	4.4	0.72	5.3	0.87	6.1	1.03	6.6	1.12	7.0	1.20	7.8	1.34	8.7	1.35
	12	4.4	0.74	5.3	0.91	6.1	1.07	6.6	1.15	7.0	1.24	7.8	1.41	8.7	1.42
	14	4.4	0.76	5.3	0.94	6.1	1.11	6.6	1.20	7.0	1.29	7.8	1.49	8.7	1.50
	16	4.4	0.79	5.3	0.97	6.1	1.16	6.6	1.25	7.0	1.36	7.8	1.56	8.7	1.58
	18	4.4	0.81	5.3	1.01	6.1	1.21	6.6	1.32	7.0	1.44	7.8	1.65	8.7	1.66
	20	4.4	0.84	5.3	1.05	6.1	1.28	6.6	1.41	7.0	1.55	7.8	1.73	8.7	1.74
	21	4.4	0.86	5.3	1.07	6.1	1.32	6.6	1.46	7.0	1.60	7.8	1.77	8.7	1.78
	23	4.4	0.91	5.3	1.15	6.1	1.42	6.6	1.56	7.0	1.72	7.8	1.85	8.7	1.86
	25	4.4	0.96	5.3	1.22	6.1	1.51	6.6	1.67	7.0	1.84	7.8	1.93	8.7	1.94
	27	4.4	1.03	5.3	1.31	6.1	1.62	6.6	1.79	7.0	1.95	7.8	2.02	8.7	2.03
	29	4.4	1.10	5.3	1.40	6.1	1.73	6.6	1.91	7.0	2.07	7.8	2.10	8.7	2.12
	31	4.4	1.17	5.3	1.49	6.1	1.84	6.6	2.04	7.0	2.17	7.8	2.18	8.7	2.20
	33	4.4	1.24	5.3	1.58	6.1	1.97	6.6	2.17	7.0	2.25	7.8	2.26	8.7	2.28
	35	4.4	1.32	5.3	1.69	6.1	2.10	6.6	2.32	7.0	2.33	7.8	2.34	8.6	2.36
	37	4.4	1.37	5.3	1.76	6.1	2.16	6.6	2.36	7.0	2.37	7.8	2.38	8.5	2.40
	39	4.4	1.43	5.3	1.83	6.1	2.21	6.6	2.40	7.0	2.41	7.8	2.42	8.3	2.44
	41	4.3	1.62	5.1	2.08	5.9	2.48	6.3	2.67	6.8	2.68	7.6	2.69	7.9	2.71
43	4.2	1.72	5.0	2.21	5.8	2.62	6.2	2.78	6.7	2.79	7.5	2.80	7.6	2.83	
46	3.9	1.84	4.7	2.37	5.5	2.76	5.8	2.90	6.2	2.91	6.8	2.92	7.0	2.94	
48	3.5	1.59	4.2	2.05	4.8	2.36	5.2	2.46	5.5	2.47	5.9	2.47	6.1	2.49	
70	10	3.9	0.72	4.6	0.87	5.4	1.03	5.7	1.12	6.1	1.20	6.9	1.34	7.6	1.35
	12	3.9	0.74	4.6	0.91	5.4	1.07	5.7	1.15	6.1	1.24	6.9	1.41	7.6	1.42
	14	3.9	0.76	4.6	0.94	5.4	1.11	5.7	1.20	6.1	1.29	6.9	1.49	7.6	1.50
	16	3.9	0.79	4.6	0.97	5.4	1.16	5.7	1.25	6.1	1.36	6.9	1.56	7.6	1.58
	18	3.9	0.81	4.6	1.01	5.4	1.21	5.7	1.32	6.1	1.43	6.9	1.63	7.6	1.66
	20	3.9	0.84	4.6	1.05	5.4	1.26	5.7	1.36	6.1	1.46	6.9	1.67	7.6	1.74
	21	3.9	0.86	4.6	1.07	5.4	1.28	5.7	1.38	6.1	1.47	6.9	1.69	7.6	1.78
	23	3.9	0.91	4.6	1.11	5.4	1.30	5.7	1.42	6.1	1.55	6.9	1.81	7.6	1.86
	25	3.9	0.94	4.6	1.15	5.4	1.39	5.7	1.52	6.1	1.65	6.9	1.93	7.6	1.94
	27	3.9	0.99	4.6	1.23	5.4	1.48	5.7	1.61	6.1	1.76	6.9	2.02	7.6	2.03
	29	3.9	1.06	4.6	1.30	5.4	1.57	5.7	1.72	6.1	1.88	6.9	2.10	7.6	2.12
	31	3.9	1.13	4.6	1.39	5.4	1.68	5.7	1.84	6.1	2.00	6.9	2.18	7.6	2.20
	33	3.9	1.19	4.6	1.47	5.4	1.78	5.7	1.95	6.1	2.13	6.9	2.26	7.6	2.28
	35	3.9	1.26	4.6	1.57	5.4	1.90	5.7	2.07	6.1	2.26	6.9	2.34	7.6	2.36
	37	3.9	1.34	4.6	1.66	5.4	2.01	5.7	2.20	6.1	2.37	6.9	2.38	7.6	2.40
	39	3.9	1.40	4.6	1.75	5.4	2.13	5.7	2.33	6.1	2.41	6.9	2.42	7.6	2.44
	41	3.7	1.62	4.5	2.02	5.2	2.46	5.5	2.67	5.9	2.68	6.6	2.69	7.3	2.71
43	3.7	1.72	4.4	2.18	5.1	2.62	5.5	2.78	5.8	2.79	6.5	2.80	7.2	2.83	
46	3.4	1.84	4.1	2.37	4.8	2.76	5.1	2.90	5.5	2.91	6.1	2.92	6.8	2.94	
48	3.0	1.59	3.6	2.05	4.2	2.36	4.5	2.46	4.8	2.47	5.4	2.47	6.0	2.49	
60	10	3.3	0.68	4.0	0.80	4.6	0.93	4.9	1.00	5.2	1.06	5.9	1.21	6.5	1.35
	12	3.3	0.70	4.0	0.82	4.6	0.95	4.9	1.01	5.2	1.08	5.9	1.23	6.5	1.38
	14	3.3	0.70	4.0	0.83	4.6	0.96	4.9	1.03	5.2	1.10	5.9	1.25	6.5	1.40
	16	3.3	0.72	4.0	0.85	4.6	0.98	4.9	1.05	5.2	1.13	5.9	1.28	6.5	1.43
	18	3.3	0.73	4.0	0.86	4.6	1.00	4.9	1.07	5.2	1.15	5.9	1.29	6.5	1.46
	20	3.3	0.74	4.0	0.87	4.6	1.01	4.9	1.09	5.2	1.16	5.9	1.32	6.5	1.49
	21	3.3	0.75	4.0	0.88	4.6	1.03	4.9	1.10	5.2	1.18	5.9	1.34	6.5	1.50
	23	3.3	0.76	4.0	0.90	4.6	1.04	4.9	1.12	5.2	1.20	5.9	1.39	6.5	1.59
	25	3.3	0.77	4.0	0.91	4.6	1.08	4.9	1.18	5.2	1.28	5.9	1.48	6.5	1.71
	27	3.3	0.80	4.0	0.96	4.6	1.15	4.9	1.25	5.2	1.36	5.9	1.57	6.5	1.82
	29	3.3	0.85	4.0	1.03	4.6	1.23	4.9	1.33	5.2	1.44	5.9	1.68	6.5	1.94

7. Capacity Tables

Combination	Outdoor Air Temperature (°C DB)	Indoor Air Temperature (°C, DB/WB)													
		20.0 / 14.0		23.0 / 16.0		26.0 / 18.0		27.0 / 19.0		28.0 / 20.0		30.0 / 22.0		32.0 / 24.0	
		TC	PI	TC	PI	TC	PI	TC	PI	TC	PI	TC	PI	TC	PI
60	31	3.3	0.90	4.0	1.09	4.6	1.30	4.9	1.42	5.2	1.54	5.9	1.79	6.5	2.07
	33	3.3	0.95	4.0	1.15	4.6	1.38	4.9	1.51	5.2	1.64	5.9	1.90	6.5	2.20
	35	3.3	1.00	4.0	1.23	4.6	1.47	4.9	1.60	5.2	1.74	5.9	2.03	6.5	2.34
	37	3.3	1.06	4.0	1.29	4.6	1.56	4.9	1.70	5.2	1.84	5.9	2.15	6.5	2.40
	39	3.3	1.11	4.0	1.36	4.6	1.65	4.9	1.80	5.2	1.94	5.9	2.29	6.5	2.44
	41	3.2	1.27	3.8	1.57	4.4	1.90	4.7	2.07	5.1	2.24	5.7	2.64	6.3	2.71
	43	3.1	1.37	3.8	1.69	4.4	2.05	4.7	2.24	5.0	2.42	5.6	2.80	6.2	2.83
	46	2.9	1.49	3.5	1.84	4.1	2.24	4.4	2.44	4.7	2.64	5.2	2.92	5.8	2.94
48	2.6	1.29	3.1	1.61	3.6	1.95	3.9	2.13	4.1	2.31	4.6	2.47	5.1	2.49	
50	10	2.8	0.56	3.3	0.65	3.8	0.73	4.1	0.79	4.4	0.83	4.9	0.94	5.4	1.04
	12	2.8	0.56	3.3	0.65	3.8	0.74	4.1	0.80	4.4	0.85	4.9	0.96	5.4	1.06
	14	2.8	0.57	3.3	0.66	3.8	0.76	4.1	0.81	4.4	0.86	4.9	0.97	5.4	1.08
	16	2.8	0.58	3.3	0.67	3.8	0.77	4.1	0.83	4.4	0.87	4.9	0.99	5.4	1.10
	18	2.8	0.59	3.3	0.68	3.8	0.78	4.1	0.84	4.4	0.89	4.9	1.00	5.4	1.12
	20	2.8	0.59	3.3	0.69	3.8	0.80	4.1	0.85	4.4	0.91	4.9	1.02	5.4	1.14
	21	2.8	0.60	3.3	0.70	3.8	0.80	4.1	0.86	4.4	0.92	4.9	1.03	5.4	1.16
	23	2.8	0.61	3.3	0.71	3.8	0.82	4.1	0.87	4.4	0.93	4.9	1.05	5.4	1.18
	25	2.8	0.62	3.3	0.72	3.8	0.83	4.1	0.89	4.4	0.96	4.9	1.10	5.4	1.26
	27	2.8	0.63	3.3	0.74	3.8	0.88	4.1	0.95	4.4	1.02	4.9	1.18	5.4	1.34
	29	2.8	0.66	3.3	0.79	3.8	0.93	4.1	1.01	4.4	1.09	4.9	1.25	5.4	1.43
	31	2.8	0.70	3.3	0.84	3.8	0.99	4.1	1.07	4.4	1.16	4.9	1.33	5.4	1.52
	33	2.8	0.74	3.3	0.89	3.8	1.05	4.1	1.13	4.4	1.23	4.9	1.41	5.4	1.62
	35	2.8	0.78	3.3	0.94	3.8	1.11	4.1	1.20	4.4	1.30	4.9	1.50	5.4	1.72
	37	2.8	0.83	3.3	0.99	3.8	1.17	4.1	1.27	4.4	1.37	4.9	1.60	5.4	1.82
	39	2.8	0.86	3.3	1.04	3.8	1.24	4.1	1.34	4.4	1.44	4.9	1.68	5.4	1.93
	41	2.7	0.99	3.2	1.20	3.7	1.43	4.0	1.55	4.2	1.66	4.7	1.94	5.3	2.23
	43	2.6	1.07	3.1	1.29	3.6	1.54	3.9	1.67	4.1	1.79	4.6	2.09	5.2	2.41
46	2.5	1.16	2.9	1.40	3.4	1.68	3.7	1.81	3.9	1.95	4.4	2.29	4.9	2.63	
48	2.2	1.01	2.6	1.22	3.0	1.46	3.2	1.58	3.4	1.70	3.9	2.00	4.3	2.30	

Note

- TC: Total Capacity(kW), PI : Power Input(kW, Comp. + Outdoor fan motor)
- Capacity tables show the average value of conditions which may occur.

7. Capacity Tables

ARUV040GSD6 [ARUV040GSD6]

Combination	Outdoor Air Temperature (°C DB)	Indoor Air Temperature (°C, DB/WB)													
		20.0 / 14.0		23.0 / 16.0		26.0 / 18.0		27.0 / 19.0		28.0 / 20.0		30.0 / 22.0		32.0 / 24.0	
		TC	PI	TC	PI	TC	PI	TC	PI	TC	PI	TC	PI	TC	PI
130	10	10.1	1.17	12.0	1.43	13.9	1.66	14.4	1.69	14.6	1.71	15.0	1.72	15.3	1.73
	12	10.1	1.20	12.0	1.48	13.9	1.73	14.2	1.74	14.5	1.77	14.8	1.79	15.1	1.80
	14	10.1	1.24	12.0	1.54	13.9	1.79	14.1	1.81	14.2	1.84	14.6	1.85	15.0	1.87
	16	10.1	1.29	12.0	1.59	13.7	1.87	13.9	1.89	14.0	1.90	14.4	1.92	14.8	1.94
	18	10.1	1.34	12.0	1.68	13.5	1.97	13.7	1.99	13.9	2.00	14.2	2.01	14.6	2.02
	20	10.1	1.40	12.0	1.79	13.3	2.07	13.5	2.09	13.7	2.10	14.0	2.11	14.4	2.12
	21	10.1	1.43	12.0	1.85	13.2	2.12	13.4	2.14	13.6	2.15	13.9	2.16	14.3	2.17
	23	10.1	1.54	12.0	1.99	13.0	2.21	13.2	2.23	13.4	2.25	13.7	2.26	14.1	2.27
	25	10.1	1.64	12.0	2.13	12.8	2.31	13.0	2.33	13.2	2.34	13.6	2.36	13.9	2.37
	27	10.1	1.76	12.0	2.27	12.7	2.41	12.8	2.42	13.0	2.44	13.4	2.45	13.7	2.47
	29	10.1	1.87	12.0	2.43	12.5	2.50	12.7	2.52	12.8	2.54	13.2	2.55	13.6	2.57
	31	10.1	2.00	11.9	2.56	12.3	2.60	12.5	2.62	12.7	2.64	13.0	2.65	13.4	2.67
	33	10.1	2.13	11.7	2.66	12.1	2.70	12.3	2.72	12.5	2.73	12.8	2.75	13.2	2.76
	35	10.1	2.27	11.5	2.76	11.9	2.80	12.1	2.82	12.3	2.83	12.6	2.85	13.0	2.86
	37	10.1	2.35	11.4	2.81	11.7	2.86	11.9	2.88	12.1	2.89	12.4	2.90	12.8	2.92
	39	10.1	2.43	11.2	2.86	11.5	2.92	11.7	2.94	11.9	2.95	12.3	2.96	12.6	2.98
	41	9.7	2.75	10.6	3.20	10.9	3.25	11.1	3.28	11.3	3.29	11.7	3.30	12.0	3.32
	43	9.6	2.92	10.3	3.35	10.6	3.41	10.8	3.43	11.0	3.44	11.3	3.45	11.6	3.47
46	9.0	3.11	9.4	3.50	9.7	3.57	9.8	3.59	10.0	3.59	10.4	3.61	10.7	3.63	
48	7.9	2.67	8.1	2.99	8.4	3.04	8.6	3.05	8.7	3.05	9.0	3.07	9.3	3.09	
120	10	9.3	1.05	11.1	1.29	12.9	1.53	13.8	1.66	14.4	1.68	14.7	1.69	15.1	1.70
	12	9.3	1.08	11.1	1.34	12.9	1.60	13.8	1.69	14.2	1.75	14.5	1.77	14.9	1.78
	14	9.3	1.12	11.1	1.38	12.9	1.66	13.8	1.76	14.0	1.81	14.4	1.84	14.7	1.85
	16	9.3	1.16	11.1	1.44	12.9	1.73	13.7	1.85	13.8	1.90	14.2	1.90	14.5	1.92
	18	9.3	1.20	11.1	1.50	12.9	1.83	13.5	1.96	13.6	1.99	14.0	2.00	14.3	2.01
	20	9.3	1.25	11.1	1.59	12.9	1.95	13.3	2.07	13.5	2.09	13.8	2.10	14.1	2.11
	21	9.3	1.29	11.1	1.65	12.9	2.02	13.2	2.12	13.4	2.14	13.7	2.15	14.0	2.16
	23	9.3	1.38	11.1	1.76	12.9	2.15	13.0	2.21	13.2	2.24	13.5	2.24	13.8	2.25
	25	9.3	1.47	11.1	1.89	12.7	2.27	12.8	2.31	13.0	2.33	13.4	2.34	13.7	2.35
	27	9.3	1.57	11.1	2.02	12.5	2.39	12.7	2.40	12.8	2.43	13.2	2.44	13.5	2.45
	29	9.3	1.68	11.1	2.16	12.3	2.48	12.5	2.50	12.6	2.53	12.9	2.54	13.3	2.55
	31	9.3	1.79	11.1	2.30	12.1	2.59	12.3	2.60	12.5	2.62	12.8	2.63	13.1	2.64
	33	9.3	1.90	11.1	2.46	11.9	2.68	12.1	2.70	12.2	2.72	12.6	2.73	12.9	2.74
	35	9.3	2.02	11.1	2.62	11.7	2.79	11.9	2.80	12.1	2.82	12.4	2.83	12.7	2.84
	37	9.3	2.11	11.1	2.68	11.6	2.83	11.7	2.85	11.9	2.86	12.2	2.88	12.5	2.89
	39	9.3	2.20	11.0	2.75	11.3	2.88	11.5	2.90	11.7	2.91	12.0	2.93	12.4	2.94
	41	9.0	2.51	10.4	3.08	10.8	3.21	10.9	3.23	11.1	3.24	11.4	3.26	11.7	3.27
	43	8.8	2.68	10.1	3.23	10.4	3.35	10.6	3.38	10.8	3.39	11.1	3.41	11.4	3.42
46	8.3	2.88	9.2	3.40	9.5	3.50	9.7	3.53	9.8	3.54	10.1	3.55	10.4	3.56	
48	7.3	2.49	8.0	2.91	8.3	2.98	8.4	3.00	8.5	3.01	8.8	3.02	9.1	3.03	
110	10	8.5	0.95	10.1	1.15	11.8	1.37	12.6	1.48	13.4	1.60	14.4	1.66	14.8	1.67
	12	8.5	0.98	10.1	1.19	11.8	1.43	12.6	1.53	13.4	1.66	14.3	1.73	14.6	1.75
	14	8.5	1.01	10.1	1.25	11.8	1.49	12.6	1.60	13.4	1.74	14.1	1.79	14.4	1.83
	16	8.5	1.04	10.1	1.29	11.8	1.56	12.6	1.67	13.4	1.85	13.9	1.89	14.2	1.90
	18	8.5	1.08	10.1	1.35	11.8	1.64	12.6	1.78	13.4	1.96	13.7	1.99	14.0	2.00
	20	8.5	1.12	10.1	1.41	11.8	1.74	12.6	1.90	13.2	2.06	13.5	2.09	13.8	2.09
	21	8.5	1.15	10.1	1.46	11.8	1.81	12.6	1.97	13.1	2.11	13.4	2.13	13.7	2.14
23	8.5	1.22	10.1	1.56	11.8	1.94	12.6	2.09	12.9	2.21	13.3	2.23	13.5	2.24	

7. Capacity Tables

Combination	Outdoor Air Temperature (°C DB)	Indoor Air Temperature (°C, DB/WB)													
		20.0 / 14.0		23.0 / 16.0		26.0 / 18.0		27.0 / 19.0		28.0 / 20.0		30.0 / 22.0		32.0 / 24.0	
		TC	PI	TC	PI	TC	PI	TC	PI	TC	PI	TC	PI	TC	PI
110	25	8.5	1.30	10.1	1.67	11.8	2.07	12.6	2.21	12.8	2.30	13.1	2.33	13.4	2.34
	27	8.5	1.39	10.1	1.78	11.8	2.22	12.4	2.33	12.6	2.41	12.9	2.42	13.2	2.43
	29	8.5	1.49	10.1	1.90	11.8	2.37	12.2	2.43	12.4	2.51	12.7	2.52	13.0	2.53
	31	8.5	1.58	10.1	2.03	11.8	2.53	12.0	2.54	12.2	2.61	12.5	2.62	12.8	2.63
	33	8.5	1.69	10.1	2.16	11.7	2.67	11.9	2.65	12.0	2.70	12.3	2.72	12.6	2.73
	35	8.5	1.79	10.1	2.30	11.5	2.77	11.7	2.78	11.8	2.80	12.1	2.81	12.4	2.82
	37	8.5	1.86	10.1	2.37	11.3	2.81	11.5	2.82	11.6	2.84	11.9	2.86	12.2	2.87
	39	8.5	1.93	10.1	2.44	11.1	2.86	11.3	2.86	11.5	2.89	11.7	2.90	12.1	2.91
	41	8.2	2.19	9.8	2.75	10.5	3.18	10.7	3.19	10.9	3.21	11.2	3.23	11.4	3.24
	43	8.1	2.34	9.6	2.91	10.2	3.32	10.4	3.32	10.5	3.35	10.8	3.37	11.1	3.37
	46	7.6	2.50	9.0	3.08	9.3	3.45	9.5	3.46	9.6	3.48	9.9	3.50	10.1	3.51
48	6.7	2.16	7.9	2.64	8.1	2.92	8.2	2.94	8.3	2.96	8.6	2.97	8.8	2.98	
100	10	7.4	0.85	8.8	1.04	10.3	1.23	11.0	1.33	11.7	1.43	13.2	1.59	14.5	1.60
	12	7.4	0.88	8.8	1.08	10.3	1.27	11.0	1.37	11.7	1.47	13.2	1.68	14.3	1.69
	14	7.4	0.91	8.8	1.12	10.3	1.33	11.0	1.42	11.7	1.54	13.2	1.77	14.1	1.79
	16	7.4	0.94	8.8	1.16	10.3	1.38	11.0	1.49	11.7	1.62	13.2	1.85	13.9	1.88
	18	7.4	0.96	8.8	1.20	10.3	1.44	11.0	1.56	11.7	1.72	13.2	1.96	13.7	1.98
	20	7.4	1.00	8.8	1.25	10.3	1.52	11.0	1.68	11.7	1.84	13.2	2.05	13.5	2.07
	21	7.4	1.02	8.8	1.28	10.3	1.57	11.0	1.73	11.7	1.91	13.2	2.10	13.4	2.12
	23	7.4	1.08	8.8	1.37	10.3	1.69	11.0	1.86	11.7	2.04	13.0	2.20	13.3	2.22
	25	7.4	1.15	8.8	1.46	10.3	1.80	11.0	1.99	11.7	2.18	12.8	2.29	13.0	2.31
	27	7.4	1.23	8.8	1.56	10.3	1.93	11.0	2.13	11.7	2.32	12.6	2.40	12.9	2.42
	29	7.4	1.30	8.8	1.66	10.3	2.06	11.0	2.27	11.7	2.46	12.4	2.50	12.7	2.52
	31	7.4	1.39	8.8	1.77	10.3	2.19	11.0	2.42	11.7	2.58	12.2	2.59	12.5	2.61
	33	7.4	1.48	8.8	1.89	10.3	2.34	11.0	2.59	11.7	2.68	12.0	2.69	12.3	2.71
	35	7.4	1.57	8.8	2.01	10.3	2.49	11.0	2.76	11.5	2.78	11.9	2.79	12.1	2.81
	37	7.4	1.63	8.8	2.09	10.3	2.56	11.0	2.81	11.3	2.82	11.7	2.83	11.9	2.86
	39	7.4	1.70	8.8	2.17	10.3	2.63	11.0	2.85	11.1	2.87	11.5	2.88	11.7	2.90
	41	7.2	1.93	8.5	2.47	9.9	2.96	10.5	3.17	10.6	3.19	10.6	3.20	11.2	3.23
43	7.1	2.05	8.4	2.63	9.8	3.11	10.1	3.31	10.2	3.32	10.6	3.33	10.8	3.37	
46	6.6	2.19	7.9	2.82	9.2	3.29	9.2	3.45	9.3	3.46	9.6	3.47	9.9	3.50	
48	5.8	1.89	7.0	2.44	7.9	2.81	8.0	2.93	8.1	2.94	8.4	2.94	8.6	2.97	
90	10	6.7	0.85	8.0	1.04	9.3	1.23	9.9	1.33	10.5	1.43	11.8	1.59	13.1	1.60
	12	6.7	0.88	8.0	1.08	9.3	1.27	9.9	1.37	10.5	1.47	11.8	1.68	13.1	1.69
	14	6.7	0.91	8.0	1.12	9.3	1.33	9.9	1.42	10.5	1.54	11.8	1.77	13.1	1.79
	16	6.7	0.94	8.0	1.16	9.3	1.38	9.9	1.49	10.5	1.62	11.8	1.85	13.1	1.88
	18	6.7	0.96	8.0	1.20	9.3	1.44	9.9	1.56	10.5	1.72	11.8	1.96	13.1	1.98
	20	6.7	1.00	8.0	1.25	9.3	1.52	9.9	1.68	10.5	1.84	11.8	2.05	13.1	2.07
	21	6.7	1.02	8.0	1.28	9.3	1.57	9.9	1.73	10.5	1.91	11.8	2.10	13.1	2.12
	23	6.7	1.08	8.0	1.37	9.3	1.69	9.9	1.86	10.5	2.04	11.8	2.20	12.9	2.22
	25	6.7	1.15	8.0	1.46	9.3	1.80	9.9	1.99	10.5	2.18	11.8	2.29	12.8	2.31
	27	6.7	1.23	8.0	1.56	9.3	1.93	9.9	2.13	10.5	2.32	11.8	2.40	12.6	2.42
	29	6.7	1.30	8.0	1.66	9.3	2.06	9.9	2.27	10.5	2.46	11.8	2.50	12.4	2.52
	31	6.7	1.39	8.0	1.77	9.3	2.19	9.9	2.42	10.5	2.58	11.8	2.59	12.2	2.61
	33	6.7	1.48	8.0	1.89	9.3	2.34	9.9	2.59	10.5	2.68	11.8	2.69	12.0	2.71
	35	6.7	1.57	8.0	2.01	9.3	2.49	9.9	2.76	10.5	2.78	11.6	2.79	11.8	2.81
	37	6.7	1.63	8.0	2.09	9.3	2.56	9.9	2.81	10.5	2.82	11.4	2.83	11.6	2.86
	39	6.7	1.70	8.0	2.17	9.3	2.63	9.9	2.85	10.5	2.87	11.2	2.88	11.4	2.90
	41	6.4	1.93	7.7	2.47	8.9	2.96	9.6	3.17	10.2	3.19	10.7	3.20	10.9	3.23
43	6.3	2.05	7.6	2.63	8.8	3.11	9.4	3.31	10.0	3.32	10.3	3.33	10.5	3.37	
46	5.9	2.19	7.1	2.82	8.3	3.29	8.8	3.45	9.1	3.46	9.4	3.47	9.6	3.50	
48	5.3	1.89	6.3	2.44	7.3	2.81	7.8	2.93	7.9	2.94	8.2	2.94	8.4	2.97	

7. Capacity Tables

Combination	Outdoor Air Temperature (°C DB)	Indoor Air Temperature (°C, DB/WB)													
		20.0 / 14.0		23.0 / 16.0		26.0 / 18.0		27.0 / 19.0		28.0 / 20.0		30.0 / 22.0		32.0 / 24.0	
		TC	PI	TC	PI	TC	PI	TC	PI	TC	PI	TC	PI	TC	PI
80	10	5.9	0.85	7.1	1.04	8.2	1.23	8.8	1.33	9.4	1.43	10.5	1.59	11.7	1.60
	12	5.9	0.88	7.1	1.08	8.2	1.27	8.8	1.37	9.4	1.47	10.5	1.68	11.7	1.69
	14	5.9	0.91	7.1	1.12	8.2	1.33	8.8	1.42	9.4	1.54	10.5	1.77	11.7	1.79
	16	5.9	0.94	7.1	1.16	8.2	1.38	8.8	1.49	9.4	1.62	10.5	1.85	11.7	1.88
	18	5.9	0.96	7.1	1.20	8.2	1.44	8.8	1.56	9.4	1.72	10.5	1.96	11.7	1.98
	20	5.9	1.00	7.1	1.25	8.2	1.52	8.8	1.68	9.4	1.84	10.5	2.05	11.7	2.07
	21	5.9	1.02	7.1	1.28	8.2	1.57	8.8	1.73	9.4	1.91	10.5	2.10	11.7	2.12
	23	5.9	1.08	7.1	1.37	8.2	1.69	8.8	1.86	9.4	2.04	10.5	2.20	11.7	2.22
	25	5.9	1.15	7.1	1.46	8.2	1.80	8.8	1.99	9.4	2.18	10.5	2.29	11.7	2.31
	27	5.9	1.23	7.1	1.56	8.2	1.93	8.8	2.13	9.4	2.32	10.5	2.40	11.7	2.42
	29	5.9	1.30	7.1	1.66	8.2	2.06	8.8	2.27	9.4	2.46	10.5	2.50	11.7	2.52
	31	5.9	1.39	7.1	1.77	8.2	2.19	8.8	2.42	9.4	2.58	10.5	2.59	11.7	2.61
	33	5.9	1.48	7.1	1.89	8.2	2.34	8.8	2.59	9.4	2.68	10.5	2.69	11.7	2.71
	35	5.9	1.57	7.1	2.01	8.2	2.49	8.8	2.76	9.4	2.78	10.5	2.79	11.5	2.81
	37	5.9	1.63	7.1	2.09	8.2	2.56	8.8	2.81	9.4	2.82	10.5	2.83	11.4	2.86
	39	5.9	1.70	7.1	2.17	8.2	2.63	8.8	2.85	9.4	2.87	10.5	2.88	11.2	2.90
	41	5.7	1.93	6.8	2.47	7.9	2.96	8.5	3.17	9.1	3.19	10.2	3.20	10.6	3.23
	43	5.6	2.05	6.7	2.63	7.8	3.11	8.4	3.31	8.9	3.32	10.0	3.33	10.3	3.37
46	5.3	2.19	6.3	2.82	7.3	3.29	7.8	3.45	8.4	3.46	9.1	3.47	9.4	3.50	
48	4.7	1.89	5.6	2.44	6.5	2.81	6.9	2.93	7.4	2.94	7.9	2.94	8.1	2.97	
70	10	5.2	0.85	6.2	1.04	7.2	1.23	7.7	1.33	8.2	1.43	9.2	1.59	10.2	1.60
	12	5.2	0.88	6.2	1.08	7.2	1.27	7.7	1.37	8.2	1.47	9.2	1.68	10.2	1.69
	14	5.2	0.91	6.2	1.12	7.2	1.33	7.7	1.42	8.2	1.54	9.2	1.77	10.2	1.79
	16	5.2	0.94	6.2	1.16	7.2	1.38	7.7	1.49	8.2	1.62	9.2	1.85	10.2	1.88
	18	5.2	0.96	6.2	1.20	7.2	1.44	7.7	1.56	8.2	1.70	9.2	1.93	10.2	1.98
	20	5.2	1.00	6.2	1.25	7.2	1.50	7.7	1.62	8.2	1.74	9.2	1.98	10.2	2.07
	21	5.2	1.02	6.2	1.28	7.2	1.52	7.7	1.64	8.2	1.75	9.2	2.01	10.2	2.12
	23	5.2	1.08	6.2	1.32	7.2	1.55	7.7	1.69	8.2	1.84	9.2	2.15	10.2	2.22
	25	5.2	1.12	6.2	1.37	7.2	1.65	7.7	1.81	8.2	1.97	9.2	2.29	10.2	2.31
	27	5.2	1.18	6.2	1.46	7.2	1.76	7.7	1.92	8.2	2.10	9.2	2.40	10.2	2.42
	29	5.2	1.26	6.2	1.55	7.2	1.87	7.7	2.04	8.2	2.23	9.2	2.50	10.2	2.52
	31	5.2	1.34	6.2	1.65	7.2	2.00	7.7	2.18	8.2	2.38	9.2	2.59	10.2	2.61
	33	5.2	1.42	6.2	1.75	7.2	2.12	7.7	2.32	8.2	2.53	9.2	2.69	10.2	2.71
	35	5.2	1.50	6.2	1.86	7.2	2.26	7.7	2.47	8.2	2.69	9.2	2.79	10.2	2.81
	37	5.2	1.59	6.2	1.97	7.2	2.40	7.7	2.62	8.2	2.82	9.2	2.83	10.2	2.86
	39	5.2	1.67	6.2	2.08	7.2	2.54	7.7	2.77	8.2	2.87	9.2	2.88	10.2	2.90
	41	5.0	1.92	6.0	2.40	6.9	2.93	7.4	3.17	7.9	3.19	8.9	3.20	9.9	3.23
	43	4.9	2.05	5.9	2.59	6.8	3.11	7.3	3.31	7.8	3.32	8.7	3.33	9.7	3.37
46	4.6	2.19	5.5	2.82	6.4	3.29	6.9	3.45	7.3	3.46	8.2	3.47	9.1	3.50	
48	4.1	1.89	4.9	2.44	5.7	2.81	6.1	2.93	6.5	2.94	7.2	2.94	8.0	2.97	
60	10	4.4	0.81	5.3	0.96	6.2	1.11	6.6	1.19	7.0	1.27	7.9	1.44	8.8	1.60
	12	4.4	0.83	5.3	0.97	6.2	1.13	6.6	1.21	7.0	1.29	7.9	1.46	8.8	1.64
	14	4.4	0.84	5.3	0.98	6.2	1.15	6.6	1.23	7.0	1.31	7.9	1.49	8.8	1.67
	16	4.4	0.85	5.3	1.01	6.2	1.16	6.6	1.25	7.0	1.34	7.9	1.52	8.8	1.70
	18	4.4	0.87	5.3	1.02	6.2	1.18	6.6	1.27	7.0	1.36	7.9	1.54	8.8	1.73
	20	4.4	0.88	5.3	1.04	6.2	1.21	6.6	1.30	7.0	1.38	7.9	1.57	8.8	1.77
	21	4.4	0.89	5.3	1.04	6.2	1.22	6.6	1.31	7.0	1.40	7.9	1.59	8.8	1.78
	23	4.4	0.90	5.3	1.07	6.2	1.24	6.6	1.33	7.0	1.43	7.9	1.65	8.8	1.90
	25	4.4	0.92	5.3	1.09	6.2	1.29	6.6	1.40	7.0	1.52	7.9	1.76	8.8	2.03
	27	4.4	0.95	5.3	1.15	6.2	1.37	6.6	1.49	7.0	1.61	7.9	1.87	8.8	2.16
	29	4.4	1.01	5.3	1.22	6.2	1.46	6.6	1.58	7.0	1.72	7.9	2.00	8.8	2.31

7. Capacity Tables

Combination	Outdoor Air Temperature (°C DB)	Indoor Air Temperature (°C, DB/WB)													
		20.0 / 14.0		23.0 / 16.0		26.0 / 18.0		27.0 / 19.0		28.0 / 20.0		30.0 / 22.0		32.0 / 24.0	
		TC	PI	TC	PI	TC	PI	TC	PI	TC	PI	TC	PI	TC	PI
60	31	4.4	1.07	5.3	1.30	6.2	1.55	6.6	1.69	7.0	1.83	7.9	2.13	8.8	2.46
	33	4.4	1.13	5.3	1.37	6.2	1.64	6.6	1.79	7.0	1.95	7.9	2.27	8.8	2.62
	35	4.4	1.19	5.3	1.46	6.2	1.75	6.6	1.90	7.0	2.07	7.9	2.41	8.8	2.78
	37	4.4	1.26	5.3	1.54	6.2	1.85	6.6	2.02	7.0	2.19	7.9	2.56	8.8	2.86
	39	4.4	1.33	5.3	1.62	6.2	1.96	6.6	2.15	7.0	2.31	7.9	2.72	8.8	2.90
	41	4.3	1.51	5.1	1.87	6.0	2.26	6.4	2.47	6.8	2.67	7.6	3.14	8.5	3.23
	43	4.2	1.63	5.0	2.01	5.9	2.44	6.3	2.66	6.7	2.88	7.5	3.33	8.3	3.37
	46	4.0	1.77	4.7	2.19	5.5	2.66	5.9	2.90	6.3	3.14	7.0	3.47	7.8	3.50
50	10	3.7	0.66	4.4	0.77	5.1	0.87	5.5	0.94	5.9	0.99	6.6	1.12	7.3	1.24
	12	3.7	0.67	4.4	0.77	5.1	0.89	5.5	0.95	5.9	1.01	6.6	1.14	7.3	1.26
	14	3.7	0.68	4.4	0.79	5.1	0.90	5.5	0.96	5.9	1.03	6.6	1.15	7.3	1.28
	16	3.7	0.69	4.4	0.80	5.1	0.91	5.5	0.98	5.9	1.04	6.6	1.17	7.3	1.30
	18	3.7	0.70	4.4	0.81	5.1	0.93	5.5	1.00	5.9	1.06	6.6	1.19	7.3	1.33
	20	3.7	0.70	4.4	0.82	5.1	0.95	5.5	1.01	5.9	1.08	6.6	1.21	7.3	1.36
	21	3.7	0.71	4.4	0.83	5.1	0.96	5.5	1.03	5.9	1.09	6.6	1.23	7.3	1.37
	23	3.7	0.73	4.4	0.84	5.1	0.97	5.5	1.04	5.9	1.11	6.6	1.25	7.3	1.40
	25	3.7	0.73	4.4	0.86	5.1	0.99	5.5	1.06	5.9	1.14	6.6	1.31	7.3	1.50
	27	3.7	0.75	4.4	0.89	5.1	1.05	5.5	1.13	5.9	1.21	6.6	1.40	7.3	1.60
	29	3.7	0.79	4.4	0.94	5.1	1.11	5.5	1.20	5.9	1.29	6.6	1.49	7.3	1.70
	31	3.7	0.83	4.4	1.00	5.1	1.18	5.5	1.27	5.9	1.37	6.6	1.58	7.3	1.81
	33	3.7	0.88	4.4	1.05	5.1	1.25	5.5	1.35	5.9	1.46	6.6	1.68	7.3	1.93
	35	3.7	0.93	4.4	1.12	5.1	1.32	5.5	1.43	5.9	1.54	6.6	1.78	7.3	2.04
	37	3.7	0.98	4.4	1.18	5.1	1.40	5.5	1.51	5.9	1.63	6.6	1.90	7.3	2.17
	39	3.7	1.03	4.4	1.24	5.1	1.48	5.5	1.60	5.9	1.72	6.6	2.00	7.3	2.30
	41	3.6	1.18	4.3	1.43	5.0	1.70	5.3	1.84	5.6	1.98	6.3	2.31	7.0	2.65
	43	3.5	1.27	4.2	1.53	4.9	1.83	5.2	1.98	5.6	2.13	6.2	2.49	6.9	2.86
46	3.3	1.38	4.0	1.67	4.6	2.00	4.9	2.16	5.2	2.32	5.8	2.72	6.5	3.13	
48	2.9	1.20	3.5	1.46	4.1	1.74	4.3	1.88	4.6	2.02	5.2	2.38	5.8	2.73	

Note

- TC: Total Capacity(kW), PI : Power Input(kW, Comp. + Outdoor fan motor)
- Capacity tables show the average value of conditions which may occur.

7. Capacity Tables

ARUV050GSD6 [ARUV050GSD6]

Combination	Outdoor Air Temperature (°C DB)	Indoor Air Temperature (°C, DB/WB)													
		20.0 / 14.0		23.0 / 16.0		26.0 / 18.0		27.0 / 19.0		28.0 / 20.0		30.0 / 22.0		32.0 / 24.0	
		TC	PI	TC	PI	TC	PI	TC	PI	TC	PI	TC	PI	TC	PI
130	10	13.3	1.58	15.8	1.93	18.3	2.24	19.0	2.29	19.2	2.31	19.7	2.33	20.2	2.34
	12	13.3	1.62	15.8	2.00	18.3	2.34	18.8	2.35	19.1	2.40	19.5	2.42	19.9	2.43
	14	13.3	1.68	15.8	2.08	18.3	2.42	18.5	2.44	18.8	2.48	19.2	2.51	19.7	2.53
	16	13.3	1.74	15.8	2.15	18.1	2.53	18.3	2.56	18.5	2.57	19.0	2.60	19.5	2.62
	18	13.3	1.81	15.8	2.27	17.8	2.67	18.0	2.69	18.3	2.71	18.8	2.72	19.2	2.74
	20	13.3	1.89	15.8	2.42	17.5	2.80	17.8	2.82	18.0	2.84	18.5	2.85	19.0	2.87
	21	13.3	1.94	15.8	2.51	17.4	2.86	17.7	2.89	17.9	2.90	18.4	2.92	18.9	2.94
	23	13.3	2.08	15.8	2.69	17.2	2.98	17.4	3.01	17.7	3.04	18.1	3.05	18.6	3.07
	25	13.3	2.22	15.8	2.87	16.9	3.12	17.2	3.15	17.4	3.17	17.9	3.18	18.4	3.20
	27	13.3	2.38	15.8	3.07	16.7	3.25	16.9	3.27	17.2	3.30	17.7	3.32	18.1	3.34
	29	13.3	2.53	15.8	3.28	16.4	3.38	16.7	3.41	16.9	3.43	17.4	3.45	17.9	3.47
	31	13.3	2.70	15.7	3.46	16.2	3.52	16.4	3.54	16.7	3.56	17.1	3.58	17.6	3.60
	33	13.3	2.88	15.5	3.59	16.0	3.65	16.2	3.68	16.4	3.70	16.9	3.71	17.3	3.74
	35	13.3	3.07	15.2	3.72	15.7	3.79	16.0	3.81	16.2	3.83	16.6	3.85	17.1	3.87
	37	13.3	3.18	15.0	3.79	15.5	3.86	15.7	3.89	16.0	3.91	16.4	3.92	16.9	3.95
	39	13.3	3.29	14.7	3.87	15.2	3.94	15.5	3.97	15.7	3.98	16.2	3.99	16.6	4.02
	41	12.8	3.72	14.0	4.32	14.4	4.40	14.7	4.43	14.9	4.44	15.4	4.46	15.8	4.49
	43	12.6	3.94	13.5	4.52	14.0	4.60	14.2	4.63	14.5	4.65	14.9	4.66	15.3	4.70
46	11.8	4.20	12.3	4.73	12.8	4.82	13.0	4.85	13.2	4.86	13.7	4.87	14.0	4.91	
48	10.4	3.61	10.7	4.04	11.1	4.11	11.3	4.12	11.5	4.13	11.9	4.15	12.2	4.17	
120	10	12.3	1.42	14.6	1.75	17.0	2.07	18.1	2.24	19.0	2.28	19.4	2.29	19.9	2.30
	12	12.3	1.46	14.6	1.80	17.0	2.16	18.1	2.29	18.7	2.36	19.2	2.39	19.6	2.40
	14	12.3	1.51	14.6	1.87	17.0	2.24	18.1	2.38	18.5	2.45	19.0	2.48	19.4	2.51
	16	12.3	1.57	14.6	1.94	17.0	2.33	18.0	2.50	18.3	2.56	18.7	2.57	19.1	2.60
	18	12.3	1.63	14.6	2.03	17.0	2.47	17.8	2.64	18.0	2.69	18.4	2.70	18.9	2.71
	20	12.3	1.69	14.6	2.15	17.0	2.63	17.5	2.80	17.8	2.82	18.2	2.83	18.6	2.85
	21	12.3	1.74	14.6	2.23	17.0	2.73	17.4	2.86	17.6	2.89	18.1	2.90	18.5	2.91
	23	12.3	1.86	14.6	2.39	17.0	2.91	17.2	2.99	17.4	3.02	17.8	3.03	18.3	3.04
	25	12.3	1.99	14.6	2.56	16.7	3.07	16.9	3.12	17.1	3.15	17.6	3.16	18.0	3.18
	27	12.3	2.12	14.6	2.73	16.5	3.22	16.7	3.25	16.9	3.28	17.3	3.30	17.8	3.31
	29	12.3	2.26	14.6	2.92	16.2	3.36	16.4	3.38	16.6	3.41	17.1	3.43	17.5	3.44
	31	12.3	2.41	14.6	3.11	15.9	3.50	16.2	3.51	16.4	3.55	16.8	3.56	17.3	3.57
	33	12.3	2.57	14.6	3.32	15.7	3.62	15.9	3.65	16.1	3.68	16.6	3.69	17.0	3.71
	35	12.3	2.73	14.6	3.54	15.4	3.77	15.7	3.78	15.9	3.81	16.4	3.82	16.8	3.84
	37	12.3	2.85	14.6	3.63	15.2	3.83	15.4	3.85	15.7	3.87	16.1	3.89	16.5	3.90
	39	12.3	2.97	14.5	3.71	15.0	3.90	15.2	3.92	15.4	3.93	15.9	3.96	16.3	3.97
	41	11.8	3.39	13.8	4.16	14.2	4.34	14.4	4.37	14.6	4.38	15.1	4.41	15.5	4.42
	43	11.7	3.62	13.3	4.37	13.8	4.53	14.0	4.57	14.2	4.58	14.6	4.61	15.0	4.62
46	10.9	3.89	12.1	4.60	12.6	4.73	12.8	4.77	13.0	4.79	13.3	4.80	13.7	4.81	
48	9.7	3.37	10.5	3.93	10.9	4.02	11.1	4.05	11.3	4.06	11.6	4.08	12.0	4.09	
110	10	11.2	1.28	13.4	1.56	15.5	1.85	16.6	2.01	17.7	2.16	19.0	2.25	19.5	2.26
	12	11.2	1.32	13.4	1.61	15.5	1.93	16.6	2.06	17.7	2.24	18.8	2.33	19.2	2.37
	14	11.2	1.36	13.4	1.69	15.5	2.02	16.6	2.17	17.7	2.35	18.6	2.42	19.0	2.47
	16	11.2	1.41	13.4	1.75	15.5	2.10	16.6	2.26	17.7	2.50	18.3	2.56	18.7	2.57
	18	11.2	1.46	13.4	1.82	15.5	2.22	16.6	2.41	17.7	2.64	18.1	2.69	18.5	2.70
	20	11.2	1.51	13.4	1.91	15.5	2.36	16.6	2.57	17.4	2.79	17.9	2.82	18.2	2.83
	21	11.2	1.55	13.4	1.97	15.5	2.44	16.6	2.66	17.3	2.85	17.7	2.88	18.1	2.89
23	11.2	1.65	13.4	2.11	15.5	2.62	16.6	2.82	17.0	2.99	17.5	3.01	17.9	3.03	

7. Capacity Tables

Combination	Outdoor Air Temperature (°C DB)	Indoor Air Temperature (°C, DB/WB)													
		20.0 / 14.0		23.0 / 16.0		26.0 / 18.0		27.0 / 19.0		28.0 / 20.0		30.0 / 22.0		32.0 / 24.0	
		TC	PI	TC	PI	TC	PI	TC	PI	TC	PI	TC	PI	TC	PI
110	25	11.2	1.76	13.4	2.25	15.5	2.80	16.6	2.99	16.8	3.11	17.2	3.15	17.6	3.16
	27	11.2	1.88	13.4	2.41	15.5	3.00	16.3	3.15	16.6	3.26	17.0	3.28	17.4	3.29
	29	11.2	2.01	13.4	2.57	15.5	3.20	16.1	3.29	16.3	3.39	16.7	3.41	17.1	3.42
	31	11.2	2.14	13.4	2.74	15.5	3.42	15.9	3.43	16.1	3.52	16.5	3.54	16.9	3.55
	33	11.2	2.28	13.4	2.92	15.4	3.61	15.6	3.59	15.9	3.65	16.2	3.67	16.7	3.68
	35	11.2	2.42	13.4	3.11	15.2	3.74	15.4	3.75	15.6	3.79	16.0	3.80	16.4	3.82
	37	11.2	2.52	13.4	3.21	14.9	3.80	15.2	3.81	15.3	3.84	15.7	3.86	16.1	3.88
	39	11.2	2.61	13.4	3.30	14.7	3.86	14.9	3.87	15.1	3.90	15.5	3.92	15.9	3.94
	41	10.8	2.97	12.9	3.72	13.9	4.30	14.1	4.31	14.3	4.34	14.7	4.36	15.1	4.37
	43	10.7	3.16	12.7	3.93	13.5	4.48	13.7	4.49	13.9	4.52	14.3	4.55	14.6	4.56
	46	10.0	3.38	11.9	4.16	12.3	4.67	12.5	4.68	12.7	4.71	13.0	4.73	13.4	4.74
	48	8.8	2.92	10.4	3.57	10.7	3.95	10.9	3.98	11.0	4.00	11.3	4.01	11.6	4.03
100	10	9.8	1.15	11.7	1.40	13.6	1.66	14.5	1.80	15.4	1.93	17.3	2.15	19.1	2.17
	12	9.8	1.19	11.7	1.46	13.6	1.72	14.5	1.84	15.4	1.99	17.3	2.26	18.8	2.29
	14	9.8	1.23	11.7	1.52	13.6	1.79	14.5	1.92	15.4	2.08	17.3	2.39	18.6	2.41
	16	9.8	1.26	11.7	1.57	13.6	1.87	14.5	2.02	15.4	2.19	17.3	2.51	18.3	2.54
	18	9.8	1.30	11.7	1.63	13.6	1.94	14.5	2.11	15.4	2.32	17.3	2.65	18.1	2.67
	20	9.8	1.35	11.7	1.69	13.6	2.05	14.5	2.26	15.4	2.48	17.3	2.77	17.8	2.80
	21	9.8	1.38	11.7	1.73	13.6	2.12	14.5	2.34	15.4	2.58	17.3	2.84	17.7	2.86
	23	9.8	1.46	11.7	1.85	13.6	2.28	14.5	2.51	15.4	2.76	17.1	2.97	17.5	3.00
	25	9.8	1.55	11.7	1.97	13.6	2.43	14.5	2.69	15.4	2.95	16.9	3.10	17.2	3.12
	27	9.8	1.66	11.7	2.10	13.6	2.60	14.5	2.87	15.4	3.14	16.6	3.24	17.0	3.27
	29	9.8	1.76	11.7	2.24	13.6	2.78	14.5	3.07	15.4	3.32	16.4	3.38	16.7	3.40
	31	9.8	1.88	11.7	2.39	13.6	2.97	14.5	3.28	15.4	3.49	16.1	3.51	16.5	3.53
	33	9.8	2.00	11.7	2.55	13.6	3.16	14.5	3.50	15.4	3.62	15.9	3.64	16.2	3.67
	35	9.8	2.12	11.7	2.71	13.6	3.37	14.5	3.73	15.2	3.75	15.6	3.77	16.0	3.80
	37	9.8	2.21	11.7	2.82	13.6	3.46	14.5	3.79	14.9	3.81	15.4	3.83	15.7	3.86
	39	9.8	2.29	11.7	2.94	13.6	3.56	14.5	3.86	14.7	3.87	15.1	3.89	15.5	3.92
41	9.4	2.60	11.2	3.34	13.1	3.99	13.8	4.29	13.9	4.31	14.0	4.32	14.7	4.36	
43	9.3	2.77	11.1	3.56	12.9	4.21	13.3	4.48	13.5	4.49	13.9	4.51	14.3	4.55	
46	8.7	2.96	10.4	3.82	12.1	4.44	12.2	4.66	12.3	4.68	12.7	4.69	13.0	4.73	
48	7.7	2.56	9.2	3.30	10.4	3.80	10.6	3.96	10.7	3.97	11.0	3.98	11.3	4.01	
90	10	8.8	1.15	10.5	1.40	12.2	1.66	13.1	1.80	13.9	1.93	15.6	2.15	17.3	2.17
	12	8.8	1.19	10.5	1.46	12.2	1.72	13.1	1.84	13.9	1.99	15.6	2.26	17.3	2.29
	14	8.8	1.23	10.5	1.52	12.2	1.79	13.1	1.92	13.9	2.08	15.6	2.39	17.3	2.41
	16	8.8	1.26	10.5	1.57	12.2	1.87	13.1	2.02	13.9	2.19	15.6	2.51	17.3	2.54
	18	8.8	1.30	10.5	1.63	12.2	1.94	13.1	2.11	13.9	2.32	15.6	2.65	17.3	2.67
	20	8.8	1.35	10.5	1.69	12.2	2.05	13.1	2.26	13.9	2.48	15.6	2.77	17.3	2.80
	21	8.8	1.38	10.5	1.73	12.2	2.12	13.1	2.34	13.9	2.58	15.6	2.84	17.3	2.86
	23	8.8	1.46	10.5	1.85	12.2	2.28	13.1	2.51	13.9	2.76	15.6	2.97	17.1	3.00
	25	8.8	1.55	10.5	1.97	12.2	2.43	13.1	2.69	13.9	2.95	15.6	3.10	16.8	3.12
	27	8.8	1.66	10.5	2.10	12.2	2.60	13.1	2.87	13.9	3.14	15.6	3.24	16.6	3.27
	29	8.8	1.76	10.5	2.24	12.2	2.78	13.1	3.07	13.9	3.32	15.6	3.38	16.3	3.40
	31	8.8	1.88	10.5	2.39	12.2	2.97	13.1	3.28	13.9	3.49	15.6	3.51	16.1	3.53
	33	8.8	2.00	10.5	2.55	12.2	3.16	13.1	3.50	13.9	3.62	15.6	3.64	15.8	3.67
	35	8.8	2.12	10.5	2.71	12.2	3.37	13.1	3.73	13.9	3.75	15.3	3.77	15.6	3.80
	37	8.8	2.21	10.5	2.82	12.2	3.46	13.1	3.79	13.9	3.81	15.1	3.83	15.3	3.86
	39	8.8	2.29	10.5	2.94	12.2	3.56	13.1	3.86	13.9	3.87	14.8	3.89	15.1	3.92
41	8.5	2.60	10.1	3.34	11.8	3.99	12.6	4.29	13.4	4.31	14.1	4.32	14.3	4.36	
43	8.4	2.77	10.0	3.56	11.6	4.21	12.4	4.48	13.2	4.49	13.6	4.51	13.9	4.55	
46	7.8	2.96	9.4	3.82	10.9	4.44	11.6	4.66	12.0	4.68	12.4	4.69	12.7	4.73	
48	6.9	2.56	8.3	3.30	9.6	3.80	10.3	3.96	10.4	3.97	10.8	3.98	11.0	4.01	

7. Capacity Tables

Combination	Outdoor Air Temperature (°C DB)	Indoor Air Temperature (°C, DB/WB)													
		20.0 / 14.0		23.0 / 16.0		26.0 / 18.0		27.0 / 19.0		28.0 / 20.0		30.0 / 22.0		32.0 / 24.0	
		TC	PI	TC	PI	TC	PI	TC	PI	TC	PI	TC	PI	TC	PI
80	10	7.8	1.15	9.3	1.40	10.8	1.66	11.6	1.80	12.4	1.93	13.9	2.15	15.4	2.17
	12	7.8	1.19	9.3	1.46	10.8	1.72	11.6	1.84	12.4	1.99	13.9	2.26	15.4	2.29
	14	7.8	1.23	9.3	1.52	10.8	1.79	11.6	1.92	12.4	2.08	13.9	2.39	15.4	2.41
	16	7.8	1.26	9.3	1.57	10.8	1.87	11.6	2.02	12.4	2.19	13.9	2.51	15.4	2.54
	18	7.8	1.30	9.3	1.63	10.8	1.94	11.6	2.11	12.4	2.32	13.9	2.65	15.4	2.67
	20	7.8	1.35	9.3	1.69	10.8	2.05	11.6	2.26	12.4	2.48	13.9	2.77	15.4	2.80
	21	7.8	1.38	9.3	1.73	10.8	2.12	11.6	2.34	12.4	2.58	13.9	2.84	15.4	2.86
	23	7.8	1.46	9.3	1.85	10.8	2.28	11.6	2.51	12.4	2.76	13.9	2.97	15.4	3.00
	25	7.8	1.55	9.3	1.97	10.8	2.43	11.6	2.69	12.4	2.95	13.9	3.10	15.4	3.12
	27	7.8	1.66	9.3	2.10	10.8	2.60	11.6	2.87	12.4	3.14	13.9	3.24	15.4	3.27
	29	7.8	1.76	9.3	2.24	10.8	2.78	11.6	3.07	12.4	3.32	13.9	3.38	15.4	3.40
	31	7.8	1.88	9.3	2.39	10.8	2.97	11.6	3.28	12.4	3.49	13.9	3.51	15.4	3.53
	33	7.8	2.00	9.3	2.55	10.8	3.16	11.6	3.50	12.4	3.62	13.9	3.64	15.4	3.67
	35	7.8	2.12	9.3	2.71	10.8	3.37	11.6	3.73	12.4	3.75	13.9	3.77	15.2	3.80
	37	7.8	2.21	9.3	2.82	10.8	3.46	11.6	3.79	12.4	3.81	13.9	3.83	15.0	3.86
	39	7.8	2.29	9.3	2.94	10.8	3.56	11.6	3.86	12.4	3.87	13.9	3.89	14.7	3.92
	41	7.5	2.60	9.0	3.34	10.4	3.99	11.2	4.29	11.9	4.31	13.4	4.32	14.0	4.36
43	7.4	2.77	8.9	3.56	10.3	4.21	11.0	4.48	11.8	4.49	13.2	4.51	13.5	4.55	
46	7.0	2.96	8.3	3.82	9.6	4.44	10.3	4.66	11.0	4.68	12.1	4.69	12.3	4.73	
48	6.2	2.56	7.3	3.30	8.5	3.80	9.1	3.96	9.8	3.97	10.5	3.98	10.7	4.01	
70	10	6.8	1.15	8.2	1.40	9.5	1.66	10.2	1.80	10.8	1.93	12.1	2.15	13.5	2.17
	12	6.8	1.19	8.2	1.46	9.5	1.72	10.2	1.84	10.8	1.99	12.1	2.26	13.5	2.29
	14	6.8	1.23	8.2	1.52	9.5	1.79	10.2	1.92	10.8	2.08	12.1	2.39	13.5	2.41
	16	6.8	1.26	8.2	1.57	9.5	1.87	10.2	2.02	10.8	2.19	12.1	2.51	13.5	2.54
	18	6.8	1.30	8.2	1.63	9.5	1.94	10.2	2.11	10.8	2.30	12.1	2.61	13.5	2.67
	20	6.8	1.35	8.2	1.69	9.5	2.03	10.2	2.19	10.8	2.35	12.1	2.68	13.5	2.80
	21	6.8	1.38	8.2	1.73	9.5	2.05	10.2	2.21	10.8	2.37	12.1	2.72	13.5	2.86
	23	6.8	1.46	8.2	1.79	9.5	2.10	10.2	2.29	10.8	2.49	12.1	2.91	13.5	3.00
	25	6.8	1.51	8.2	1.85	9.5	2.23	10.2	2.44	10.8	2.66	12.1	3.10	13.5	3.12
	27	6.8	1.60	8.2	1.98	9.5	2.38	10.2	2.59	10.8	2.84	12.1	3.24	13.5	3.27
	29	6.8	1.70	8.2	2.10	9.5	2.53	10.2	2.76	10.8	3.02	12.1	3.38	13.5	3.40
	31	6.8	1.81	8.2	2.23	9.5	2.70	10.2	2.95	10.8	3.22	12.1	3.51	13.5	3.53
	33	6.8	1.92	8.2	2.36	9.5	2.87	10.2	3.13	10.8	3.42	12.1	3.64	13.5	3.67
	35	6.8	2.02	8.2	2.52	9.5	3.05	10.2	3.33	10.8	3.64	12.1	3.77	13.5	3.80
	37	6.8	2.15	8.2	2.67	9.5	3.24	10.2	3.55	10.8	3.81	12.1	3.83	13.5	3.86
	39	6.8	2.26	8.2	2.82	9.5	3.43	10.2	3.74	10.8	3.87	12.1	3.89	13.5	3.92
	41	6.6	2.60	7.9	3.25	9.1	3.96	9.8	4.29	10.4	4.31	11.7	4.32	13.0	4.36
43	6.5	2.77	7.8	3.50	9.0	4.21	9.6	4.48	10.3	4.49	11.5	4.51	12.8	4.55	
46	6.1	2.96	7.3	3.82	8.4	4.44	9.0	4.66	9.6	4.68	10.8	4.69	12.0	4.73	
48	5.4	2.56	6.4	3.30	7.5	3.80	8.0	3.96	8.5	3.97	9.5	3.98	10.6	4.01	
60	10	5.9	1.10	7.0	1.29	8.1	1.50	8.7	1.61	9.3	1.71	10.4	1.94	11.5	2.17
	12	5.9	1.12	7.0	1.31	8.1	1.52	8.7	1.63	9.3	1.74	10.4	1.97	11.5	2.21
	14	5.9	1.13	7.0	1.33	8.1	1.55	8.7	1.66	9.3	1.77	10.4	2.01	11.5	2.25
	16	5.9	1.15	7.0	1.36	8.1	1.57	8.7	1.69	9.3	1.81	10.4	2.05	11.5	2.29
	18	5.9	1.17	7.0	1.38	8.1	1.60	8.7	1.72	9.3	1.84	10.4	2.08	11.5	2.34
	20	5.9	1.19	7.0	1.40	8.1	1.63	8.7	1.75	9.3	1.87	10.4	2.12	11.5	2.39
	21	5.9	1.20	7.0	1.41	8.1	1.65	8.7	1.77	9.3	1.89	10.4	2.15	11.5	2.41
	23	5.9	1.22	7.0	1.44	8.1	1.67	8.7	1.80	9.3	1.93	10.4	2.23	11.5	2.56
	25	5.9	1.24	7.0	1.47	8.1	1.74	8.7	1.89	9.3	2.05	10.4	2.38	11.5	2.74
	27	5.9	1.28	7.0	1.55	8.1	1.85	8.7	2.01	9.3	2.18	10.4	2.53	11.5	2.92
	29	5.9	1.36	7.0	1.65	8.1	1.97	8.7	2.14	9.3	2.32	10.4	2.70	11.5	3.12

7. Capacity Tables

Combination	Outdoor Air Temperature (°C DB)	Indoor Air Temperature (°C, DB/WB)													
		20.0 / 14.0		23.0 / 16.0		26.0 / 18.0		27.0 / 19.0		28.0 / 20.0		30.0 / 22.0		32.0 / 24.0	
		TC	PI	TC	PI	TC	PI	TC	PI	TC	PI	TC	PI	TC	PI
60	31	5.9	1.44	7.0	1.75	8.1	2.09	8.7	2.28	9.3	2.47	10.4	2.88	11.5	3.32
	33	5.9	1.52	7.0	1.85	8.1	2.22	8.7	2.42	9.3	2.63	10.4	3.06	11.5	3.54
	35	5.9	1.61	7.0	1.97	8.1	2.36	8.7	2.57	9.3	2.79	10.4	3.26	11.5	3.76
	37	5.9	1.70	7.0	2.08	8.1	2.50	8.7	2.73	9.3	2.96	10.4	3.46	11.5	3.86
	39	5.9	1.79	7.0	2.19	8.1	2.65	8.7	2.90	9.3	3.12	10.4	3.68	11.5	3.92
	41	5.6	2.04	6.7	2.52	7.8	3.05	8.4	3.33	8.9	3.60	10.0	4.24	11.1	4.36
	43	5.6	2.20	6.6	2.72	7.7	3.30	8.3	3.60	8.8	3.89	9.9	4.51	11.0	4.55
	46	5.2	2.39	6.2	2.96	7.2	3.60	7.7	3.92	8.3	4.25	9.3	4.69	10.3	4.73
	48	4.6	2.08	5.5	2.59	6.4	3.14	6.9	3.43	7.3	3.71	8.2	3.98	9.1	4.01
50	10	4.9	0.90	5.9	1.04	6.8	1.18	7.3	1.26	7.7	1.34	8.6	1.51	9.6	1.68
	12	4.9	0.91	5.9	1.05	6.8	1.20	7.3	1.28	7.7	1.37	8.6	1.54	9.6	1.71
	14	4.9	0.91	5.9	1.07	6.8	1.22	7.3	1.30	7.7	1.39	8.6	1.56	9.6	1.74
	16	4.9	0.93	5.9	1.08	6.8	1.24	7.3	1.33	7.7	1.41	8.6	1.58	9.6	1.76
	18	4.9	0.94	5.9	1.09	6.8	1.25	7.3	1.35	7.7	1.43	8.6	1.61	9.6	1.80
	20	4.9	0.95	5.9	1.11	6.8	1.28	7.3	1.37	7.7	1.46	8.6	1.64	9.6	1.84
	21	4.9	0.96	5.9	1.12	6.8	1.29	7.3	1.39	7.7	1.47	8.6	1.66	9.6	1.86
	23	4.9	0.98	5.9	1.14	6.8	1.31	7.3	1.41	7.7	1.50	8.6	1.69	9.6	1.90
	25	4.9	0.99	5.9	1.16	6.8	1.34	7.3	1.43	7.7	1.55	8.6	1.77	9.6	2.03
	27	4.9	1.01	5.9	1.20	6.8	1.41	7.3	1.53	7.7	1.64	8.6	1.90	9.6	2.16
	29	4.9	1.07	5.9	1.27	6.8	1.50	7.3	1.62	7.7	1.74	8.6	2.01	9.6	2.29
	31	4.9	1.12	5.9	1.35	6.8	1.59	7.3	1.72	7.7	1.86	8.6	2.14	9.6	2.44
	33	4.9	1.19	5.9	1.42	6.8	1.69	7.3	1.82	7.7	1.97	8.6	2.27	9.6	2.60
	35	4.9	1.25	5.9	1.51	6.8	1.78	7.3	1.93	7.7	2.08	8.6	2.40	9.6	2.76
	37	4.9	1.33	5.9	1.59	6.8	1.89	7.3	2.05	7.7	2.21	8.6	2.57	9.6	2.93
	39	4.9	1.39	5.9	1.67	6.8	2.00	7.3	2.16	7.7	2.32	8.6	2.71	9.6	3.11
	41	4.7	1.60	5.6	1.93	6.5	2.30	7.0	2.49	7.4	2.67	8.3	3.12	9.3	3.58
	43	4.7	1.72	5.6	2.07	6.4	2.48	6.9	2.68	7.3	2.88	8.2	3.37	9.2	3.87
46	4.4	1.87	5.2	2.26	6.0	2.70	6.5	2.92	6.9	3.14	7.7	3.67	8.6	4.22	
48	3.9	1.63	4.6	1.97	5.3	2.35	5.7	2.55	6.1	2.74	6.8	3.21	7.6	3.69	

Note

- TC: Total Capacity(kW), PI : Power Input(kW, Comp. + Outdoor fan motor)
- Capacity tables show the average value of conditions which may occur.

7. Capacity Tables

ARUV060GSD6 [ARUV060GSD6]

Combination	Outdoor Air Temperature (°C DB)	Indoor Air Temperature (°C, DB/WB)													
		20.0 / 14.0		23.0 / 16.0		26.0 / 18.0		27.0 / 19.0		28.0 / 20.0		30.0 / 22.0		32.0 / 24.0	
		TC	PI	TC	PI	TC	PI	TC	PI	TC	PI	TC	PI	TC	PI
130	10	14.6	1.75	17.4	2.14	20.2	2.48	21.0	2.53	21.2	2.56	21.8	2.57	22.3	2.59
	12	14.6	1.80	17.4	2.22	20.2	2.59	20.7	2.60	21.0	2.65	21.5	2.68	22.0	2.69
	14	14.6	1.86	17.4	2.30	20.2	2.68	20.5	2.70	20.7	2.75	21.2	2.78	21.8	2.80
	16	14.6	1.92	17.4	2.38	19.9	2.80	20.2	2.83	20.4	2.85	20.9	2.88	21.5	2.90
	18	14.6	2.00	17.4	2.52	19.6	2.95	19.9	2.98	20.2	3.00	20.7	3.01	21.2	3.03
	20	14.6	2.09	17.4	2.68	19.3	3.10	19.7	3.12	19.9	3.14	20.4	3.16	20.9	3.18
	21	14.6	2.15	17.4	2.77	19.2	3.17	19.5	3.20	19.7	3.22	20.3	3.23	20.8	3.25
	23	14.6	2.30	17.4	2.98	19.0	3.30	19.2	3.33	19.5	3.36	20.0	3.38	20.5	3.40
	25	14.6	2.46	17.4	3.18	18.7	3.45	19.0	3.48	19.2	3.51	19.7	3.52	20.3	3.55
	27	14.6	2.63	17.4	3.40	18.4	3.60	18.7	3.62	19.0	3.65	19.5	3.67	20.0	3.69
	29	14.6	2.81	17.4	3.64	18.1	3.75	18.4	3.77	18.7	3.80	19.2	3.82	19.7	3.84
	31	14.6	2.99	17.4	3.83	17.8	3.90	18.1	3.92	18.4	3.95	18.9	3.97	19.4	3.99
	33	14.6	3.19	17.1	3.98	17.6	4.04	17.9	4.07	18.1	4.09	18.7	4.11	19.1	4.14
	35	14.6	3.40	16.8	4.12	17.3	4.19	17.6	4.22	17.9	4.24	18.4	4.26	18.9	4.28
	37	14.6	3.52	16.5	4.20	17.1	4.28	17.3	4.31	17.6	4.33	18.1	4.34	18.6	4.37
	39	14.6	3.64	16.2	4.28	16.8	4.36	17.1	4.39	17.3	4.41	17.8	4.42	18.4	4.46
	41	14.1	4.12	15.4	4.78	15.9	4.87	16.2	4.90	16.5	4.92	17.0	4.93	17.4	4.97
	43	13.9	4.36	14.9	5.01	15.4	5.10	15.7	5.13	16.0	5.15	16.5	5.16	16.9	5.20
46	13.0	4.65	13.6	5.24	14.1	5.34	14.3	5.36	14.6	5.38	15.1	5.39	15.5	5.44	
48	11.5	4.00	11.8	4.47	12.3	4.55	12.5	4.56	12.7	4.57	13.1	4.59	13.5	4.62	
120	10	13.5	1.58	16.1	1.93	18.7	2.30	20.0	2.48	21.0	2.52	21.5	2.53	21.9	2.54
	12	13.5	1.62	16.1	2.00	18.7	2.39	20.0	2.53	20.7	2.61	21.2	2.65	21.6	2.66
	14	13.5	1.67	16.1	2.07	18.7	2.49	20.0	2.63	20.4	2.71	20.9	2.75	21.4	2.77
	16	13.5	1.73	16.1	2.15	18.7	2.58	19.9	2.77	20.1	2.84	20.6	2.85	21.1	2.88
	18	13.5	1.80	16.1	2.25	18.7	2.74	19.6	2.93	19.8	2.98	20.3	2.99	20.9	3.00
	20	13.5	1.87	16.1	2.38	18.7	2.92	19.4	3.10	19.6	3.13	20.1	3.14	20.6	3.15
	21	13.5	1.93	16.1	2.47	18.7	3.02	19.2	3.17	19.4	3.20	20.0	3.21	20.4	3.22
	23	13.5	2.06	16.1	2.64	18.7	3.22	19.0	3.31	19.2	3.34	19.7	3.36	20.1	3.37
	25	13.5	2.20	16.1	2.83	18.4	3.40	18.7	3.46	18.9	3.49	19.4	3.50	19.9	3.52
	27	13.5	2.35	16.1	3.03	18.2	3.57	18.4	3.60	18.7	3.64	19.1	3.65	19.6	3.66
	29	13.5	2.51	16.1	3.23	17.9	3.72	18.1	3.75	18.4	3.78	18.8	3.80	19.4	3.81
	31	13.5	2.67	16.1	3.45	17.6	3.87	17.9	3.89	18.1	3.93	18.6	3.94	19.1	3.96
	33	13.5	2.84	16.1	3.68	17.3	4.01	17.6	4.04	17.8	4.07	18.3	4.09	18.8	4.10
	35	13.5	3.03	16.1	3.92	17.0	4.17	17.3	4.18	17.6	4.22	18.1	4.23	18.5	4.25
	37	13.5	3.16	16.1	4.01	16.8	4.24	17.0	4.27	17.3	4.28	17.8	4.31	18.2	4.32
	39	13.5	3.29	16.0	4.11	16.5	4.31	16.7	4.34	17.0	4.36	17.5	4.38	18.0	4.40
	41	13.1	3.75	15.2	4.61	15.7	4.80	15.9	4.84	16.1	4.85	16.6	4.88	17.1	4.90
	43	12.9	4.00	14.7	4.84	15.2	5.02	15.4	5.06	15.6	5.07	16.1	5.10	16.6	5.11
46	12.0	4.31	13.4	5.09	13.9	5.24	14.1	5.28	14.3	5.30	14.7	5.32	15.2	5.33	
48	10.7	3.73	11.6	4.35	12.1	4.46	12.2	4.48	12.4	4.50	12.8	4.52	13.2	4.53	
110	10	12.4	1.42	14.8	1.73	17.1	2.05	18.3	2.22	19.5	2.39	21.0	2.49	21.5	2.50
	12	12.4	1.46	14.8	1.79	17.1	2.14	18.3	2.28	19.5	2.48	20.8	2.58	21.2	2.62
	14	12.4	1.51	14.8	1.87	17.1	2.23	18.3	2.40	19.5	2.61	20.5	2.68	21.0	2.74
	16	12.4	1.56	14.8	1.93	17.1	2.33	18.3	2.50	19.5	2.76	20.2	2.83	20.7	2.85
	18	12.4	1.62	14.8	2.02	17.1	2.46	18.3	2.67	19.5	2.93	19.9	2.98	20.4	2.99
	20	12.4	1.68	14.8	2.12	17.1	2.61	18.3	2.84	19.2	3.09	19.7	3.12	20.1	3.13
	21	12.4	1.71	14.8	2.18	17.1	2.70	18.3	2.94	19.1	3.16	19.5	3.19	20.0	3.21
23	12.4	1.83	14.8	2.34	17.1	2.90	18.3	3.12	18.8	3.31	19.3	3.34	19.7	3.35	

7. Capacity Tables

Combination	Outdoor Air Temperature (°C DB)	Indoor Air Temperature (°C, DB/WB)													
		20.0 / 14.0		23.0 / 16.0		26.0 / 18.0		27.0 / 19.0		28.0 / 20.0		30.0 / 22.0		32.0 / 24.0	
		TC	PI	TC	PI	TC	PI	TC	PI	TC	PI	TC	PI	TC	PI
110	25	12.4	1.95	14.8	2.49	17.1	3.10	18.3	3.31	18.6	3.45	19.0	3.48	19.5	3.50
	27	12.4	2.08	14.8	2.66	17.1	3.32	18.0	3.49	18.3	3.61	18.7	3.63	19.2	3.64
	29	12.4	2.23	14.8	2.84	17.1	3.54	17.8	3.64	18.0	3.76	18.5	3.77	18.9	3.79
	31	12.4	2.37	14.8	3.03	17.1	3.79	17.5	3.80	17.7	3.90	18.2	3.92	18.6	3.93
	33	12.4	2.52	14.8	3.23	17.0	4.00	17.3	3.97	17.5	4.05	17.9	4.06	18.4	4.08
	35	12.4	2.68	14.8	3.45	16.7	4.14	17.0	4.15	17.2	4.19	17.6	4.21	18.1	4.23
	37	12.4	2.78	14.8	3.55	16.5	4.21	16.7	4.22	16.9	4.25	17.4	4.28	17.8	4.29
	39	12.4	2.89	14.8	3.66	16.2	4.28	16.4	4.29	16.7	4.32	17.1	4.34	17.6	4.36
	41	11.9	3.28	14.2	4.12	15.3	4.76	15.6	4.77	15.8	4.80	16.2	4.83	16.6	4.84
	43	11.8	3.49	14.0	4.35	14.8	4.96	15.1	4.97	15.3	5.01	15.7	5.04	16.1	5.05
	46	11.0	3.74	13.1	4.60	13.5	5.17	13.8	5.18	14.0	5.21	14.4	5.24	14.8	5.25
	48	9.8	3.24	11.4	3.95	11.8	4.38	12.0	4.41	12.1	4.43	12.5	4.44	12.8	4.46
100	10	10.8	1.28	12.9	1.55	15.0	1.84	16.0	1.99	17.0	2.14	19.1	2.38	21.0	2.40
	12	10.8	1.32	12.9	1.62	15.0	1.90	16.0	2.04	17.0	2.21	19.1	2.51	20.7	2.53
	14	10.8	1.36	12.9	1.68	15.0	1.98	16.0	2.13	17.0	2.30	19.1	2.65	20.5	2.67
	16	10.8	1.40	12.9	1.74	15.0	2.07	16.0	2.23	17.0	2.42	19.1	2.78	20.2	2.81
	18	10.8	1.44	12.9	1.80	15.0	2.15	16.0	2.34	17.0	2.57	19.1	2.93	19.9	2.96
	20	10.8	1.49	12.9	1.87	15.0	2.27	16.0	2.51	17.0	2.75	19.1	3.07	19.7	3.10
	21	10.8	1.52	12.9	1.91	15.0	2.35	16.0	2.59	17.0	2.85	19.1	3.14	19.5	3.17
	23	10.8	1.61	12.9	2.05	15.0	2.52	16.0	2.78	17.0	3.06	18.9	3.29	19.3	3.32
	25	10.8	1.72	12.9	2.18	15.0	2.70	16.0	2.98	17.0	3.27	18.6	3.43	19.0	3.46
	27	10.8	1.83	12.9	2.33	15.0	2.88	16.0	3.18	17.0	3.47	18.3	3.59	18.7	3.62
	29	10.8	1.95	12.9	2.48	15.0	3.08	16.0	3.40	17.0	3.68	18.1	3.74	18.5	3.77
	31	10.8	2.08	12.9	2.65	15.0	3.28	16.0	3.63	17.0	3.86	17.8	3.88	18.2	3.91
	33	10.8	2.21	12.9	2.82	15.0	3.50	16.0	3.87	17.0	4.01	17.5	4.03	17.9	4.06
	35	10.8	2.35	12.9	3.00	15.0	3.73	16.0	4.13	16.8	4.15	17.2	4.17	17.6	4.20
	37	10.8	2.44	12.9	3.13	15.0	3.84	16.0	4.20	16.5	4.22	17.0	4.24	17.4	4.28
	39	10.8	2.54	12.9	3.25	15.0	3.94	16.0	4.27	16.2	4.29	16.7	4.30	17.1	4.34
	41	10.4	2.88	12.4	3.70	14.4	4.42	15.2	4.75	15.4	4.77	15.4	4.79	16.3	4.83
	43	10.3	3.06	12.2	3.94	14.2	4.66	14.7	4.96	14.9	4.97	15.3	4.99	15.8	5.04
46	9.6	3.28	11.5	4.23	13.3	4.92	13.4	5.16	13.6	5.18	14.0	5.19	14.4	5.24	
48	8.5	2.83	10.1	3.66	11.5	4.20	11.7	4.38	11.8	4.39	12.2	4.40	12.5	4.44	
90	10	9.7	1.28	11.6	1.55	13.5	1.84	14.4	1.99	15.3	2.14	17.2	2.38	19.1	2.40
	12	9.7	1.32	11.6	1.62	13.5	1.90	14.4	2.04	15.3	2.21	17.2	2.51	19.1	2.53
	14	9.7	1.36	11.6	1.68	13.5	1.98	14.4	2.13	15.3	2.30	17.2	2.65	19.1	2.67
	16	9.7	1.40	11.6	1.74	13.5	2.07	14.4	2.23	15.3	2.42	17.2	2.78	19.1	2.81
	18	9.7	1.44	11.6	1.80	13.5	2.15	14.4	2.34	15.3	2.57	17.2	2.93	19.1	2.96
	20	9.7	1.49	11.6	1.87	13.5	2.27	14.4	2.51	15.3	2.75	17.2	3.07	19.1	3.10
	21	9.7	1.52	11.6	1.91	13.5	2.35	14.4	2.59	15.3	2.85	17.2	3.14	19.1	3.17
	23	9.7	1.61	11.6	2.05	13.5	2.52	14.4	2.78	15.3	3.06	17.2	3.29	18.8	3.32
	25	9.7	1.72	11.6	2.18	13.5	2.70	14.4	2.98	15.3	3.27	17.2	3.43	18.6	3.46
	27	9.7	1.83	11.6	2.33	13.5	2.88	14.4	3.18	15.3	3.47	17.2	3.59	18.3	3.62
	29	9.7	1.95	11.6	2.48	13.5	3.08	14.4	3.40	15.3	3.68	17.2	3.74	18.0	3.77
	31	9.7	2.08	11.6	2.65	13.5	3.28	14.4	3.63	15.3	3.86	17.2	3.88	17.7	3.91
	33	9.7	2.21	11.6	2.82	13.5	3.50	14.4	3.87	15.3	4.01	17.2	4.03	17.5	4.06
	35	9.7	2.35	11.6	3.00	13.5	3.73	14.4	4.13	15.3	4.15	16.9	4.17	17.2	4.20
	37	9.7	2.44	11.6	3.13	13.5	3.84	14.4	4.20	15.3	4.22	16.6	4.24	16.9	4.28
	39	9.7	2.54	11.6	3.25	13.5	3.94	14.4	4.27	15.3	4.29	16.4	4.30	16.6	4.34
	41	9.4	2.88	11.2	3.70	13.0	4.42	13.9	4.75	14.8	4.77	15.5	4.79	15.8	4.83
	43	9.2	3.06	11.0	3.94	12.8	4.66	13.7	4.96	14.6	4.97	15.0	4.99	15.3	5.04
46	8.7	3.28	10.3	4.23	12.0	4.92	12.8	5.16	13.2	5.18	13.7	5.19	14.0	5.24	
48	7.7	2.83	9.1	3.66	10.6	4.20	11.3	4.38	11.5	4.39	11.9	4.40	12.2	4.44	

7. Capacity Tables

Combination	Outdoor Air Temperature (°C DB)	Indoor Air Temperature (°C, DB/WB)													
		20.0 / 14.0		23.0 / 16.0		26.0 / 18.0		27.0 / 19.0		28.0 / 20.0		30.0 / 22.0		32.0 / 24.0	
		TC	PI	TC	PI	TC	PI	TC	PI	TC	PI	TC	PI	TC	PI
80	10	8.6	1.28	10.3	1.55	11.9	1.84	12.8	1.99	13.7	2.14	15.3	2.38	17.0	2.40
	12	8.6	1.32	10.3	1.62	11.9	1.90	12.8	2.04	13.7	2.21	15.3	2.51	17.0	2.53
	14	8.6	1.36	10.3	1.68	11.9	1.98	12.8	2.13	13.7	2.30	15.3	2.65	17.0	2.67
	16	8.6	1.40	10.3	1.74	11.9	2.07	12.8	2.23	13.7	2.42	15.3	2.78	17.0	2.81
	18	8.6	1.44	10.3	1.80	11.9	2.15	12.8	2.34	13.7	2.57	15.3	2.93	17.0	2.96
	20	8.6	1.49	10.3	1.87	11.9	2.27	12.8	2.51	13.7	2.75	15.3	3.07	17.0	3.10
	21	8.6	1.52	10.3	1.91	11.9	2.35	12.8	2.59	13.7	2.85	15.3	3.14	17.0	3.17
	23	8.6	1.61	10.3	2.05	11.9	2.52	12.8	2.78	13.7	3.06	15.3	3.29	17.0	3.32
	25	8.6	1.72	10.3	2.18	11.9	2.70	12.8	2.98	13.7	3.27	15.3	3.43	17.0	3.46
	27	8.6	1.83	10.3	2.33	11.9	2.88	12.8	3.18	13.7	3.47	15.3	3.59	17.0	3.62
	29	8.6	1.95	10.3	2.48	11.9	3.08	12.8	3.40	13.7	3.68	15.3	3.74	17.0	3.77
	31	8.6	2.08	10.3	2.65	11.9	3.28	12.8	3.63	13.7	3.86	15.3	3.88	17.0	3.91
	33	8.6	2.21	10.3	2.82	11.9	3.50	12.8	3.87	13.7	4.01	15.3	4.03	17.0	4.06
	35	8.6	2.35	10.3	3.00	11.9	3.73	12.8	4.13	13.7	4.15	15.3	4.17	16.8	4.20
	37	8.6	2.44	10.3	3.13	11.9	3.84	12.8	4.20	13.7	4.22	15.3	4.24	16.5	4.28
	39	8.6	2.54	10.3	3.25	11.9	3.94	12.8	4.27	13.7	4.29	15.3	4.30	16.2	4.34
	41	8.3	2.88	9.9	3.70	11.5	4.42	12.3	4.75	13.2	4.77	14.8	4.79	15.4	4.83
	43	8.2	3.06	9.8	3.94	11.3	4.66	12.2	4.96	13.0	4.97	14.6	4.99	14.9	5.04
46	7.7	3.28	9.2	4.23	10.6	4.92	11.4	5.16	12.2	5.18	13.3	5.19	13.6	5.24	
48	6.8	2.83	8.1	3.66	9.4	4.20	10.1	4.38	10.8	4.39	11.6	4.40	11.8	4.44	
70	10	7.5	1.28	9.0	1.55	10.5	1.84	11.2	1.99	11.9	2.14	13.4	2.38	14.9	2.40
	12	7.5	1.32	9.0	1.62	10.5	1.90	11.2	2.04	11.9	2.21	13.4	2.51	14.9	2.53
	14	7.5	1.36	9.0	1.68	10.5	1.98	11.2	2.13	11.9	2.30	13.4	2.65	14.9	2.67
	16	7.5	1.40	9.0	1.74	10.5	2.07	11.2	2.23	11.9	2.42	13.4	2.78	14.9	2.81
	18	7.5	1.44	9.0	1.80	10.5	2.15	11.2	2.34	11.9	2.54	13.4	2.89	14.9	2.96
	20	7.5	1.49	9.0	1.87	10.5	2.25	11.2	2.43	11.9	2.60	13.4	2.96	14.9	3.10
	21	7.5	1.52	9.0	1.91	10.5	2.27	11.2	2.45	11.9	2.62	13.4	3.01	14.9	3.17
	23	7.5	1.61	9.0	1.98	10.5	2.32	11.2	2.53	11.9	2.75	13.4	3.22	14.9	3.32
	25	7.5	1.68	9.0	2.05	10.5	2.47	11.2	2.71	11.9	2.94	13.4	3.43	14.9	3.46
	27	7.5	1.77	9.0	2.19	10.5	2.64	11.2	2.87	11.9	3.14	13.4	3.59	14.9	3.62
	29	7.5	1.89	9.0	2.32	10.5	2.80	11.2	3.06	11.9	3.34	13.4	3.74	14.9	3.77
	31	7.5	2.00	9.0	2.47	10.5	2.99	11.2	3.27	11.9	3.56	13.4	3.88	14.9	3.91
	33	7.5	2.12	9.0	2.61	10.5	3.18	11.2	3.47	11.9	3.78	13.4	4.03	14.9	4.06
	35	7.5	2.24	9.0	2.79	10.5	3.37	11.2	3.69	11.9	4.03	13.4	4.17	14.9	4.20
	37	7.5	2.38	9.0	2.95	10.5	3.59	11.2	3.93	11.9	4.22	13.4	4.24	14.9	4.28
	39	7.5	2.50	9.0	3.12	10.5	3.80	11.2	4.14	11.9	4.29	13.4	4.30	14.9	4.34
	41	7.3	2.88	8.7	3.59	10.1	4.38	10.8	4.75	11.5	4.77	12.9	4.79	14.3	4.83
	43	7.2	3.06	8.6	3.88	9.9	4.66	10.6	4.96	11.3	4.97	12.7	4.99	14.1	5.04
46	6.7	3.28	8.0	4.23	9.3	4.92	10.0	5.16	10.6	5.18	11.9	5.19	13.2	5.24	
48	5.9	2.83	7.1	3.66	8.2	4.20	8.8	4.38	9.4	4.39	10.5	4.40	11.7	4.44	
60	10	6.5	1.22	7.7	1.43	9.0	1.66	9.6	1.78	10.2	1.89	11.5	2.15	12.7	2.40
	12	6.5	1.24	7.7	1.45	9.0	1.68	9.6	1.81	10.2	1.93	11.5	2.18	12.7	2.45
	14	6.5	1.25	7.7	1.47	9.0	1.72	9.6	1.84	10.2	1.96	11.5	2.23	12.7	2.49
	16	6.5	1.27	7.7	1.51	9.0	1.74	9.6	1.87	10.2	2.01	11.5	2.27	12.7	2.54
	18	6.5	1.30	7.7	1.53	9.0	1.77	9.6	1.91	10.2	2.04	11.5	2.30	12.7	2.59
	20	6.5	1.32	7.7	1.55	9.0	1.81	9.6	1.94	10.2	2.07	11.5	2.35	12.7	2.65
	21	6.5	1.33	7.7	1.56	9.0	1.83	9.6	1.96	10.2	2.09	11.5	2.38	12.7	2.67
	23	6.5	1.35	7.7	1.60	9.0	1.85	9.6	1.99	10.2	2.14	11.5	2.47	12.7	2.84
	25	6.5	1.37	7.7	1.63	9.0	1.93	9.6	2.09	10.2	2.27	11.5	2.64	12.7	3.04
	27	6.5	1.42	7.7	1.72	9.0	2.05	9.6	2.23	10.2	2.42	11.5	2.80	12.7	3.24
	29	6.5	1.51	7.7	1.83	9.0	2.18	9.6	2.37	10.2	2.57	11.5	2.99	12.7	3.46

7. Capacity Tables

Combination	Outdoor Air Temperature (°C DB)	Indoor Air Temperature (°C, DB/WB)													
		20.0 / 14.0		23.0 / 16.0		26.0 / 18.0		27.0 / 19.0		28.0 / 20.0		30.0 / 22.0		32.0 / 24.0	
		TC	PI	TC	PI	TC	PI	TC	PI	TC	PI	TC	PI	TC	PI
60	31	6.5	1.60	7.7	1.94	9.0	2.32	9.6	2.53	10.2	2.74	11.5	3.19	12.7	3.68
	33	6.5	1.68	7.7	2.05	9.0	2.46	9.6	2.68	10.2	2.91	11.5	3.39	12.7	3.92
	35	6.5	1.78	7.7	2.18	9.0	2.61	9.6	2.85	10.2	3.09	11.5	3.61	12.7	4.17
	37	6.5	1.88	7.7	2.30	9.0	2.77	9.6	3.02	10.2	3.28	11.5	3.83	12.7	4.28
	39	6.5	1.98	7.7	2.43	9.0	2.93	9.6	3.21	10.2	3.46	11.5	4.07	12.7	4.34
	41	6.2	2.26	7.4	2.80	8.7	3.38	9.3	3.69	9.9	3.99	11.1	4.70	12.3	4.83
	43	6.1	2.43	7.3	3.01	8.5	3.65	9.1	3.98	9.7	4.31	10.9	4.99	12.1	5.04
	46	5.8	2.64	6.9	3.28	8.0	3.98	8.5	4.34	9.1	4.70	10.2	5.19	11.3	5.24
50	48	5.1	2.30	6.1	2.86	7.1	3.48	7.6	3.79	8.1	4.11	9.0	4.40	10.0	4.44
	10	5.4	0.99	6.5	1.15	7.5	1.31	8.0	1.40	8.5	1.48	9.5	1.67	10.6	1.86
	12	5.4	1.00	6.5	1.16	7.5	1.33	8.0	1.42	8.5	1.51	9.5	1.70	10.6	1.89
	14	5.4	1.01	6.5	1.18	7.5	1.35	8.0	1.44	8.5	1.53	9.5	1.72	10.6	1.92
	16	5.4	1.03	6.5	1.20	7.5	1.37	8.0	1.47	8.5	1.56	9.5	1.75	10.6	1.95
	18	5.4	1.04	6.5	1.21	7.5	1.39	8.0	1.49	8.5	1.59	9.5	1.79	10.6	1.99
	20	5.4	1.05	6.5	1.23	7.5	1.42	8.0	1.51	8.5	1.62	9.5	1.82	10.6	2.04
	21	5.4	1.07	6.5	1.24	7.5	1.43	8.0	1.53	8.5	1.63	9.5	1.84	10.6	2.06
	23	5.4	1.09	6.5	1.26	7.5	1.45	8.0	1.56	8.5	1.66	9.5	1.87	10.6	2.10
	25	5.4	1.10	6.5	1.28	7.5	1.48	8.0	1.59	8.5	1.71	9.5	1.96	10.6	2.24
	27	5.4	1.12	6.5	1.33	7.5	1.57	8.0	1.69	8.5	1.82	9.5	2.10	10.6	2.39
	29	5.4	1.18	6.5	1.41	7.5	1.66	8.0	1.80	8.5	1.93	9.5	2.22	10.6	2.54
	31	5.4	1.24	6.5	1.49	7.5	1.76	8.0	1.90	8.5	2.06	9.5	2.37	10.6	2.70
	33	5.4	1.32	6.5	1.58	7.5	1.87	8.0	2.02	8.5	2.18	9.5	2.52	10.6	2.88
	35	5.4	1.39	6.5	1.67	7.5	1.97	8.0	2.14	8.5	2.31	9.5	2.66	10.6	3.06
	37	5.4	1.47	6.5	1.76	7.5	2.09	8.0	2.27	8.5	2.44	9.5	2.84	10.6	3.25
39	5.4	1.54	6.5	1.85	7.5	2.22	8.0	2.39	8.5	2.57	9.5	3.00	10.6	3.44	
41	5.2	1.77	6.2	2.13	7.2	2.55	7.7	2.75	8.2	2.96	9.2	3.45	10.3	3.97	
43	5.1	1.90	6.1	2.30	7.1	2.74	7.6	2.97	8.1	3.19	9.1	3.73	10.1	4.28	
46	4.8	2.07	5.8	2.50	6.7	2.99	7.1	3.23	7.6	3.47	8.5	4.07	9.5	4.68	
48	4.3	1.80	5.1	2.18	5.9	2.60	6.3	2.82	6.7	3.03	7.5	3.56	8.4	4.09	

Note

- TC: Total Capacity(kW), PI : Power Input(kW, Comp. + Outdoor fan motor)
- Capacity tables show the average value of conditions which may occur.

8. Capacity Correction Factor

8.1 Cooling Operation

ARUV030GSD6 [ARUV030GSD6], ARUV040GSD6 [ARUV040GSD6]
ARUV050GSD6 [ARUV050GSD6], ARUV060GSD6 [ARUV060GSD6]

Level difference (=IDU-ODU) (m)	Capacity correction factor (%) by equivalent pipe length (m)																							
	7.5	10	20	30	40	50	60	70	80	90	100	110	120	130	140	150	160	170	180	190	200	210	220	225
-15	-	-	-	-	-	-	-	-	-	-	-	-	-	-	-	-	-	-	-	-	-	-	-	-
-10	-	99.0	97.0	93.0	91.0	90.0	-	-	-	-	-	-	-	-	-	-	-	-	-	-	-	-	-	-
-7.5	100.0	99.0	97.0	93.0	91.0	90.0	-	-	-	-	-	-	-	-	-	-	-	-	-	-	-	-	-	-
0	100.0	100.0	97.0	93.0	91.0	90.0	-	-	-	-	-	-	-	-	-	-	-	-	-	-	-	-	-	-
7.5	100.0	100.0	98.0	93.0	92.0	90.0	-	-	-	-	-	-	-	-	-	-	-	-	-	-	-	-	-	-
10	-	100.0	98.0	94.0	92.0	90.0	-	-	-	-	-	-	-	-	-	-	-	-	-	-	-	-	-	-
15	-	-	-	-	-	-	-	-	-	-	-	-	-	-	-	-	-	-	-	-	-	-	-	-

Note

- These figures indicate the rate of change in capacity of a standard indoor unit system at maximum load under standard conditions. (Moreover, under partial load conditions there is only a minor deviation from the rate of change in capacity shown in the above figures.)
- With this outdoor(outside) unit, evaporating pressure constant control when cooling, and condensing pressure constant control when heating is carried out.
- If heat insulation of piping is insufficient, heat loss will become larger and capacity will decrease.
- Method of calculating cooling capacity = maximum cooling capacity of outdoor(outside)units
= cooling / heating capacity of outdoor(outside) units obtained from capacity table x capacity correction factor due to piping length to the farthest indoor unit.
- Equivalent piping length for Y Branch and other pipes can be calculated with following table.

Piping Diameter [mm(inch)]	Ø6.35 (1/4)	Ø9.52 (3/8)	Ø12.7 (1/2)	Ø15.88 (5/8)	Ø19.05 (3/4)	Ø22.2 (7/8)	Ø25.4 (1)	Ø28.58 (1-1/8)	Ø31.8 (1-1/4)	Ø34.9 (1-3/8)	Ø38.1 (1-1/2)	Ø41.3 (1-5/8)	Ø44.5 (1-3/4)	Ø53.98 (2-1/8)
Elbow(m)	0.16	0.18	0.20	0.25	0.35	0.40	0.45	0.50	0.55	0.60	0.65	0.70	0.75	0.85
Y Branch(m)	0.50													
Header(m)	1.00													
HR unit(m)	0.25													

- When the any one (or both) of below conditions are satisfied, the diameter of main pipe must be increased.
 - The equivalent length between outdoor(outside) unit and the farthest indoor unit is 90m or more (Liquid or Gas pipes are increased in accordance with below table)
 - The level difference (outdoor(outside) unit <-> Indoor unit) is 50m or more (Only liquid pipe is increased)
 Refer to the table (Refrigerant pipe diameter from outdoor(outside) unit to first branch.) in the 'installation of outdoor(outside) units' part.
- Read cooling capacity rate of change in the above figures based on the following equivalent length.
Overall equivalent length = (equivalent length of main pipe) x correction factor + (equivalent length after first branching)

Rate of Change (object piping)	Correction factor			
	standard size	size increase		
		Capacity Class ≤ 34HP	Capacity Class ≤ 60HP	Capacity Class ≥ 62HP
Cooling(Gas pipe)	1	0.5	0.5	-

※ Accordance with product type(operation mode), target region, model line up could be different.
Apply the correction factor after selecting that according to the unit capacity.

■ Calculation Example for overall equivalent length

* Installation condition : Correction factor = 0.5, Main pipe length = 30m, Branch pipe length = 30m, HU=0m

(Correction factor depends on 'Model's Capacity Class'. Refer to upper table. Maximum pipe length and limit condition will be different each model. Use this example only for reference.)

: Overall equivalent pipe length for Cooling = 30m x 0.5 + 30m = 45m

* The rate of change in

Read the correction factor value condition on length = 45m and HU = 0 in Cooling correction factor table.

9. Operation Limits

9.1 Cooling Operation

ARUV030GSD6 [ARUV030GSD6], ARUV040GSD6 [ARUV040GSD6], ARUV050GSD6 [ARUV050GSD6], ARUV060GSD6 [ARUV060GSD6]

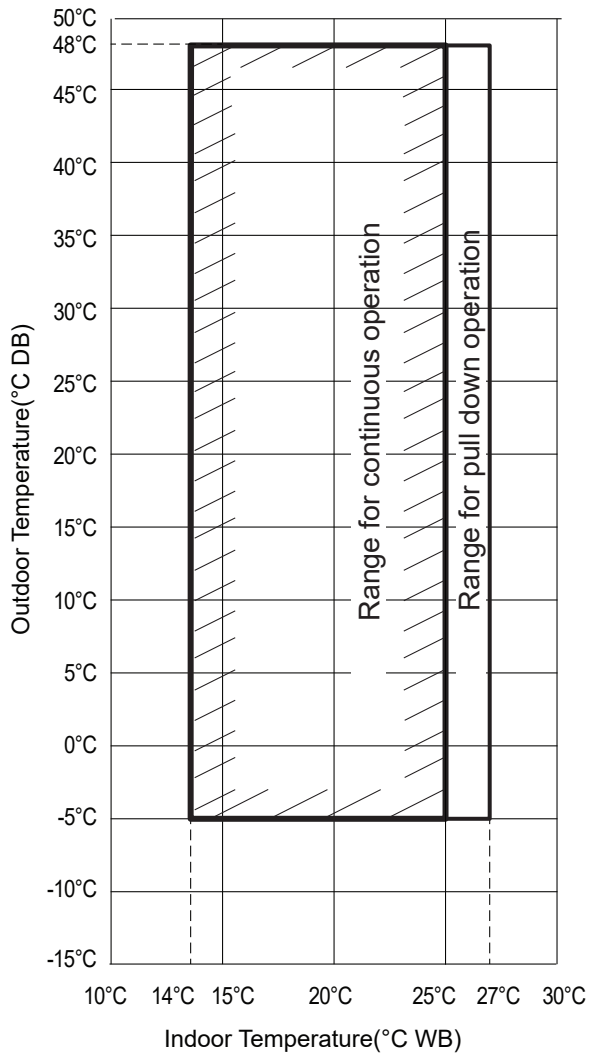

Note

- These figures assume the following operating conditions
 - : Equivalent piping length is standard condition, and level difference is 0m.
- Range of pull down operation: If the relative humidity is too high, cooling capacity can be decreased by the sensible heat reduction.
- Warming up operation means that the outdoor(outside) unit operates to reach the range of continuous operating, however it may not operate continuously due to safety or protection logic.

10. Sound Levels

10.1 Pressure Levels

ARUV030GSD6 [ARUV030GSD6]

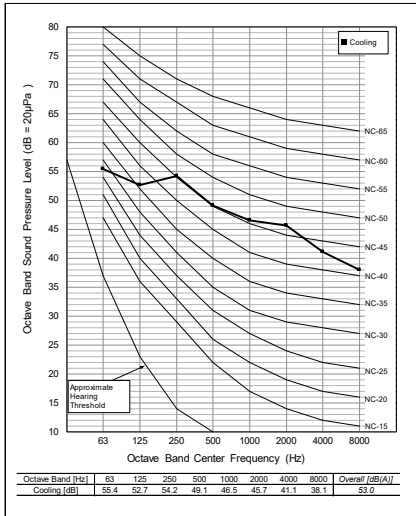

Sound level [dB(A), @ Standard condition]

Cooling / Heating

53.0 / -

Note

- Data is valid at diffuse field condition.
- Data is valid at nominal operating condition. Refer to the model specifications for nominal conditions.(Power source and Ambient temperature, etc)
- Reference acoustic pressure 0dB = 20µPa.
- Sound levels can be increased in accordance with installation and operating conditions. (Operating conditions include some functional condition like Static pressure mode, air guide use, Room target temperature setting, etc and these functions are different in accordance with each model.)
- Sound level will vary depending on a range of factors such as the construction(acoustic absorption coefficient) of particular room in which the equipment is installed.
- Sound pressure level is measured on the rated condition in the anechoic rooms by ISO 3745 Standard. Therefore, these values can be increased owing to ambient conditions during operation.

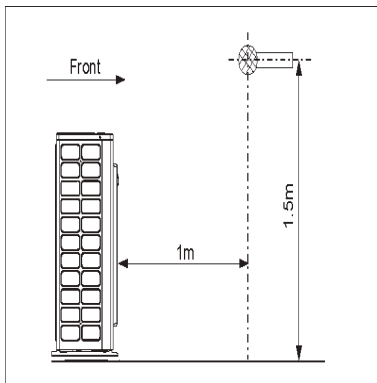

10. Sound Levels

ARUV040GSD6 [ARUV040GSD6]

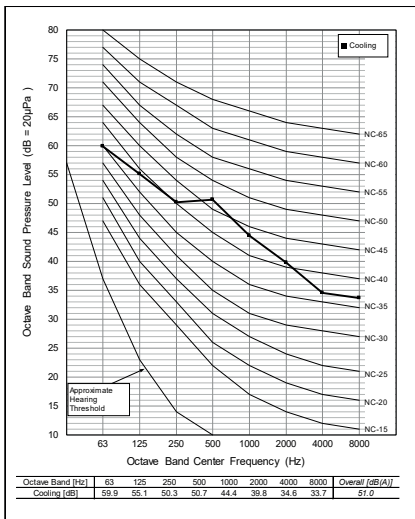

Sound level [dB(A), @ Standard condition]	
Cooling / Heating	52.0 / -

Note

- Data is valid at diffuse field condition.
- Data is valid at nominal operating condition. Refer to the model specifications for nominal conditions.(Power source and Ambient temperature, etc)
- Reference accoustic pressure 0dB = 20µPa.
- Sound levels can be increased in accordance with installation and operating conditions. (Operating conditions include some functional condition like Static pressure mode, air guide use, Room target temperature setting, etc and these functions are different in accordance with each model.)
- Sound level will vary depending on a range of factors such as the construction(acoustic absorption coefficient) of particular room in which the equipment is installed.
- Sound pressure level is measured on the rated condition in the anechoic rooms by ISO 3745 Standard. Therefore, these values can be increased owing to ambient conditions during operation.

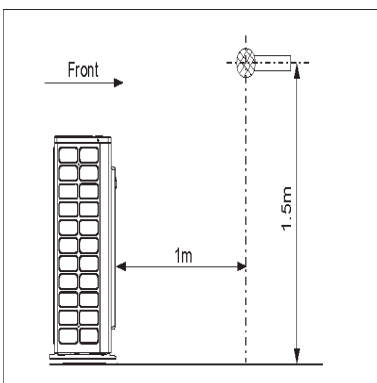

10. Sound Levels

ARUV050GSD6 [ARUV050GSD6]

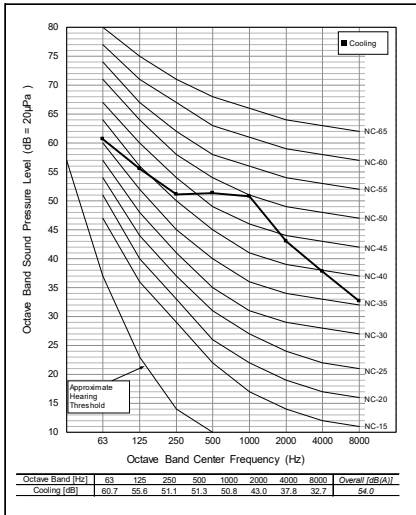

Sound level [dB(A), @ Standard condition]	
Cooling / Heating	54.0 / -

Note

- Data is valid at diffuse field condition.
- Data is valid at nominal operating condition. Refer to the model specifications for nominal conditions.(Power source and Ambient temperature, etc)
- Reference acoustic pressure 0dB = 20μPa.
- Sound levels can be increased in accordance with installation and operating conditions. (Operating conditions include some functional condition like Static pressure mode, air guide use, Room target temperature setting, etc and these functions are different in accordance with each model.)
- Sound level will vary depending on a range of factors such as the construction(acoustic absorption coefficient) of particular room in which the equipment is installed.
- Sound pressure level is measured on the rated condition in the anechoic rooms by ISO 3745 Standard. Therefore, these values can be increased owing to ambient conditions during operation.

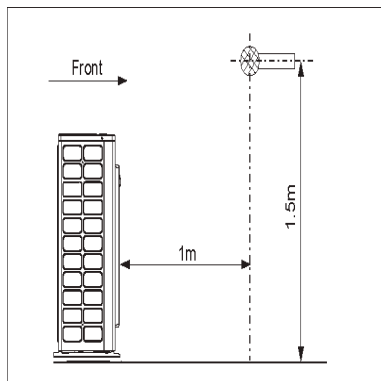

10. Sound Levels

ARUV060GSD6 [ARUV060GSD6]

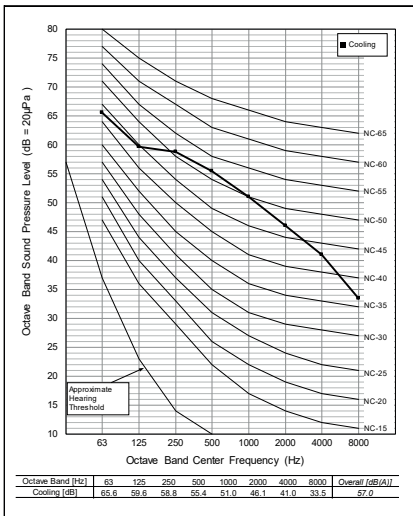

Sound level [dB(A), @ Standard condition]	
Cooling / Heating	57.0 / -

Note

- Data is valid at diffuse field condition.
- Data is valid at nominal operating condition. Refer to the model specifications for nominal conditions.(Power source and Ambient temperature, etc)
- Reference acoustic pressure 0dB = 20μPa.
- Sound levels can be increased in accordance with installation and operating conditions. (Operating conditions include some functional condition like Static pressure mode, air guide use, Room target temperature setting, etc and these functions are different in accordance with each model.)
- Sound level will vary depending on a range of factors such as the construction(acoustic absorption coefficient) of particular room in which the equipment is installed.
- Sound pressure level is measured on the rated condition in the anechoic rooms by ISO 3745 Standard. Therefore, these values can be increased owing to ambient conditions during operation.

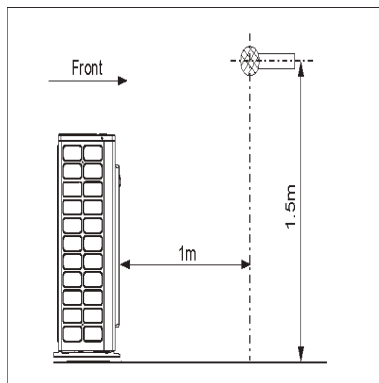

Installation of Outdoor Units

- 1. Alternative Refrigerant R410A**
- 2. Select the Best Location**
- 3. Installation Space**
- 4. Lifting Method**
- 5. Installation**
- 6. Refrigerant Piping Installation**
- 7. Refrigerant Piping System**
- 8. Electrical Wiring**

1. Alternative Refrigerant R410A

- The refrigerant R410A has the property of higher operating pressure in comparison with R22. Therefore, all materials have the characteristics of higher resisting pressure than R22 ones and this characteristic should be also considered during the installation.
R410A is an azeotrope of R32 and R125 mixed at 50:50, so the ozone depletion potential (ODP) of R410A is 0.
-

CAUTION

- The wall thickness of the piping should comply with the relevant local and national regulations for the designed pressure 3.8MPa
 - Since R410A is a mixed refrigerant, the required additional refrigerant must be charged in its liquid state. If the refrigerant is charged in its gaseous state, its composition changes and the system will not work properly.
 - Do not place the refrigerant container under the direct rays of the sun to prevent it from exploding.
 - For high-pressure refrigerant, any unapproved pipe must not be used.
 - Do not heat pipes more than necessary to prevent them from softening.
 - Be careful not to install wrongly to minimize economic loss because it is expensive in comparison with R22.
-

2. Select the Best Location

1. Select space for installing outdoor unit, which will meet the following conditions:
 - No direct thermal radiation from other heat sources
 - No possibility of annoying neighbors by noise from unit
 - No exposition to strong wind
 - With strength which bears weight of unit
 - Note that drain flows out of unit when heating
 - With space for air passage and service work shown next
 - Because of the possibility of fire, do not install unit to the space where generation, inflow, stagnation, and leakage of combustible gas is expected.
 - Avoid unit installation in a place where acidic solution and spray (sulfur) are often used.
 - Do not use unit under any special environment where oil, steam and sulfuric gas exist.
 - It is recommended to fence round the outdoor unit in order to prevent any person or animal from accessing the outdoor unit.
 - If installation site is area of heavy snowfall, then the following directions should be observed.
 - Make the foundation as high as possible.
 - Fit a snow protection hood.
2. Select installation location considering following conditions to avoid bad condition when additionally performing defrost operation.
 - Install the outdoor unit at a place well ventilated and having a lot of sunshine in case of installing the product at a place with a high humidity in winter (near beach, coast, lake, etc).
(Ex) Rooftop where sunshine always shines.
 - Performance of heating will be reduced and pre-heat time of the indoor unit may be lengthened in case of installing the outdoor unit in winter at following location:
 - Shade position with a narrow space
 - Location with much moisture in neighboring floor.
 - Location with much humidity around.
 - Location where ventilation is good.
It is recommended to install the outdoor unit at a place with a lot of sunshine as possible as.
 - Location where water gathers since the floor is not even.
3. When installing the outdoor unit in a place that is constantly exposed to a strong wind like a coast or on a high story of a building, secure a normal fan operation by using a duct or a wind shield.
 - Install the unit so that its discharge port faces to the wall of the building.
Keep a distance 500mm or more between the unit and the wall surface.
 - Supposing the wind direction during the operation season of the air conditioner, install the unit so that the discharge port is set at right angle to the wind direction.

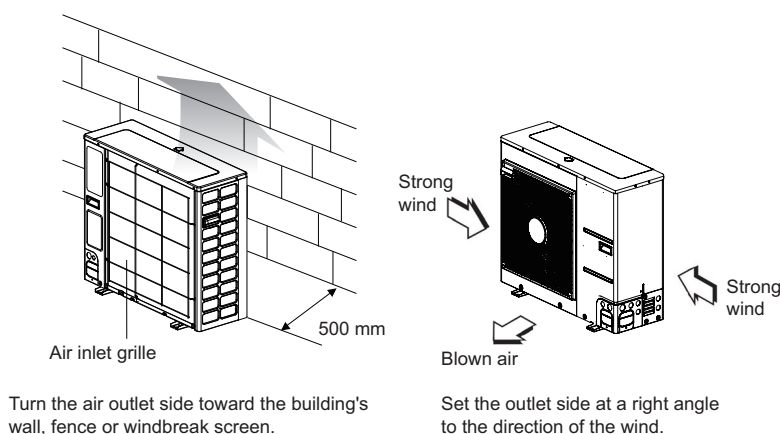

※ Outdoor unit is representative. Actual appearance of outdoor unit may be different but clearances will stay the same.

2. Select the Best Location

◆ Seasonal wind and cautions in winter

- Sufficient measures are required in a snow area or severe cold area in winter so that product can be operated well.
- Get ready for seasonal wind or snow in winter even in other areas.
- Install a suction and discharge duct not to let in snow or rain.
- Install the outdoor unit not to come in contact with snow directly. If snow piles up and freezes on the air suction hole, the system may malfunction. If it is installed at snowy area, attach the hood to the system.
- The raised support platform must be high enough to allow the unit to remain above possible snow drifts, and must be higher than the maximum anticipated snowfall for the location

Note

1. Don't install the suction hole and discharge hole of the Outdoor unit facing the seasonal wind.
-

3. Installation Space

- The following values are the least space for installation.
If any service area is needed for service according to field circumstance, obtain enough service space.
- The unit of values is mm.

3.1 Individual Installation

■ In case of obstacles on the suction side

1. Stand alone installation

[Unit:mm]

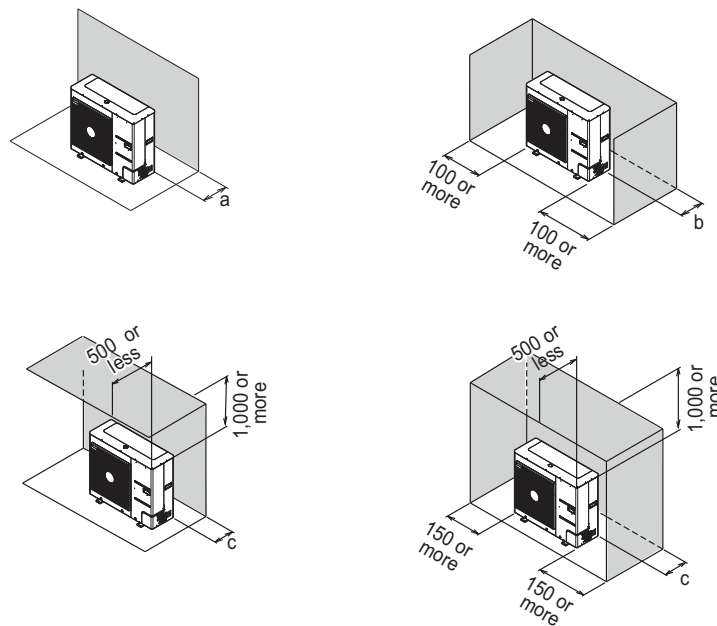

2. Collective installation

[Unit:mm]

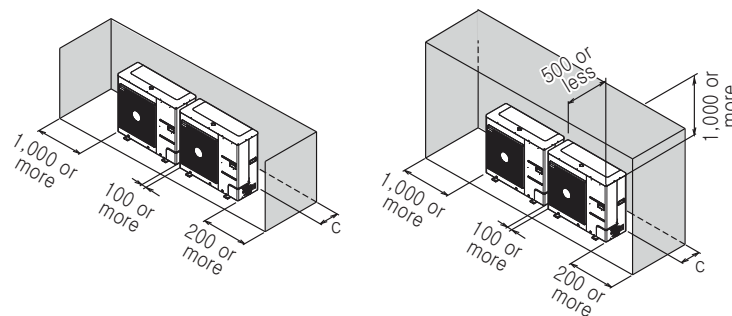

Chassis code	U24A U36A Chassis
a	100 or more
b	100 or more
c	300 or more

Note

- Depending on the sales region or product type, external appearance and applicability of each “Chassis” might be varied.

3. Installation Space

■ In case of obstacles on the discharge side

1. Stand alone installation

[Unit:mm]

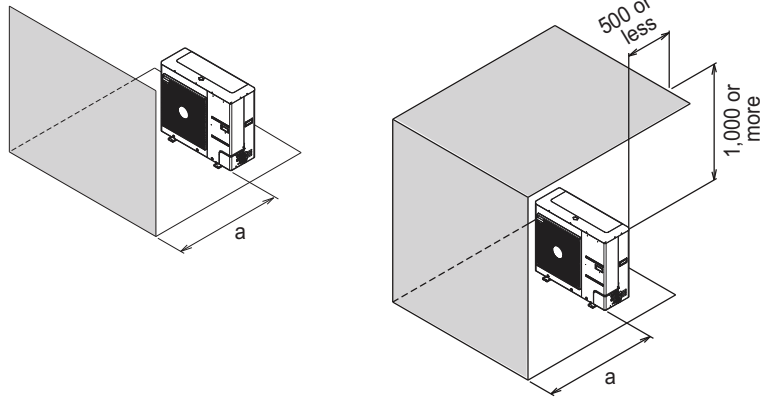

2. Collective installation

[Unit:mm]

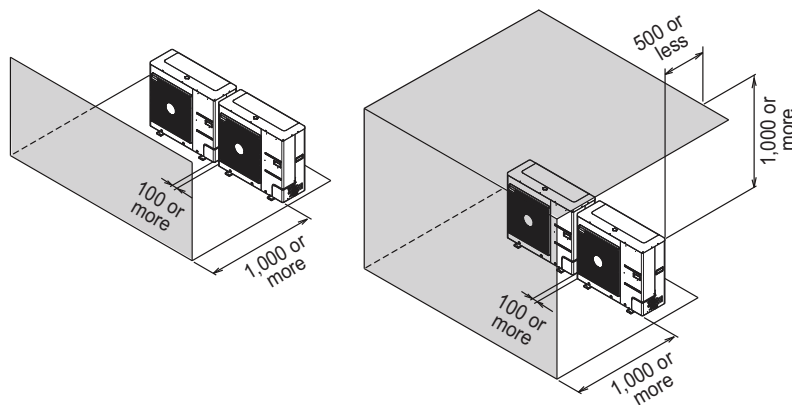

Chassis code	U24A U36A Chassis
a	500 or more
Note	
• Depending on the sales region or product type, external appearance and applicability of each “Chassis” might be varied.	

3. Installation Space

■ In case of obstacles on the suction and the discharge side

- Obstacle height of discharge side is higher than the unit

1. Stand alone installation

[Unit:mm]

L > H

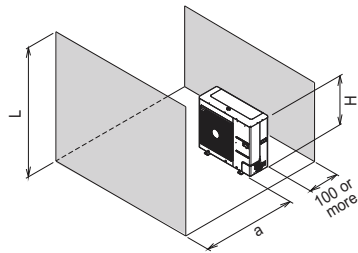

L > H

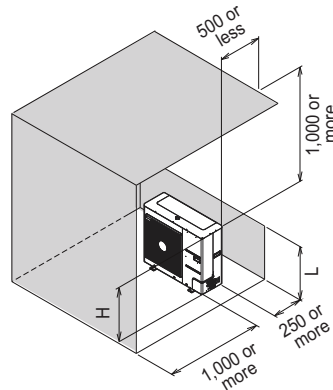

2. Collective installation

[Unit:mm]

L > H

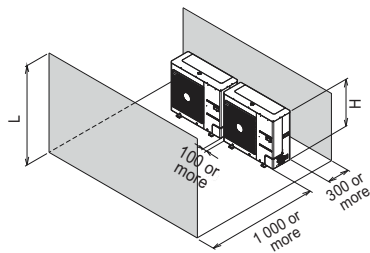

L > H

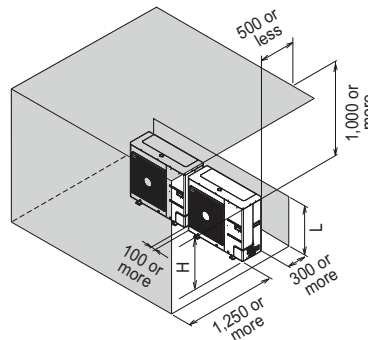

Chassis code	U24A U36A Chassis
a	500 or more
Note	
• Depending on the sales region or product type, external appearance and applicability of each "Chassis" might be varied.	

3. Installation Space

- Obstacle height of discharge side is lower than the unit

1. Stand alone installation

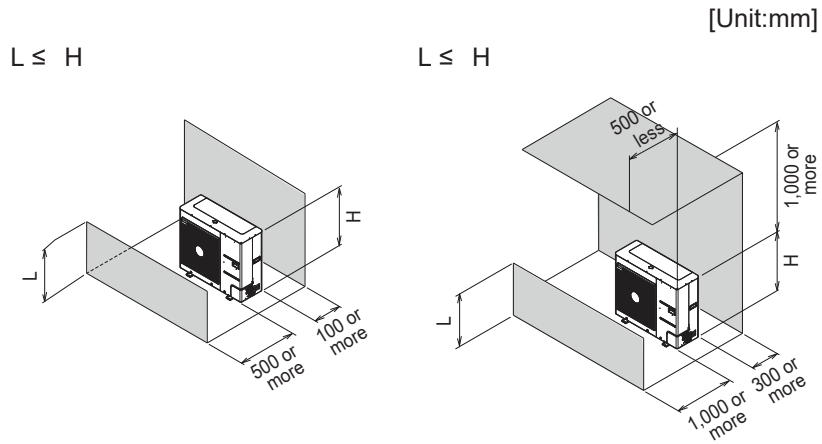

2. Collective installation

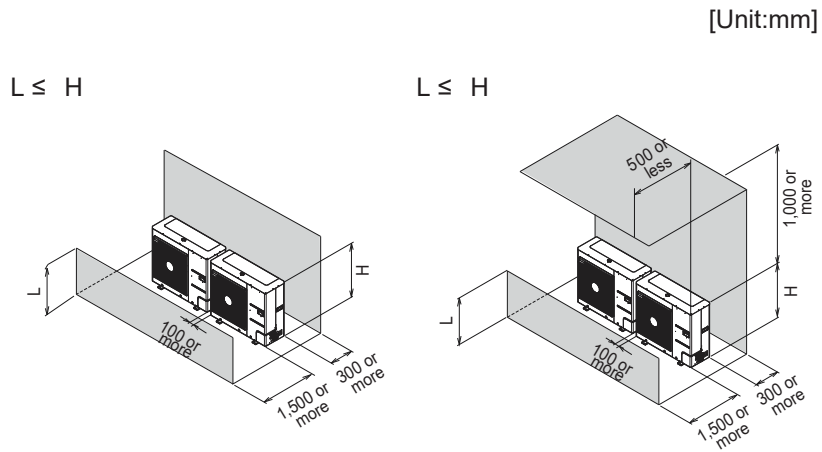

3. Installation Space

3.2 Collective / continuous installation

Space required for collective installation and continuous installation: When installing several units, leave space between each block as shown below considering passage for air and people.

■ One row of stand alone installation

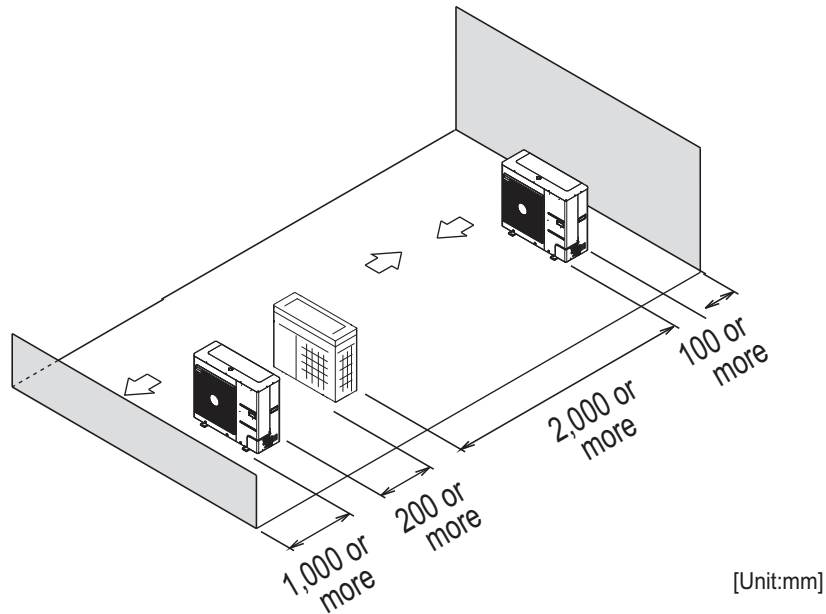

■ Rows of collective installation (2 or more)

- L should be smaller than H

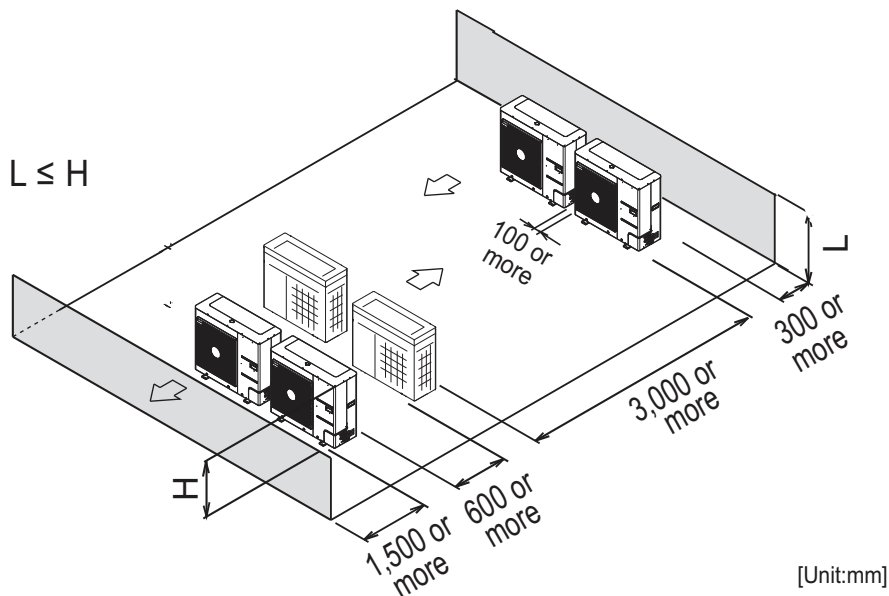

4. Lifting Method

- When carrying the suspended, unit pass the ropes between legs of base panel under the unit.
- Always lift the unit with ropes attached at four points so that impact is not applied to the unit.
- Attach the ropes to the unit at an angle of 40° or less.
- Use only accessories and parts which are of the designated specification when installing.

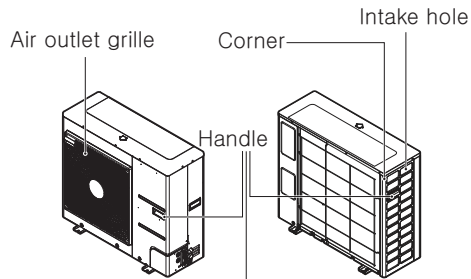

Always hold the unit by the corners, as holding it by the side intake holes on the casing may cause them to deform.

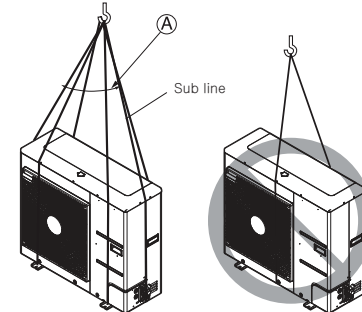

Ⓐ 40° or less

⚠ WARNING

⚠ CAUTION

Be very careful while carrying the product.

- Do not have only one person carry product if it is more than 20 kg.
- PP bands are used to pack some products. Do not use them as a mean for transportation because they are dangerous.
- Do not touch heat exchanger fins with your bare hands. Otherwise you may get a cut in your hands.
- Tear plastic packaging bag and scrap it so that children cannot play with it Otherwise plastic packaging bag may suffocate children to death.
- When carrying in Outdoor unit, be sure to support it at four points. Carrying in and lifting with 3-point support may make Outdoor unit unstable, resulting in a fall.

5. Refrigerant Piping Installation

5.1 Precautions on Pipe connection / Valve operation

Pipe connection is done by connecting from the end of the pipe to the branching pipes, and the refrigerant pipe coming out of the outdoor unit is divided at the end to connect to each indoor unit. Flare connection for the indoor unit, and welding connection for the outdoor pipe and the branching parts.

- Use hexagonal wrench to open/close the valve.

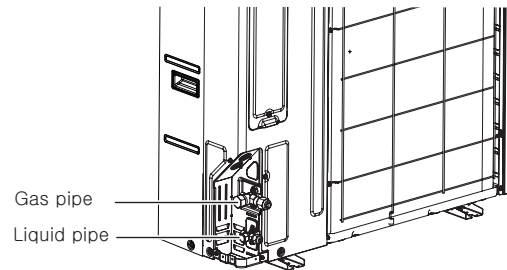

⚠ WARNING

- Always careful not to leak the refrigerant during welding.
- The refrigerant generates poisonous gas harmful to human body if combusted.
- Do not perform welding in a closed space.
- Be sure to close the cap of the service port to prevent gas leakage after the work.

⚠ CAUTION

Please block the pipe knock outs of the front and side panels after installing the pipes.
(Animals or foreign objects may be brought in to damage wires.)

6. Refrigerant Piping System

6.1 Pipe Connection Method between outdoor unit / indoor unit

6.1.1 Selection of Refrigerant Piping

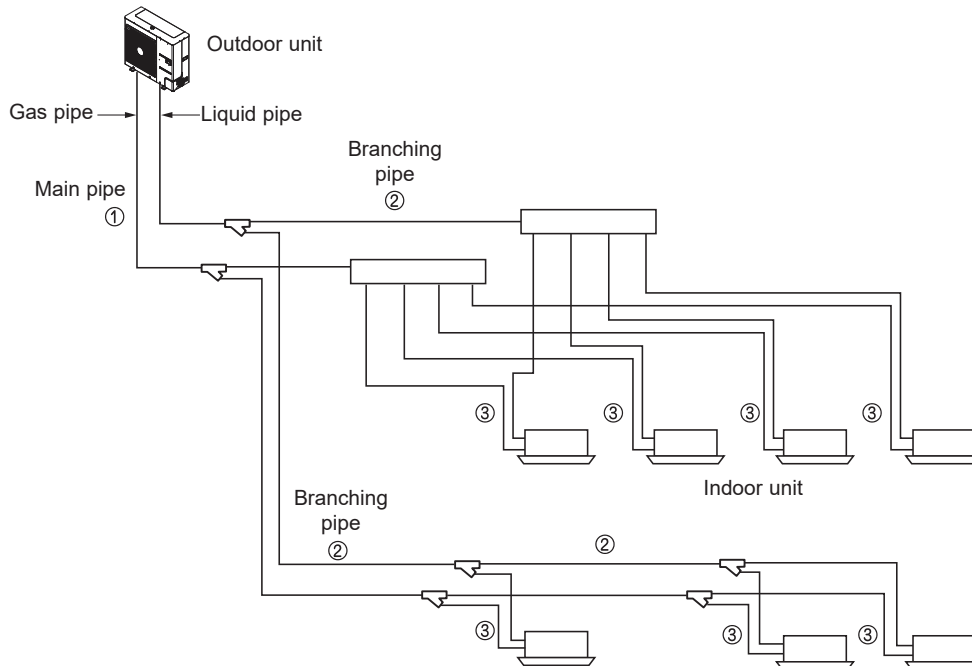

■ Selection of Pipe Size

① Main Pipe(A) : Outdoor Unit → 1st Branching Section

Upward Outdoor unit total capacity	Standard Pipe Diameter	
	Liquid pipe [mm(inch)]	Gas pipe [mm(inch)]
HP		
3	Ø 9.52(3/8)	Ø 15.88(5/8)
4	Ø 9.52(3/8)	Ø 15.88(5/8)
5	Ø 9.52(3/8)	Ø 15.88(5/8)
6	Ø 9.52(3/8)	Ø 19.05(3/4)

② Branching Pipe (B,C,D) : Branching Section → Branching Section

Downward Indoor Unit total capacity [kW(Btu/h)]	Liquid pipe [mm(inch)]	Gas pipe [mm(inch)]
≤ 5.6(19,100)	Ø6.35(1/4)	Ø12.7(1/2)
< 16.0(54,600)	Ø9.52(3/8)	Ø15.88(5/8)
< 22.4(76,400)	Ø9.52(3/8)	Ø19.05(3/4)
< 36.4(124,200)	Ø9.52(3/8)	Ø22.2(7/8)

③ Indoor Unit Connecting Pipe (Branching Section → Indoor Unit)

Indoor Unit capacity [kW(Btu/h)]	Liquid pipe [mm(inch)]	Gas pipe [mm(inch)]
≤ 5.6(19,100)	Ø6.35(1/4)	Ø12.7(1/2)
< 16.0(54,600)	Ø9.52(3/8)	Ø15.88(5/8)
≤ 22.4(76,400)	Ø9.52(3/8)	Ø19.05(3/4)
≤ 28.0(95,900)	Ø9.52(3/8)	Ø22.2(7/8)

⚠ CAUTION

- Bending radius should be at least twice the diameter of the pipe.
- Bend pipe after 500mm or more from branch(or header). Do not bend U type. It may cause Performance unsatisfactory or noise.

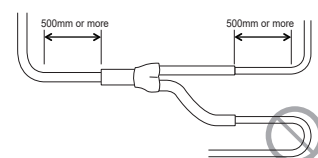

6. Refrigerant Piping System

6.1.2 Model (ARUV***GSD6)

Y branch method

- Ⓐ: Outdoor Unit
- Ⓑ: 1st branch (Y branch)
- Ⓓ: Indoor Units

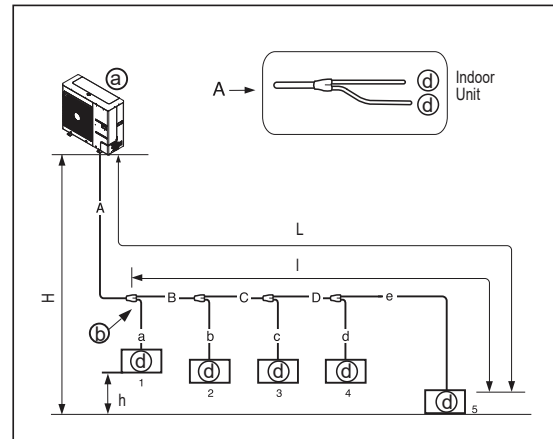

⚠ WARNING

- Depending on the sales region or product type, external appearance and applicability of each “Chassis” might be varied.

Connection method		Y branch only		
		3 HP	4 HP	5 / 6 HP
Max. pipe length	Longest pipe length (L) : between Outdoor Unit ↔ Indoor Unit	$A+B+C+D+e \leq 30\text{m}$	$A+B+C+D+e \leq 50\text{m}$	$A+B+C+D+e \leq 50\text{m}$
	Longest pipe length after 1st branch (ℓ)	20 m	30 m	30 m
	Total pipe length	50 m	85 m	100 m
Max. difference in height	Difference in height (H) : between Outdoor Unit ↔ Indoor Unit	15 m	15 m	15 m
	Difference in height (h) : between Indoor Unit ↔ Indoor Unit	7.5 m	7.5 m	7.5 m

6. Refrigerant Piping System

Combination of Y branch / header method

- Ⓐ: Outdoor Unit
- Ⓑ: 1st branch (Y branch)
- Ⓒ: Y branch
- Ⓓ: Indoor Units
- Ⓔ: Header
- Ⓕ: Sealed piping

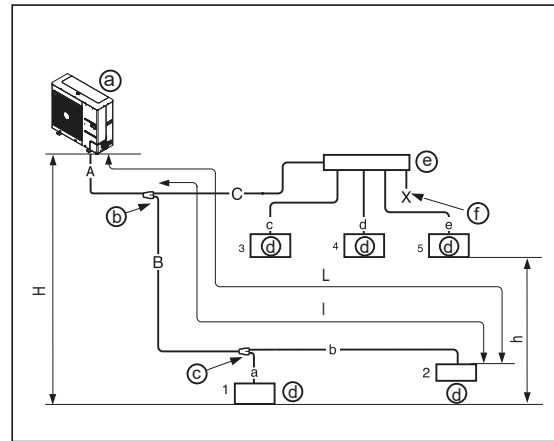

⚠ WARNING

- Depending on the sales region or product type, external appearance and applicability of each “Chassis” might be varied.
- Branch pipe can not be used after header.
- Pipe length after header branching
 - It is recommended that difference in length of the pipes connected to the indoor units (a~f) is minimized. Performance difference between indoor units may occur.
 - Indoor units should be installed at lower position than the header.

Connection method		Combination of Y branch / header		
		3 HP	4 HP	5 / 6 HP
Max. pipe length	Longest pipe length (L) : between Outdoor Unit ↔ Indoor Unit	$A+B+b \leq 30\text{m}$	$A+B+b \leq 50\text{m}$	$A+B+b \leq 50\text{m}$
	Longest pipe length after 1st branch (l)	20 m	30 m	30 m
	Total pipe length	50 m	85 m	100 m
Max. difference in height	Difference in height (H) : between Outdoor Unit ↔ Indoor Unit	15 m	15 m	15 m
	Difference in height (h) : between Indoor Unit ↔ Indoor Unit	7.5 m	7.5 m	7.5 m

6. Refrigerant Piping System

Header method

- Ⓐ: Outdoor Unit
- Ⓓ: Indoor Units
- Ⓔ: Header
- Ⓕ: Sealed piping

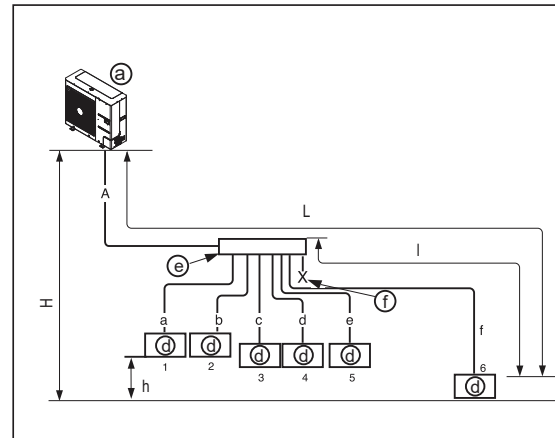

⚠ WARNING

- Depending on the sales region or product type, external appearance and applicability of each “Chassis” might be varied.
- Branch pipe can not be used after header.
- Pipe length after header branching
 - It is recommended that difference in length of the pipes connected to the indoor units (a~f) is minimized. Performance difference between indoor units may occur.
 - Indoor units should be installed at lower position than the header.

Connection method		Header only		
		3 HP	4 HP	5 / 6 HP
Max. pipe length	Longest pipe length (L) : between Outdoor Unit ↔ Indoor Unit	$A+f \leq 30\text{m}$	$A+f \leq 50\text{m}$	$A+f \leq 50\text{m}$
	Longest pipe length after 1st branch (ℓ)	20 m	30 m	30 m
	Total pipe length	50 m	85 m	100 m
Max. difference in height	Difference in height (H) : between Outdoor Unit ↔ Indoor Unit	15 m	15 m	15 m
	Difference in height (h) : between Indoor Unit ↔ Indoor Unit	7.5 m	7.5 m	7.5 m

6. Refrigerant Piping System

6.2 The amount of Refrigerant

The calculation of the additional charge should take into account the length of pipe and CF(Correction Factor) value of indoor unit.

Additional charge(kg)	=	Total liquid pipe : Ø25.4 mm	×	0.480(kg/m)
	+	Total liquid pipe : Ø22.2 mm	×	0.354(kg/m)
	+	Total liquid pipe : Ø19.05 mm	×	0.266(kg/m)
	+	Total liquid pipe : Ø15.88 mm	×	0.173(kg/m)
	+	Total liquid pipe : Ø12.7 mm	×	0.118(kg/m)
	+	Total liquid pipe : Ø9.52 mm	×	0.061(kg/m)
	+	Total liquid pipe : Ø6.35 mm	×	0.022(kg/m)
	+	CF value of indoor unit(kg/EA)		

Note

For CF value (additional refrigerant) table of indoor units, please refer to PDB of indoor unit.

6. Refrigerant Piping System

6.3 Distribution Method

1. Line Distribution

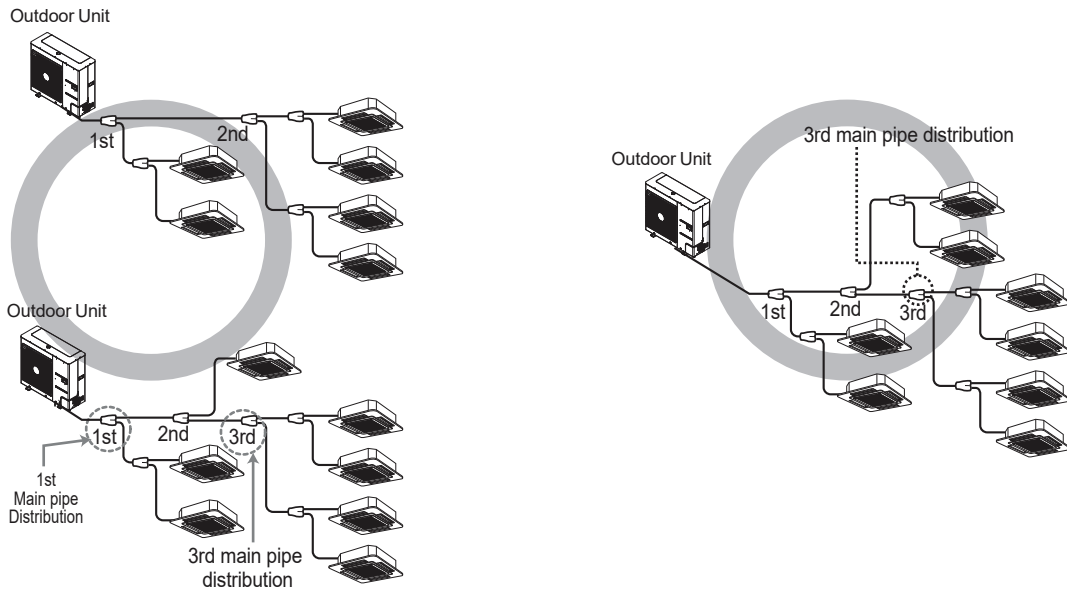

2. The others

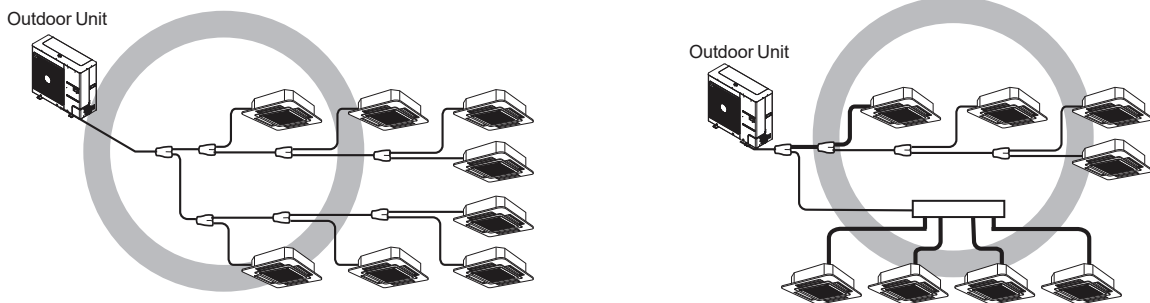

6. Refrigerant Piping System

6.4 Selection of Y Branch and Header

6.4.1 Y Branch

■ Cooling Only System

Models	Gas pipe [unit:mm]	Liquid pipe [unit:mm]
ARBLN01621		
ARBLN03321		
ARBLN07121		
ARBLN14521		
ARBLN23220		

6. Refrigerant Piping System

6.4.2 Header

■ Cooling Only system

Models	Gas pipe [Unit:mm]	Liquid pipe [Unit:mm]
4 branch ARBL054		
7 branch ARBL057		
4 branch ARBL104		
7 branch ARBL107		
10 branch ARBL1010		
10 branch ARBL2010		

7. Electrical Wiring

7.1 Electrical Wiring

7.1.1 Caution

1. Follow ordinance of your governmental organization for technical standard related to electrical equipment, wiring regulations and guidance of each electric power company.

⚠ WARNING

Be sure to have authorized electrical engineers do the electric work using special circuits in accordance with regulations and this installation manual. If power supply circuit has a lack of capacity or electric work deficiency, it may cause an electric shock or fire.

2. Install the Outdoor Unit communication line away from the power source wiring so that it is not affected by electric noise from the power source. (Do not run it through the same conduit.)
3. Be sure to provide designated grounding work to Outdoor Unit.

⚠ CAUTION

Be sure to correct the outdoor unit to earth. Do not connect earth line to any gas pipe, liquid pipe, lightning rod or telephone earth line. If earth is incomplete, it may cause an electric shock.

4. Give some allowance to wiring for electrical part box of Indoor and Outdoor Units, because the box is sometimes removed at the time of service work.
5. Never connect the main power source to terminal block of communication line. If connected, electrical parts will be burnt out.
6. Use 2-core shield cable for communication line. (○ mark in the figure below) If communication lines of different systems are wired with the same multiple-core cable, the resultant poor transmitting and receiving will cause erroneous operations. (⊗ mark in the figure below)
7. Only the communication line specified should be connected to the terminal block for Outdoor Unit communication.

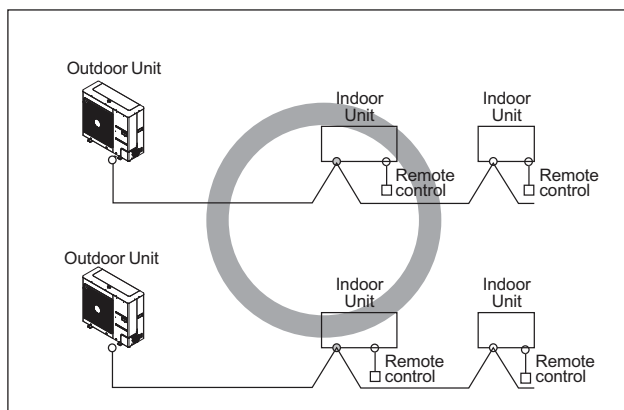

2-Core Shield Cable

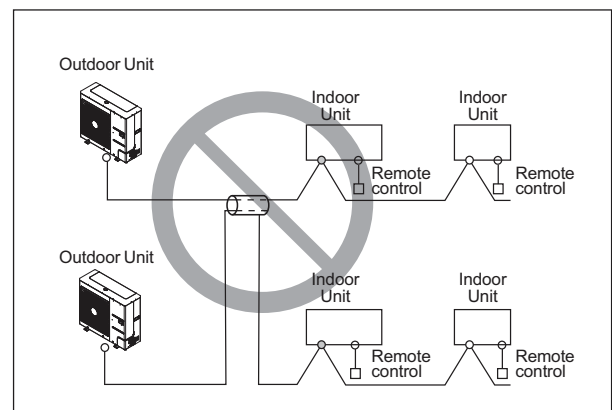

Multi-Core Cable

⚠ CAUTION

- This product have reversed phase protection detector that only works when the power is turned on. If there exists black out or the power goes on and off which the product is operating, attach a reversed

7. Electrical Wiring

phase protection circuit locally. running the product in reversed phase may break the compressor and other parts.

- Use the 2-core shield cables for communication lines. Never use them together with power cables.
- The conductive shielding layer of cable should be grounded to the metal part of both units.
- Never use multi-core cable
- As this unit is equipped with an inverter, to install a phase leading capacitor not only will deteriorate power factor improvement effect, but also may cause capacitor abnormal heating. Therefore, never install a phase leading capacitor.
- Make sure that the power unbalance ratio is not greater than 2%. If it is greater, the unit's lifespan will be reduced.
- Introducing with a missing N-phase or with a mistaken N-phase will break the equipment.

■ Precautions when laying power wiring

Use round pressure terminals for connections to the power terminal block.

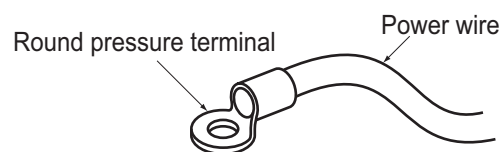

When none are available, follow the instructions below.

- Do not connect wiring of different thicknesses to the power terminal block. (Slack in the power wiring may cause abnormal heat.)
- When connecting wiring which is the same thickness, do as shown in the figure below.

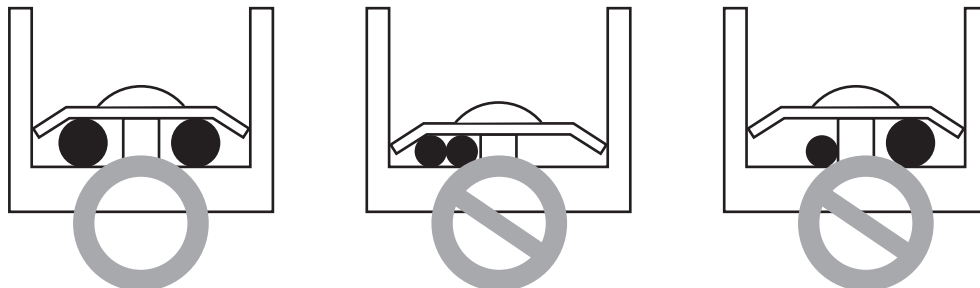

- For wiring, use the designated power wire and connect firmly, then secure to prevent outside pressure being exerted on the terminal block.
- Use an appropriate screwdriver for tightening the terminal screws. A screwdriver with a small head will strip the head and make proper tightening impossible.
- Over-tightening the terminal screws may break them.

⚠ CAUTION

When the 400 volt power supply is applied to "N" phase by mistake, replace inverter PCB and transformer in control box.

7. Electrical Wiring

■ Control box and connecting position of wiring

1. Remove the rear cover

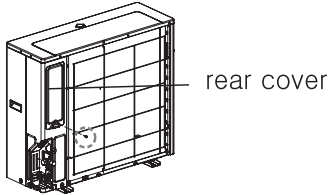

2. Tilt the cover more than 30 degrees.

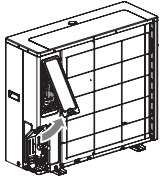

3. Remove the cover by pulling it in the direction of the arrow.

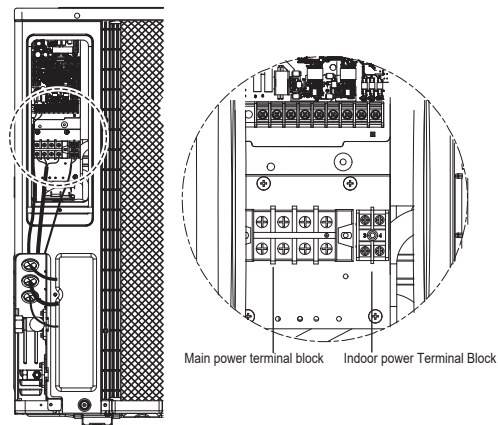
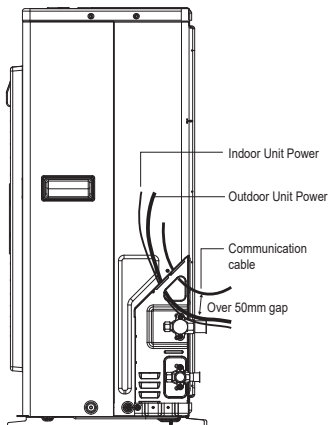
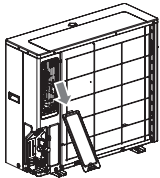

※Pictures may differ depending on the model.

7. Electrical Wiring

7.1.2 Communication and Power Lines

1. Communication cable

- Types: shielding cable
- Cross section: 1.0~1.5mm²
- Maximum allowable temperature: 60°C
- Maximum allowable cable length: under 300m

2. Remote control cable

- Types : 3-core cable

3. Central control cable

Product type	Cable type	Diameter
ACP	2-core wire (shielding wire)	1.0~1.5mm ²
AC Smart	2-core wire (shielding wire)	1.0~1.5mm ²
AC Ez	4-core wire (shielding wire)	1.0~1.5mm ²

4. Separation of communication and power lines

- If communication and power lines are run alongside each other then there is a strong likelihood of operational faults developing due to interference in the signal wiring caused by electrostatic and electromagnetic coupling.

The tables below indicates our recommendation as to appropriate spacing of communication and powerlines where these are to be run side by side

Current capacity of power line		Spacing
100V or more	10A	300mm
	50A	500mm
	100A	1,000mm
	Exceed 100A	1,500mm

Note

- The figures are based on assumed length of parallel cabling up to 100m. For length in excess of 100m the figures will have to be recalculated in direct proportion to the additional length of line involved.
- If the power supply waveform continues to exhibit some distortion the recommended spacing in the table should be increased.
 - If the cable are laid inside conduits then the following point must also be taken into account when grouping various cable together for introduction into the conduits
 - Power cable(including power supply to air conditioner) and communication cables must not be laid inside the same
 - In the same way, when grouping the power wires and communication cables should not be bunched together.

CAUTION

- If apparatus is not properly earthed then there is always a risk of electric shocks, the earthing of the apparatus must be carried out by a qualified person.
- Use a power wire pipe for the power wiring.

7. Electrical Wiring

7.2 DIP Switch Setting

7.2.1 Checking according to dip switch setting

You can check the setting values of the unit from the 7 segment LED.

The dip switch setting should be changed when the power is OFF.

7.2.2 Checking the setting of the unit

The number is sequentially appeared at the 7 segment in 5 seconds after applying the power. This number represents the setting condition.

- Initial display order

Order	No	Note
①	3~6	Model capacity
②	-	Waiting 10s
③	3~6	Model capacity
④	1	Cooling only
	2	Heat pump
⑤	38	380 V
	46	460 V
	22	220 V
⑥	1-255	Product type

- Example) ARUV060GSD6

①	②	③	④	⑤	⑥
6	-	6	1	22	2

Note

- Example of model names could be different with model names included within this PDB.
- In accordance with the number of combined outdoor unit or target region, it could not be applied to set the order ③,④.

7. Electrical Wiring

7.3 Automatic Addressing

- **The address of indoor units would be set by auto addressing**
 1. Wait for 3 minutes after supplying power.
 2. Press RED button of the outdoor units for 5 seconds. (SW1T)
 3. A "88" is indicated on 7-segment LED of the outdoor unit PCB.
 4. For completing addressing, 2~7 minutes are required depending on numbers of connected indoor units
 5. Numbers of connected indoor units whose addressing is completed are indicated for 30 seconds on 7-segment LED of the outdoor unit PCB
 6. After completing addressing, address of each indoor unit is indicated on the wired remote control display window. (CH01, CH02, CH03,, CH06 : Indicated as numbers of connected indoor units)

◆ Main PCB

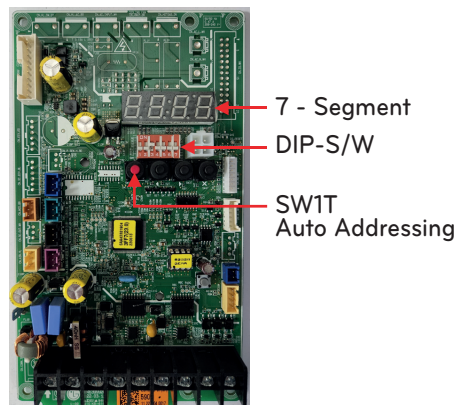

⚠ CAUTION

- In replacement of the indoor unit PCB, always perform Auto addressing setting again (At that time, please check about using Independent power module to any indoor unit.)
- If power supply is not applied to the indoor unit, operation error occur.
- Auto addressing is only possible on the Unit.
- Auto addressing has to be performed after 3 minutes to improve communication.

7. Electrical Wiring

■ The Procedure of Automatic Addressing

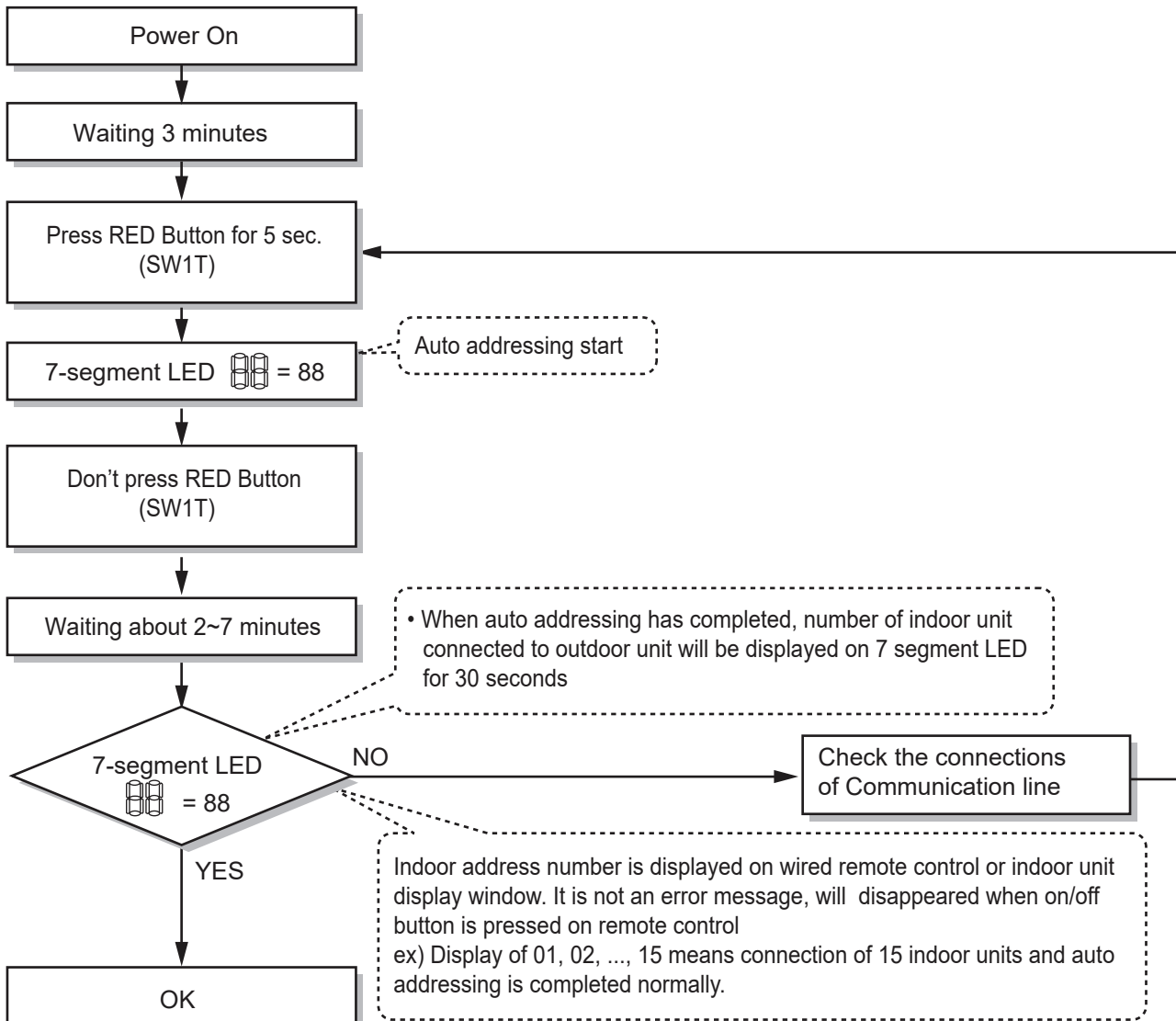

8. Setting the function

8.1 Night Low Noise Function

This function makes the ODU fan operate at low RPM to reduce the fan noise of ODU at night which has low load.

◆ Night low noise function setting method

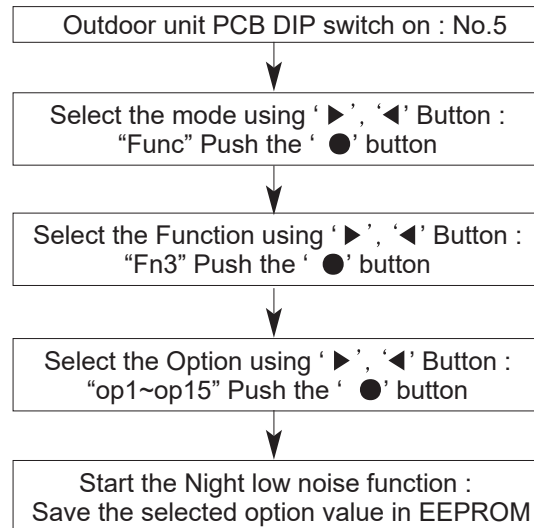

◆ Time Settings

Step	Judgement Time(Hr)	Operation Time(Hr)
oP1	8	9
oP2	6.5	10.5
oP3	5	12
oP4	8	9
oP5	6.5	10.5
oP6	5	12
oP7	8	9
oP8	6.5	10.5
oP9	5	12
oP10	continuous operation	
oP11	continuous operation	
oP12	continuous operation	
oP13	6.5	10.5
oP14	6.5	10.5
oP15	6.5	10.5

⚠ CAUTION

- Request installer to set the function during installation.
- If ODU RPM changes, capacity may go down.

MULTI V™ S
Outdoor Unit

Special Guide

- 1. Caution for Refrigerant Leak**
- 2. Installation Guide at the Seaside**

1. Caution For Refrigerant Leaks

The installer and system specialist shall secure safety against leakage according to local regulations or standards. The following standards may be applicable if local regulations are not available.

1.1 Introduction

The R410A refrigerant itself is harmless and nonflammable, but even if the refrigerant gas leaks into the room, the space for installing the air conditioner should be large enough that the refrigerant gas does not exceed the limit concentration.

1.1.1 Limiting concentration

Limiting concentration is the limit of Freon gas concentration where immediate measures can be taken without hurting human body when refrigerant leaks in the air. The limiting concentration shall be described in the unit of kg/m³ (Freon gas weight per unit air volume) for facilitating calculation.

Limiting concentration: 0.44kg/m³(R410A)

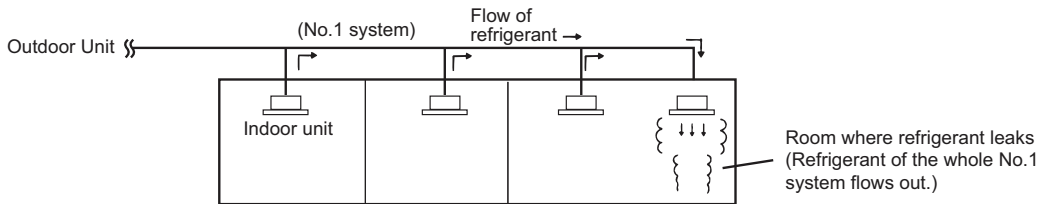

1.2 Checking procedure of limiting concentration

Check limiting concentration along following steps and take appropriate measure depending on the situation.

1.2.1 Calculate amount of all the replenished refrigerant (kg) per each refrigerant system.

◆ Calculate amount of all the replenished refrigerant (kg) per each refrigerant system.

Amount of replenished refrigerant per one outside unit system	+	Amount of additional replenished refrigerant	=	Total amount of replenished refrigerant in refrigerant facility (kg)
Amount of replenished refrigerant at factory shipment		Amount of additionally replenished refrigerant depending on piping length or piping diameter at customer		

Note

In case one refrigerant facility is divided into 2 or more refrigerant systems and each system is independent, amount of replenished refrigerant of each system shall be adopted.

1.2.2 Calculate minimum room volume

Calculate room volume by regarding a portion as one room or the smaller room.

1. Without partition

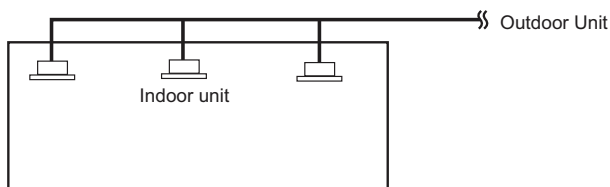

1. Caution For Refrigerant Leaks

2. With partition and with opening which serve as passage of air to adjoining room

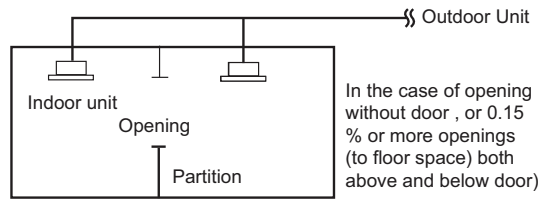

3. With partition and without opening which serve as passage of air to adjoining room

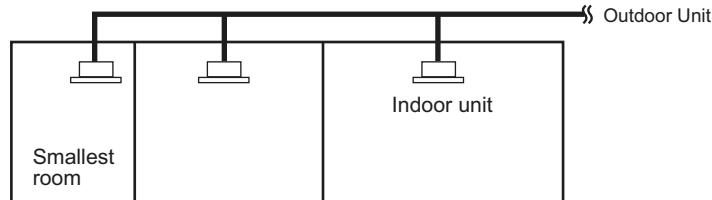

◆ Calculate refrigerant concentration

Total amount of replenished refrigerant in refrigerant facility (kg)

Volume of smallest room where indoor unit is installed (m³)

$$= \frac{\text{Refrigerant concentration}}{\text{(R410A)}} \quad (\text{kg/m}^3)$$

In case the result of calculation exceeds the limiting concentration, perform the same calculations by shifting to the second smallest, and the third smallest rooms until at last the result is below the limiting concentration.

◆ In case the concentration exceeds the limit

When the concentration exceeds the limit, change original plan or take one of the counter measure shown below:

- **Counter measure 1**
Provide opening for ventilation.
Provide 0.15% or more opening to floor space both above and below door, or provide opening without door.
- **Counter measure 2**
Provide gas leak alarm linked with mechanical ventilator.
Reducing the outdoor refrigerant qty.

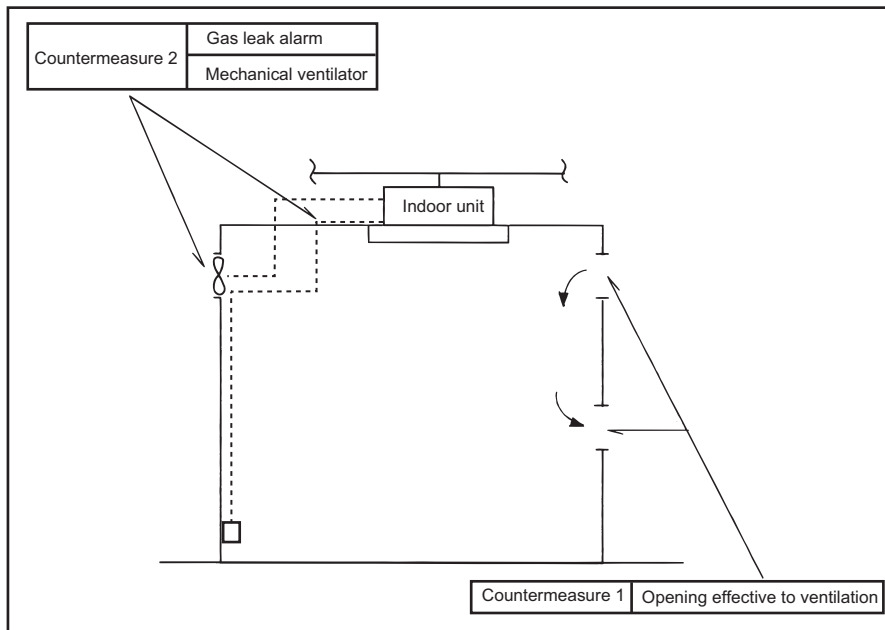

1. Caution For Refrigerant Leaks

CAUTION

Pay special attention to the place, such as a basement, etc. where refrigerant can stay, since refrigerant is heavier than air.

2. Installation Guide at the seaside

⚠ CAUTION

1. Air conditioners must not be installed in areas where corrosive gases, such as acid or alkaline gas, are present.
2. Do not install the product where it could be exposed to sea wind (salty wind) directly. As a result, the product is corroded. Corrosion, particularly on the condenser and evaporator fins, could cause product malfunction or inefficient performance.
3. If outdoor or indoor unit is installed close to the seaside, it should avoid direct exposure to the sea wind. Otherwise it needs additional corrosion resistance treatment on the heat exchanger.

2.1 Selecting the location(Outdoor Unit)

1. If the outdoor unit is to be installed close to the seaside, direct exposure to the sea wind should be avoided. Install the outdoor unit on the opposite side of the sea wind direction.

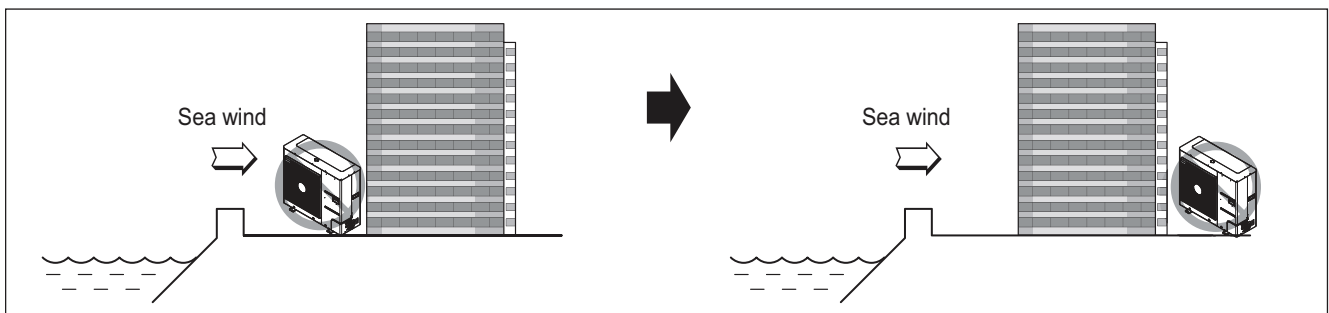

2. In case of outdoor installation on the seaside, a windbreak shield is mandatory to install not to allow exposure of the unit to the sea wind.

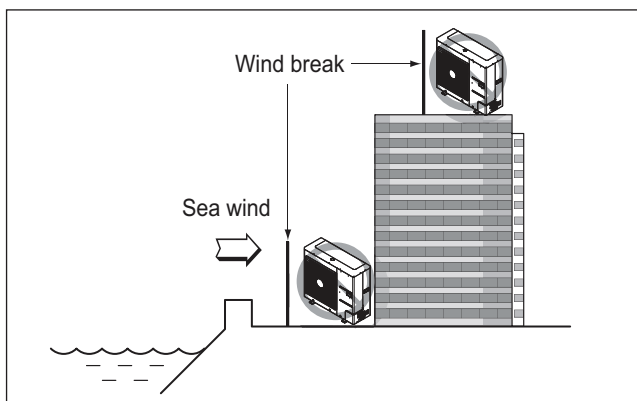

- It must be strong enough like concrete to prevent the sea wind from the sea.
- The height and width should be more than 150% of the outdoor unit.
- It must be kept more than 70 cm of space between outdoor unit and the windbreak for easy air flow.

3. Select a well-drained place.
4. Where the distance between the outdoor unit and the sea shore is more than 1km.
(Ensure the distance between the outdoor unit and the sea shore is more than 300m and less than 1km for the Corrosion Resistance models.)

⚠ CAUTION

- It needs the periodic (more than once/year) cleaning of the dust or salt particles stuck on the heat exchanger by using liquid.
- LG does not guarantee in case that periodic cleaning for heat exchanger is not doing or windbreak is not installed.

2. Installation Guide at the seaside

2.2 Installation and maintenance

Even though the corrosion resistance model has reinforced material or coating, it is still not completely safe from corrosion. And for this reason, you need to increase the effect of preventing corrosion through installation planning and maintenance/repair.

- Install the product where it will avoid salt water splash and beach sand as much as possible.
 - Install the machine in the direction the wind blows away from the building.
 - If you inevitably have to install the machine on by the shore, install a fence to block the wind to avoid direct contact from sea wind.
 - Be careful of the installation direction.
(The level of corrosion differs when the unit is parallel or vertical to the coast line.)
- Try to install the unit so that the particles from the sea side attached on the exterior panel can be sufficiently cleaned by the rain.
- Because the water collected within the floor of the outdoor unit significantly accelerates the corrosion process, make sure to install the unit so that water is well drained considering the inclination etc.
- For the outdoor unit installed on the sea shore, periodically wash the unit with clean water to remove any salt attached on the unit.
- Install the unit where it is well drained. Especially, secure good drainage at the floor part.
- Always repair dents caused from installation, maintenance etc.
- Periodically check the condition of the machine (Set water resistance treatment or replace parts, if necessary.)
- When you are not running the machine for a long period of time, such as during the off season, put a cover on the outdoor unit.
- Sufficiently maintain the machine well. (When installing the corrosion resistance coating such as water resistantgrease or wax, repeat the coating every 3 months)
Also, when install the machine in a special environment, you need to take separate consideration sufficiently.



Air Solution

LG Electronics Inc, 128, Yeoui-daero,
Yeongdeungpo-gu, Seoul, Korea
(07336)

<http://partner.lge.com>

<http://sedc.lge.com>

Copyright 2024 LG Electronics Inc.
All Rights Reserved.

The air conditioners manufactured by LG have received ISO9001 certificate for quality assurance and ISO14001 certificate for environmental management system.
The specifications, designs, and information in this brochure are subject to change without notice.