

# MULTI SPLIT

Advanced residential solution

**LG HVAC SOLUTION**



**LG Electronics**

<http://www.lg.com/ph>  
<http://partner.lge.com>

Copyright © 2021 LG Electronics. All rights reserved.

Distributed by



# INDEX

## 05 - 26 OUTDOOR UNIT

05 - 16  
KEY FEATURES

17 - 32  
SPECIFICATION



## 39 - 64 INDOOR UNIT

35 - 38  
KEY FEATURES

56  
SPECIFICATION



# OUTDOOR UNIT

KEY FEATURES

SPECIFICATION



# KEY FEATURES

## PERFECT SOLUTION FOR MULTIPLE ROOMS







**Energy Efficiency | Extreme Durability | Comfort and Convenience**

LG Multi split system provides powerful, efficient cooling and heating with two, three, four, or up to five indoor units operating off a single outdoor unit. LG's advanced inverter technology brings powerful performance while consuming less energy and it uses less space than installing individual single split systems. A variety of sleek and elegant indoor units to complement any décor are available in a full range of capacities for all room sizes. Installation is easy and it offers various convenient functions for easy maintenance.



# LINE-UP

## OUTDOOR UNIT

CATEGORY	kBTu/h kW	18	24	30	36	48
		5.3	7.1	8.8	10.6	14.1
Standard Efficiency	Connectable 1~2 IDUS (1Phase, 220V, 60Hz)					
	Connectable 1~3 IDUS (1Phase, 220V, 60Hz)					
	Connectable 1~4 IDUS (1Phase, 220V, 60Hz)					
High Efficiency	Connectable 1~5 IDUS (1Phase, 220V, 60Hz)					

## INDOOR UNIT

		kBTu/h Kw	9.0	12.0	18.0	24.0
			2.6	3.5	5.3	7.0
Wall Mount	Artcool		•	•	•	•
	Health+		•	•	•	•
	Standard+		•	•	•	•
Ceiling Mounted Cassette	1Way Cassette		•	•	•	•
	4Way Cassette			•	•	•
Ceiling Concealed Duct	Low Static Pressure		•	•	•	•

# FEATURE OVERVIEW

CATEGORY	FEATURE	MODEL				
		AZUQ18GFD0	A3UQ24GFD0	A3UQ30GFD0	A4UQ36GFD0	A5UQ48GFAI
Energy Efficiency	BLDC Compressor and Fan Motor	•	•	•	•	•
	Optimized Heat Exchanger Path	•	•	•	•	•
	Peak Current Control	•	•	•	•	•
Durability	Twin Rotary Compressor	•	•	•	•	•
	Smart Sensor Pressure Control		•	•	•	•
	Release Control	•	•	•	•	•
	Self Diagnosis	•	•	•	•	•
	Soft Start	•	•	•	•	•
	Phase Protection	•	•	•	•	•
	Test Function	•	•	•	•	•
	Re-Start Delay	•	•	•	•	•
Comfort and Convenience	Fast Cooling	•	•	•	•	•
	Night Silent Operation	•	•	•	•	•
	Wiring Error Check	•	•	•	•	•
	Monitoring PCB	•	•	•		•
	LGMV	•	•	•	•	•
	Forced Cooling Operation	•	•	•	•	•
	Central Controller			•	•	•

# ENERGY EFFICIENCY



## ENERGY EFFICIENCY

The advanced technologies of LG achieve the lowest energy consumption, especially SEER value.

World Class  
High Efficiency

SEER  
8.5

## Powerful BLDC (Brushless Direct Current Motor) Compressor

LG air conditioners are equipped with a BLDC Inverter Twin Rotary Compressor that uses a neodymium magnetic core. The compressor has high efficiency and superior reliability, because it is excellent in controlling the operating speed depending on the load. The compressor has improved efficiency compared to standard AC inverter products and optimized for changes of outdoor load. Especially it is optimized for seasonal efficiency.

### • Operation Range

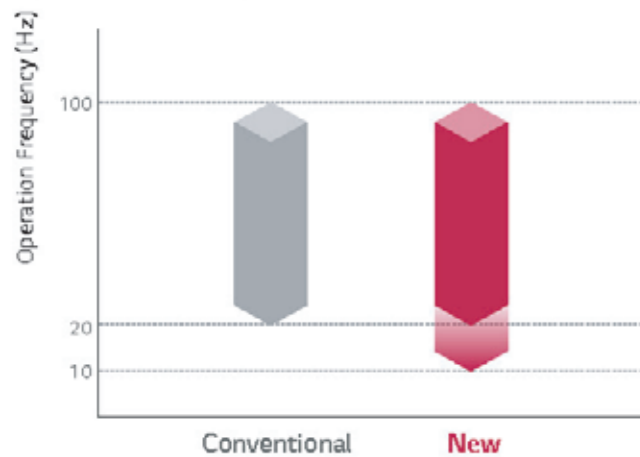

### • Motor Efficiency

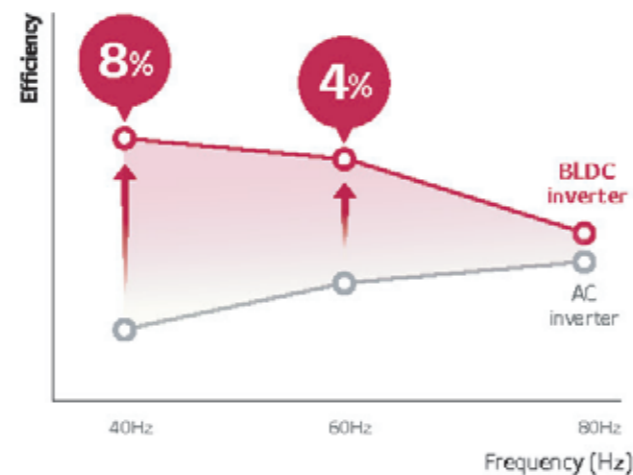

## Peak Current Control

The peak current control function keeps the air conditioner from running at the maximum level while maintaining current system setting, in order to reduce energy consumption. This function can help to cut energy costs during the peak periods of energy use when the energy fee is much higher.

### • How to set dip switch

**STEP 1** Max power consumption : 1.9 kW

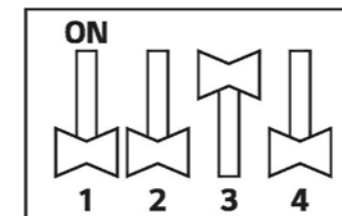

**STEP 2** Max power consumption : 1.7 kW

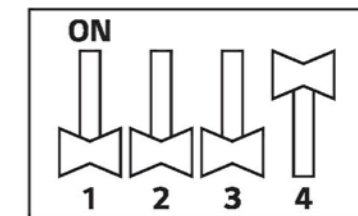

\* Full Load consumption : 2.5kW  
\* 7.0kW model  
\* LG Internal test result

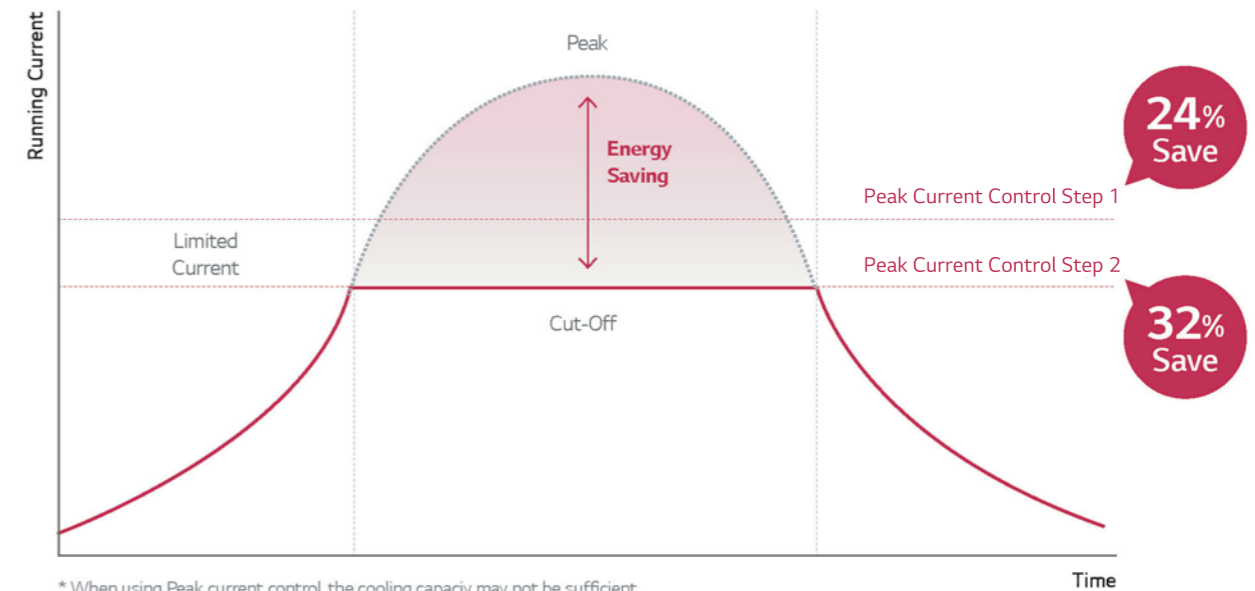

\* When using Peak current control, the cooling capacity may not be sufficient.  
\* 7.0kW model  
\* LG Internal test result

# EXTREME DURABILITY

## EXTREME DURABILITY

Product safety is emphasized by offering a 10-year warranty on the compressor to reassure customers about product durability.

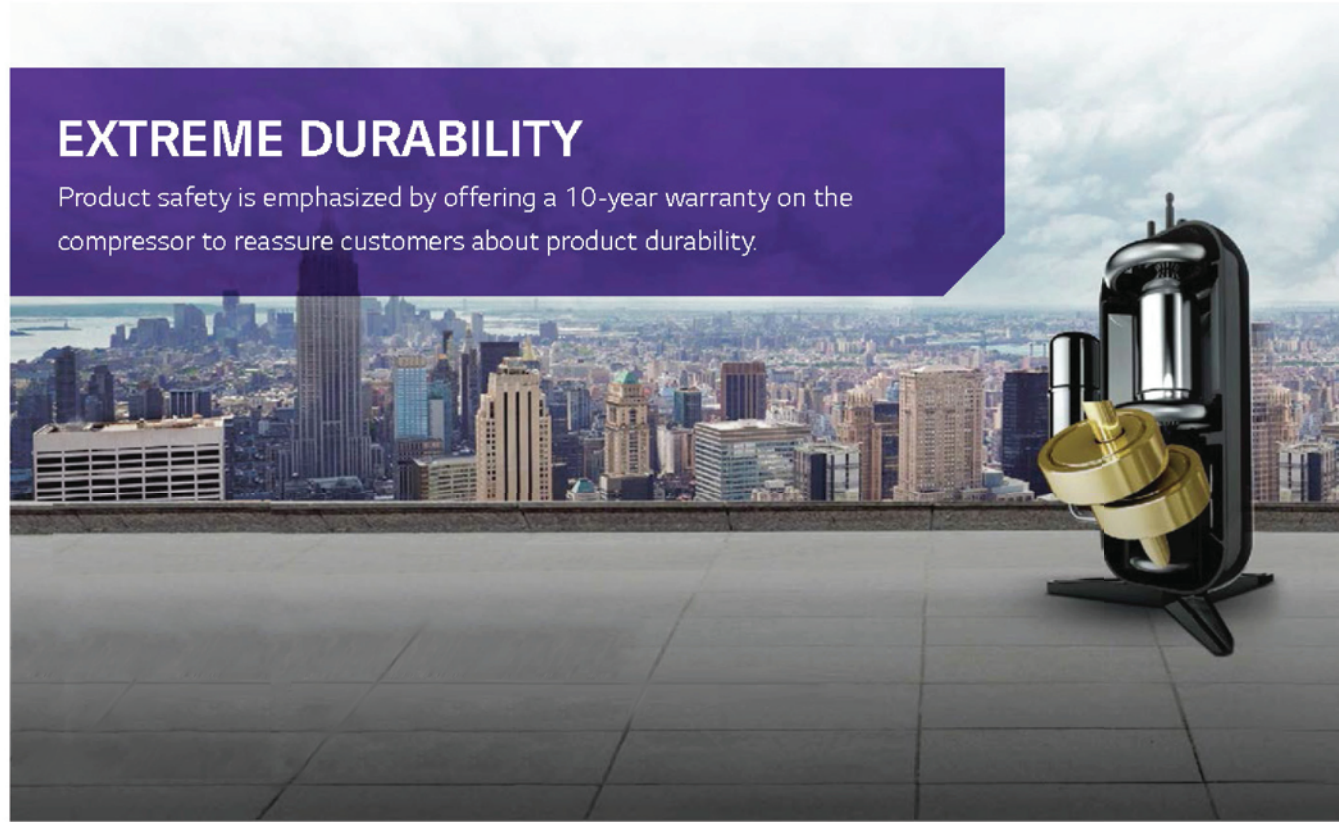

## Improved Inverter Twin Rotary Compressor

Parts of BLDC Inverter Twin Rotary Compressor have been improved to allow for a longer life span.

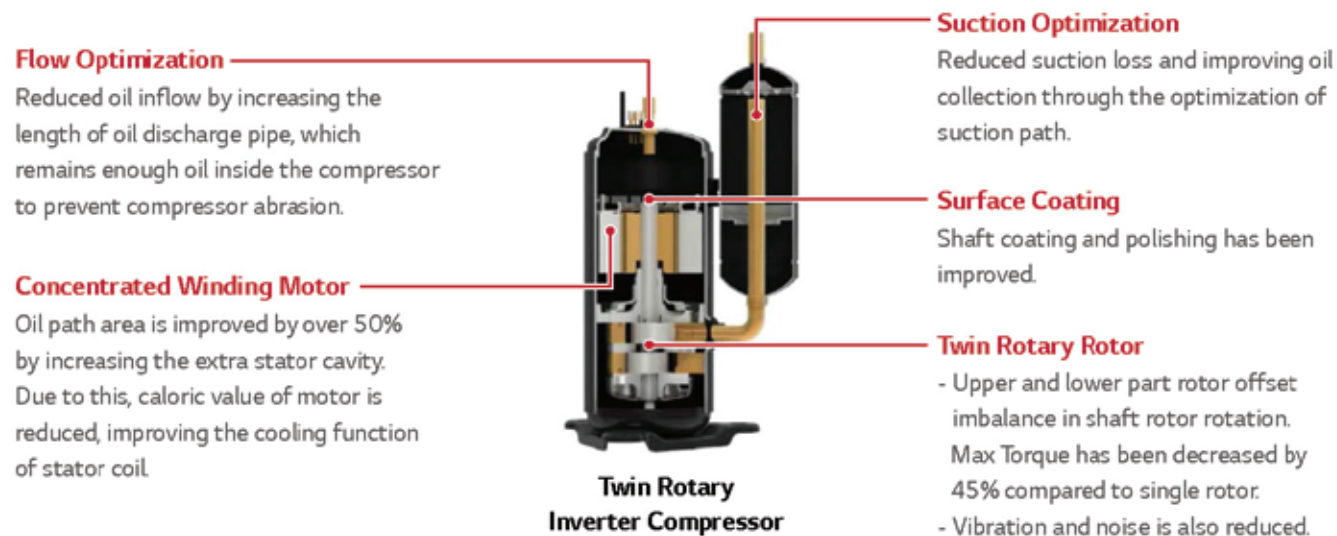

## Pressure Control Technology by Smart Sensor

Quicker and more reliable operation is possible from pressure control technology.

### • Field Failure Rate of Outdoor unit

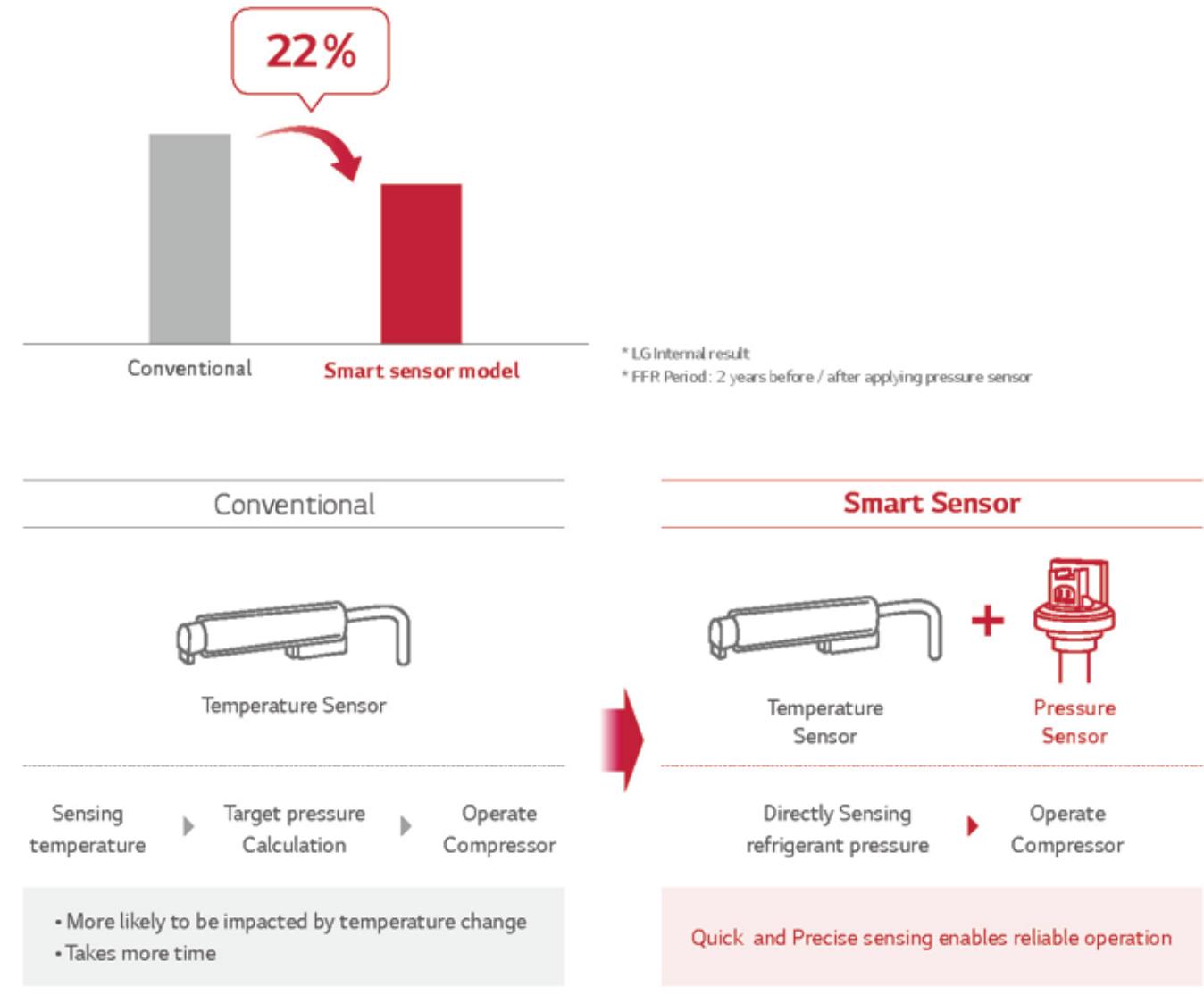

# COMFORT AND CONVENIENCE

## Monitoring PCB

If there is any problem, without disassembly of chassis, engineers can quickly check air conditioner's error code through 7-segment error indicator

**Conventional**

Many tools are needed for checking cycle data.

**Monitoring PCB**

Easy & Quick cycle data Check by Monitoring PCB

**STEP 1**  
Opening the control cover

3  
SCREW

**STEP 2**  
Simply Checking the data on PCB

7-segment error indicator

**STEP 3**  
Displayed Error code sample

### • Error Code List

Error Code	Contents	Case of Error	Outdoor Status
21	DC Link Peak (IPM Fault)	Over Rated Current	Off
22	CT 2 (Max CT)	Input Over Current	Off
23	DC Link Low Volt.	DC Link Volt is below 140V dc	Off
	DC Link High Volt.	DC Link Volt is above 420V dc	
25	Low Voltage / Over Voltage	Abnormal AC volt Input	Off
26	DC Compressor Position Error	Compressor Starting Fall Error	Off
27	PSC / PFC Fault Error	Over inverter PCB input Current	Off
29	COMP Over Current	Over inverter Compressor Current	Off

⋮

## LG MV (Monitoring Viewer)

LG MV helps engineers to inspect and monitor unit's operating status easily.

Mobile MV

PC based LGMV  
(for service)

LGMV module  
(for service)

Operation information

Cycle View

IDU & ODU Information

Cycle & Valves

Sensors & Electricity

Cycle Diagram

91/52/0.\*;+;0.42/-0+

## Forced Cooling Operation

The forced cooling operation allows refrigerant to be recharged or pumped down, regardless of the indoor temperature. More importantly this function can be used when indoor units are being moved or repaired.

**Recharging**

1 Close liquid valve  
2 Close gas valve

**Pump Down**



# COMFORT AND CONVENIENCE



## COMFORT AND CONVENIENCE

LG air conditioner always provides users with maximum levels of comfort and it is designed for an easy and efficient installation.

## Fast Cooling

Pressure control takes less time to reach the desired temperature up to 30% in cooling with high level of accuracy and stability.

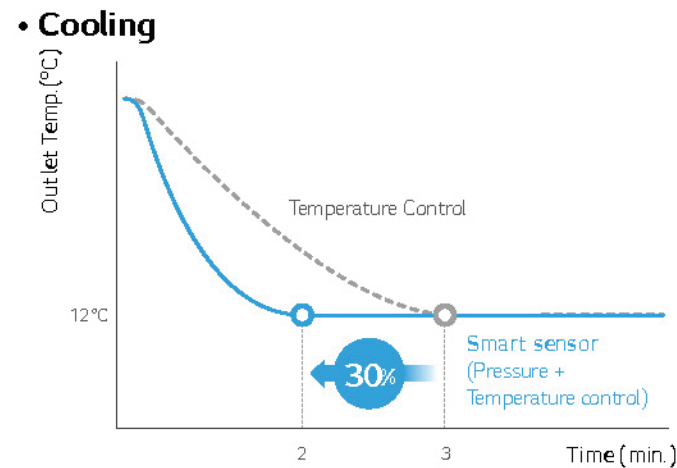

\* LG Internal test result

## Night Silent Operation

Night silent operation can reduce noise levels at night time by simply setting the dip switch on the PCB of the outdoor unit.

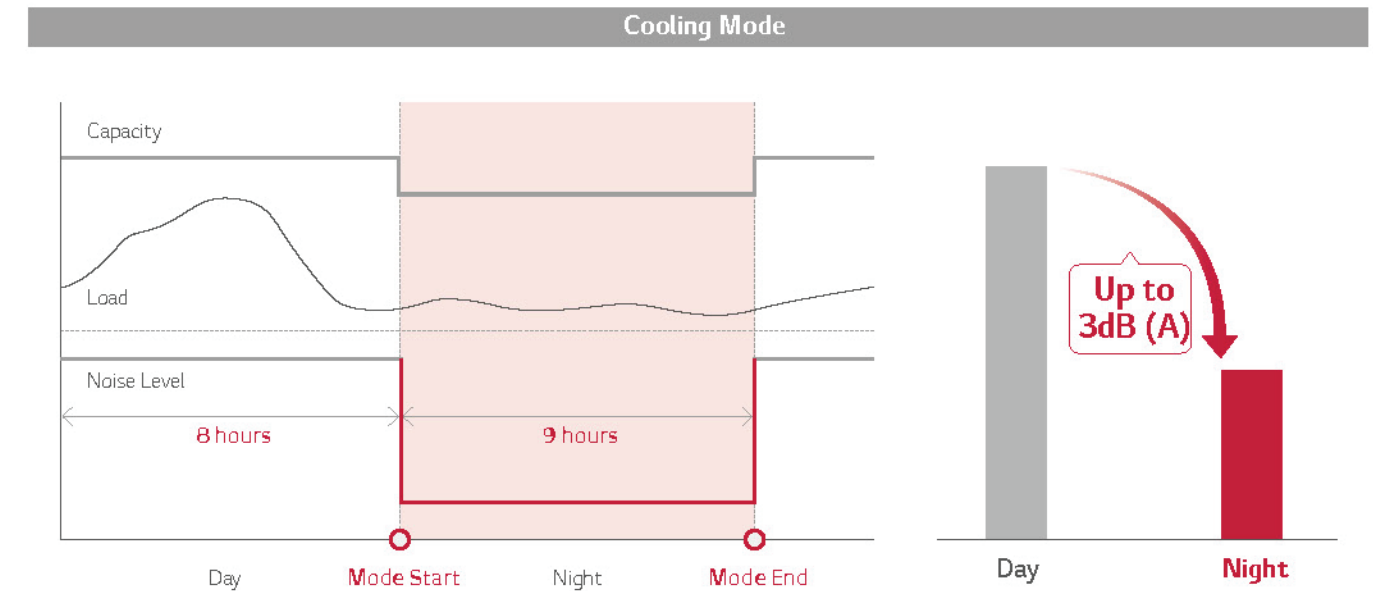

## Wiring Error Check

Installers can check whether the transmission cable has been connected correctly by using the wiring error check function. The wiring error check function can reduce the time taken to check for transmission cable errors.

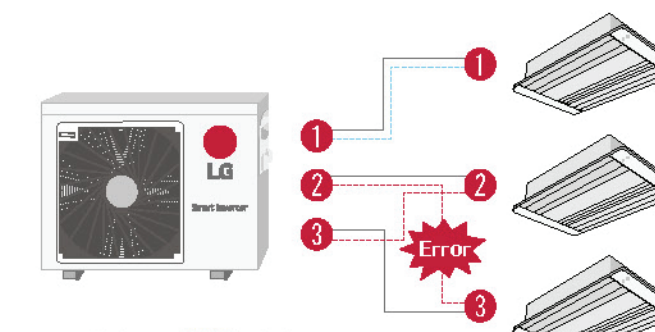

### • LED Result

- If the wiring is correct, the Green LED will light up.
- If the wiring is wrong, display as below
  - Red LED : Piping Number
  - Green LED : Wiring Number (Room)

Ex) If the Red LED blinks twice and the Green LED blinks 3 times, 2nd pipe is connected to 3rd room

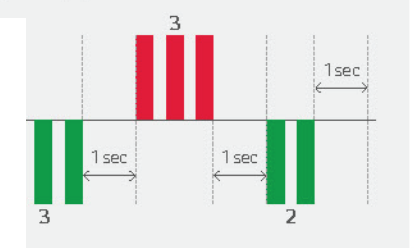

### • Pip Note :

- All data are based on the following conditions:
  - Cooling Temperature : Indoor 27°C(80.6°F) DB / 19°C(66.2°F) WB  
Outdoor 35°C(95°F) DB / 24°C(75.2°F) WB
  - Heating Temperature : Indoor 20°C(68°F) DB / 15°C(59°F) WB  
Outdoor 7°C(44.6°F) DB / 6°C(42.8°F) WB
  - Piping Length : Interconnected Pipe Length = 7.5m
  - Difference Limit of Elevation (Outdoor ~ Indoor Unit) is Zero.
- Wiring cable size must comply with the applicable local and national code.
- Due to our policy of innovation some specifications may be changed without notification.
- Sound Level Values are measured at Anechoic chamber.  
Therefore, these values can be increased owing to ambient conditions during opration.

# OUTDOOR UNITS



A2UQ18GFD0 / A3UQ24GFD0

Outdoor unit				A2UQ18GFD0	A3UQ24GFD0
Testing Combination				AMNC09GDBA2 x 2EA	AMNC09GDBA2 x 3EA
Capacity	Cooling	Min.~Rated~Max.	kW	1.45 ~ 5.0 ~ 6.1	1.45 ~ 7.0 ~ 7.7
		Min.~Rated~Max.	Btu/h	4,950 ~ 18,000 ~ 20,700	4,950 ~ 24,000 ~ 26,400
Power Input	Cooling	Min.~Rated~Max.	kW	0.47 ~ 1.63 ~ 2.00	0.47 ~ 2.13 ~ 2.80
Power Supply			V, ∅, Hz	230, 1, 50	230, 1, 50
				220, 1, 60	220, 1, 60
Running Current	Cooling	Min.~Rated~Max.	A	2.1 ~ 7.2 ~ 9.0	2.1 ~ 9.5 ~ 12.0
Wiring Connections	Power Supply Cable (included Earth)		No. x mm <sup>2</sup>	3C x 2.5	3C x 2.5
Combination	Sum of Indoor Units Capacity		kBtu/h	30	34
	Number of Indoor Units		EA	2	3
Casing Color				Warm Gray	Warm Gray
Dimensions	W x H x D		mm	770 x 545 x 288	770 x 545 x 288
	W x H x D		inch	34-1/4 x 25-25/32 x 12-19/32	34-1/4 x 25-25/32 x 12-19/32
Net Weight			kg (lbs)	36(79.4)	39(86)
Compressor	Type			Twin Rotary	Twin Rotary
	Model	Model x No.		GKT141MAC x 1	GKT176MAE x 1
	Motor type			BLDC	BLDC
	Motor Output	W x No.		1,500 (at 60Hz) x 1	1,500 (at 60Hz) x 1
Refrigerant	Type			R410A	R410A
	Precharged Amount	g (oz)		1,200 (42.3)	1,250 (44.1)
	Chargeless-Pipe Length	m (ft)		30(98.4)	50(164.0)
	Control			Electronic Expansion Valve	Electronic Expansion Valve
Refrigerant Oil	Type			FVC68D	FVC68D
	Charged volume	cc x No.		570x 1	670x 1
Heat Exchanger	(Row x Column x Fins per inch) x No.			(2 x 24 x 20) x 1	(2 x 24 x 20) x 1
Fan	Type			Propeller	Propeller
	Air Flow Rate	m <sup>3</sup> /min x No.		26 x 1	26 x 1
Fan Motor	Type			BLDC	BLDC
	Output	W x No.		43 x 1	43 x 1
Sound Pressure Level	Cooling	Rated	dB(A)	48	49
Piping Connections	Liquid	Outer Dia.	mm(inch) x No.	∅ 6.35 (1/4) x 2	∅ 6.35 (1/4) x 3
	Gas	Outer Dia.	mm(inch) x No.	∅ 9.52 (3/8) x 2	∅ 9.52 (3/8) x 3
Piping Length	Total Piping	Max.	m (ft)	30 (98.4)	50(164.0)
	Each Branch Piping	Max.	m (ft)	20 (65.6)	25 (82.0)
Maximum Height	Outdoor Unit ~ Indoor Unit		Max.	m (ft)	15 (49.2)
Difference	Indoor Unit ~ Indoor Unit		Max.	m (ft)	7.5 (24.6)
Operation Range (Outdoor Temperature)	Cooling	Min. ~ Max.	°C DB (°F DB)	-5(23.0) ~ 48 (118.4)	-5(23.0) ~ 48 (118.4)

**Note :**

- All data are based on the following conditions:  
 - Cooling Temperature : Indoor 27°C(80.6°F) DB / 19°C(66.2°F) WB  
 Outdoor 35°C(95°F) DB / 24°C(75.2°F) WB  
 - Heating Temperature : Indoor 20°C(68°F) DB / 15°C(59°F) WB  
 Outdoor 7°C(44.6°F) DB / 6°C(42.8°F) WB  
 - Piping Length : Interconnected Pipe Length = 7.5m  
 - Difference Limit of Elevation (Outdoor ~ Indoor Unit) is Zero.

- Wiring cable size must comply with the applicable local and national code.
- Due to our policy of innovation some specifications may be changed without notification.
- Sound Level Values are measured at Anechoic chamber.  
 Therefore, these values can be increased owing to ambient conditions during operation.



A3UQ30GFD0 / A4UQ36GFD0

Outdoor unit				A3UQ30GFD0	A4UQ36GFD0
Testing Combination				AMNC09GDBA2 x 3EA	AMNC09GDBA2 x 4EA
Capacity	Cooling	Min.~Rated~Max.	kW	2.8 ~ 8.8 ~ 9.3	2.8 ~ 10.5 ~ 11.7
		Min.~Rated~Max.	Btu/h	7,100 ~ 30,000 ~ 31,800	7,100 ~ 36,000 ~ 40,000
Power Input	Cooling	Min.~Rated~Max.	kW	0.68 ~ 2.7 ~ 2.90	0.68 ~ 3.1 ~ 3.75
Power Supply			V, ∅, Hz	230, 1, 50	230, 1, 50
				220, 1, 60	220, 1, 60
Running Current	Cooling	Min.~Rated~Max.	A	3.2 ~ 11.5 ~ 12.9	3.2 ~ 14.0 ~ 17.0
Wiring Connections	Power Supply Cable (included Earth)		No. x mm <sup>2</sup>	3C x 2.5	3C x 2.5
Combination	Sum of Indoor Units Capacity		kBtu/h	42	50
	Number of Indoor Units		EA	3	4
Casing Color				Warm Gray	Warm Gray
Dimensions	W x H x D		mm	870 x 655 x 320	950 x 834 x 330
	W x H x D		inch	34-1/4 x 25-25/32 x 12-19/32	37-13/32 x 32-27/32 x 13
Net Weight			kg (lbs)	45(99.2)	64 (141.1)
Compressor	Type			Twin Rotary	Twin Rotary
	Model	Model x No.		GKT176MAC x 1	GJT240MA x 1
	Motor type			BLDC	BLDC
	Motor Output	W x No.		1,500 (at 60Hz) x 1	2,137 (at 60Hz) x 1
Refrigerant	Type			R410A	R410A
	Precharged Amount	g (oz)		1,500 (52.9)	2,200 (112.9)
	Chargeless-Pipe Length	m (ft)		60(196.8)	70 (229.7)
	Control			Electronic Expansion Valve	Electronic Expansion Valve
Refrigerant Oil	Type			FVC68D	FVC68D
	Charged volume	cc x No.		670x 1	900 x 1
Heat Exchanger	(Row x Column x Fins per inch) x No.			(2 x 30 x 21) x 1	(2 x 40 x 21) x 1
Fan	Type			Propeller	Propeller
	Air Flow Rate	m <sup>3</sup> /min x No.		44 x 1	60 x 1
Fan Motor	Type			BLDC	BLDC
	Output	W x No.		85.4 x 1	124.2 x 1
Sound Pressure Level	Cooling	Rated	dB(A)	50	51
Piping Connections	Liquid	Outer Dia.	mm(inch) x No.	∅ 6.35 (1/4) x 4	∅ 6.35 (1/4) x 4
	Gas	Outer Dia.	mm(inch) x No.	∅ 9.52 (3/8) x 4	∅ 9.52 (3/8) x 4
Piping Length	Total Piping	Max.	m (ft)	60 (196.8)	70 (229.7)
	Each Branch Piping	Max.	m (ft)	25 (82.0)	25 (82.0)
Maximum Height	Outdoor Unit ~ Indoor Unit		Max.	m (ft)	15 (49.2)
Difference	Indoor Unit ~ Indoor Unit		Max.	m (ft)	7.5 (24.6)
Operation Range (Outdoor Temperature)	Cooling	Min. ~ Max.	°C DB (°F DB)	-5(23.0) ~ 48 (118.4)	-5(23.0) ~ 48 (118.4)

# OUTDOOR UNITS



A5UQ48GFA1

OUTDOOR UNIT				A5UQ48GFA1
Testing Combination		AMNQ09GSJ*0 x 4EAAMNQ12GSJ*0 x 1EA		
Capacity	Cooling	Min.~Rated~Max.	kW	2.05 ~ 14.10 ~ 15.50
		Min.~Rated~Max.	Btu/h	7,000 ~ 48,000~52,800
Power Input	Cooling	Min.~Rated~Max.	kW	0.60 ~ 4.40 ~ 5.64
Power Supply			V, Ø, Hz	230, 1, 50
Running Current	Cooling	Min.~Rated~Max.	A	220, 1, 60
WiringConnections	Power Supply Cable (included Earth)	No. x mm <sup>2</sup>		2.7 ~ 19.2 ~ 25.5
Combination	Sum of Indoor Units Capacity	kBtu/h		3C x 2.5
	Number of Indoor Units	EA		72
Casing Color				5
Dimensions	W x H x D	mm		Warm Gray
	W x H x D	inch		950 x 834 x 330
Net Weight		kg (lbs)		37-2/5 x 32-4/5 x 12-19/32
Compressor	Type			65(143.3)
	Model	Model x No.		Scroll
	Motor type			RJA036MAA x 1
	Motor Output	W x No.		BLDC
Refrigerant	Type			3,198 x 1
	Precharged Amount	g (oz)		R410A
	Chargeless-Pipe Length	m (ft)		2,200 (77.6)
	Additional Charging Volume	g/m (oz/ft)		37.5(123.0)
Refrigerant Oil	Control			20 (0.7)
	Type			Electronic Expansion Valve
	Charged volume	cc x No.		FVC68D
Heat Exchanger	#1 (Row x Column x Fins per inch) x No.			1,000 x 1
	#2 (Row x Column x Fins per inch) x No.			(3 x 40 x 21) x 1
Fan	Type			Propeller
	Air Flow Rate	m <sup>3</sup> /min x No.		70 x 1
Fan Motor	Type			BLDC
	Output	W x No.		124.2 x 1
Sound PressureLevel	Cooling (1m x 1.5m)	Rated	dB(A)	54
	Cooling (1m x C)	Rated	dB(A)	-
PipingConnections	Liquid	Outer Dia.	mm(inch) x No.	Ø 6.35 (1/4) x 5
	Gas	Outer Dia.	mm(inch) x No.	Ø 9.52 (3/8) x 5
Piping Length	Total Piping	Max.	m (ft)	85 (278.9)
	Each Branch Piping	Max.	m (ft)	25 (82.0)
Maximum Height	Outdoor Unit ~ Indoor Unit	Max.	m (ft)	15 (49.2)
Difference	Indoor Unit ~ Indoor Unit	Max.	m (ft)	7.5 (24.6)
Operation Range (Outdoor Temperature)	Cooling	Min. ~ Max.	°C DB (°F DB)	-5(23.0) ~ 48(118.4)

**Note :**

- All data are based on the following conditions:
  - Cooling Temperature : Indoor 27°C(80.6°F) DB / 19°C(66.2°F) WB  
Outdoor 35°C(95°F) DB / 24°C(75.2°F) WB
  - Heating Temperature : Indoor 20°C(68°F) DB / 15°C(59°F) WB  
Outdoor 7°C(44.6°F) DB / 6°C(42.8°F) WB
  - Piping Length : Interconnected Pipe Length = 7.5m
  - Difference Limit of Elevation (Outdoor ~ Indoor Unit) is Zero.

- Wiring cable size must comply with the applicable local and national code.
- Due to our policy of innovation some specifications may be changed without notification.
- Sound Level Values are measured at Anechoic chamber.  
Therefore, these values can be increased owing to ambient conditions during operation.

# OUTDOOR UNITS

UL2 Chassis	A2UQ18GFD0	<p>3D View</p>	
		<p>Side View (removed valve cover)</p>	
		<p>Front View</p>	
		<p>Rear View</p>	
		<p>Bottom View</p>	
		<p>Top View</p>	
		<p>4. Inlets for Analog. Refrigerant</p>	
		<p>Ø 10. Inlets for Drain Connection</p>	

No.	Part Name	Description
9	Intake air temperature sensor cover	
8	Handle	
7	Refrigerant pipe routing hole	
6	Power and Communication cable routing hole	
5	Liquid Pipe connection	
4	Gas Pipe connection	
3	Power and communication cable connection	
2	Control cover & SVC valve cover	
1	Air Outlet	



**Note**

- Unit should be installed in compliance with the installation manual in the product box.
- Unit should be grounded in accordance with the local regulations or applicable national codes.
- All electrical components and materials to be supplied from the site must comply with the local regulations or international codes.
- Electric characteristics chapter should be considered for electrical work and design. Especially, the power cable and circuit breaker should be selected in accordance with that.

**Symbols**

- Datum line
- Refrigerant/Drain Piping Direction

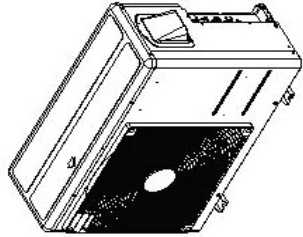
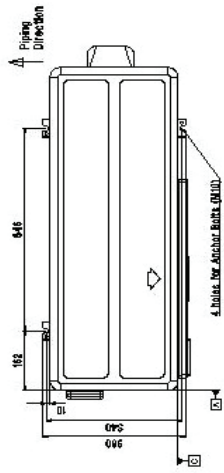
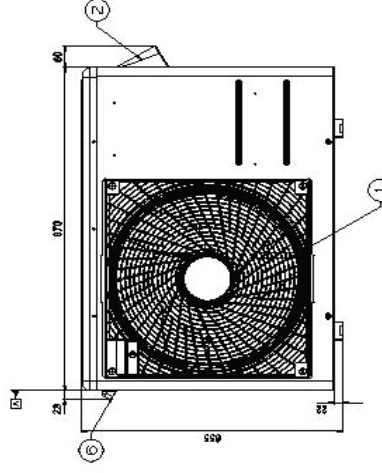
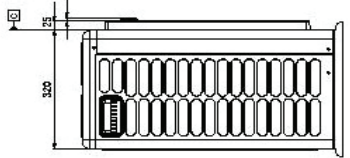
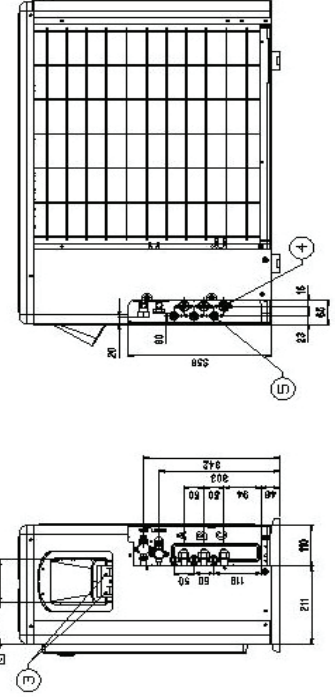
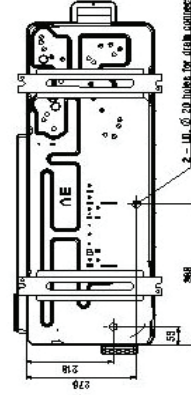
# OUTDOOR UNITS

UE Chassis A3UQ30GFD0	 <p>3D View</p>																																										
 <p>4 - 1/2" IN. Ø. 20 TUBES FOR LIQUID CONNECTION</p>	 <p>2 - 1/2" IN. Ø. 20 TUBES FOR LIQUID CONNECTION</p>																																										
																																											
																																											
<p><b>Symbols</b></p> <p>— Piping Direction</p> <p>— Datum line</p>	<p><b>Note</b></p> <ol style="list-style-type: none"> <li>Unit should be installed in compliance with the installation manual in the product box.</li> <li>Unit should be grounded in accordance with the local regulations or applicable national codes.</li> <li>All electrical components and materials to be supplied from the site must comply with the local regulations or international codes.</li> <li>Electrical characteristics chapter should be considered for electrical work and design. Especially, the power cable and circuit breaker should be selected in accordance with that.</li> </ol>																																										
<table border="1" style="width: 100%; border-collapse: collapse;"> <thead> <tr> <th>No.</th> <th>Part Name</th> <th>Description</th> </tr> </thead> <tbody> <tr> <td>6</td> <td>Handle</td> <td>-</td> </tr> <tr> <td>5</td> <td>Liquid Pipe Connection</td> <td>Flare joint</td> </tr> <tr> <td>4</td> <td>Gas Pipe Connection</td> <td>Flare joint</td> </tr> <tr> <td>3</td> <td>Power and communication Cable Hole</td> <td>-</td> </tr> <tr> <td>2</td> <td>Control Cover</td> <td>-</td> </tr> <tr> <td>1</td> <td>Air Outlet</td> <td>-</td> </tr> </tbody> </table>	No.	Part Name	Description	6	Handle	-	5	Liquid Pipe Connection	Flare joint	4	Gas Pipe Connection	Flare joint	3	Power and communication Cable Hole	-	2	Control Cover	-	1	Air Outlet	-	<table border="1" style="width: 100%; border-collapse: collapse;"> <thead> <tr> <th>No.</th> <th>Part Name</th> <th>Description</th> </tr> </thead> <tbody> <tr> <td>6</td> <td>Handle</td> <td>-</td> </tr> <tr> <td>5</td> <td>Liquid Pipe Connection</td> <td>Flare joint</td> </tr> <tr> <td>4</td> <td>Gas Pipe Connection</td> <td>Flare joint</td> </tr> <tr> <td>3</td> <td>Power and communication Cable Hole</td> <td>-</td> </tr> <tr> <td>2</td> <td>Control Cover</td> <td>-</td> </tr> <tr> <td>1</td> <td>Air Outlet</td> <td>-</td> </tr> </tbody> </table>	No.	Part Name	Description	6	Handle	-	5	Liquid Pipe Connection	Flare joint	4	Gas Pipe Connection	Flare joint	3	Power and communication Cable Hole	-	2	Control Cover	-	1	Air Outlet	-
No.	Part Name	Description																																									
6	Handle	-																																									
5	Liquid Pipe Connection	Flare joint																																									
4	Gas Pipe Connection	Flare joint																																									
3	Power and communication Cable Hole	-																																									
2	Control Cover	-																																									
1	Air Outlet	-																																									
No.	Part Name	Description																																									
6	Handle	-																																									
5	Liquid Pipe Connection	Flare joint																																									
4	Gas Pipe Connection	Flare joint																																									
3	Power and communication Cable Hole	-																																									
2	Control Cover	-																																									
1	Air Outlet	-																																									

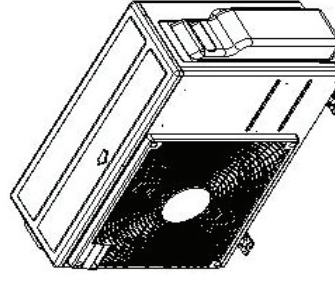
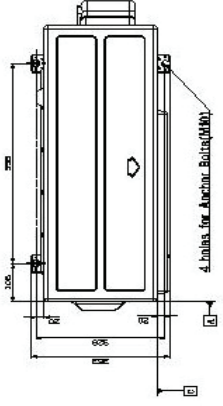
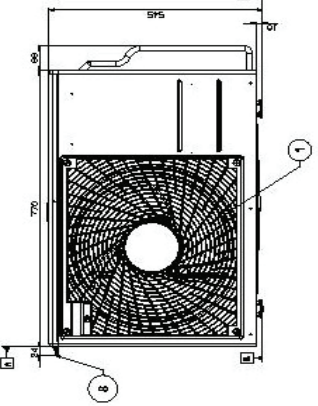
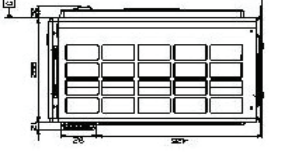
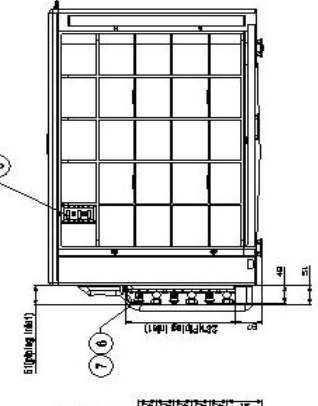
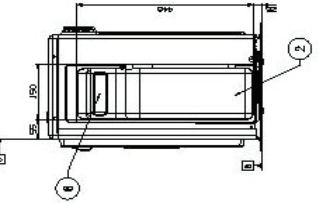
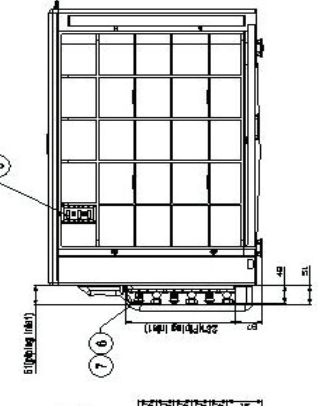
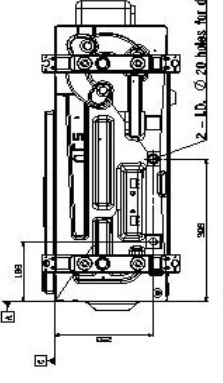
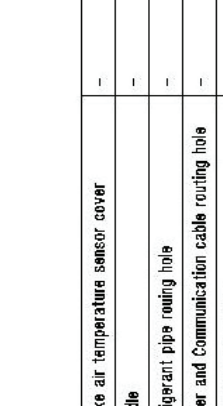
UL2 Chassis A3UQ24GFD0	 <p>3D View</p>																																																												
 <p>4 - 1/2" IN. Ø. 20 TUBES FOR LIQUID CONNECTION</p>																																																													
																																																													
	 <p>Side View (removed valve cover)</p>																																																												
																																																													
<p><b>Symbols</b></p> <p>— Datum line</p> <p>— Refrigerant/Drain Piping Direction</p>	<p><b>Note</b></p> <ol style="list-style-type: none"> <li>Unit should be installed in compliance with the installation manual in the product box.</li> <li>Unit should be grounded in accordance with the local regulations or applicable national codes.</li> <li>All electrical components and materials to be supplied from the site must comply with the local regulations or international codes.</li> <li>Electric characteristics chapter should be considered for electrical work and design. Especially, the power cable and circuit breaker should be selected in accordance with that.</li> </ol>																																																												
<table border="1" style="width: 100%; border-collapse: collapse;"> <thead> <tr> <th>No.</th> <th>Part Name</th> <th>Description</th> </tr> </thead> <tbody> <tr> <td>9</td> <td>Intake air temperature sensor cover</td> <td>-</td> </tr> <tr> <td>8</td> <td>Handle</td> <td>-</td> </tr> <tr> <td>7</td> <td>Refrigerant pipe routing hole</td> <td>-</td> </tr> <tr> <td>6</td> <td>Power and communication cable routing hole</td> <td>-</td> </tr> <tr> <td>5</td> <td>Liquid Pipe connection</td> <td>-</td> </tr> <tr> <td>4</td> <td>Gas Pipe connection</td> <td>-</td> </tr> <tr> <td>3</td> <td>Power and communication cable connection</td> <td>-</td> </tr> <tr> <td>2</td> <td>Control cover &amp; SVC valve cover</td> <td>-</td> </tr> <tr> <td>1</td> <td>Air Outlet</td> <td>-</td> </tr> </tbody> </table>	No.	Part Name	Description	9	Intake air temperature sensor cover	-	8	Handle	-	7	Refrigerant pipe routing hole	-	6	Power and communication cable routing hole	-	5	Liquid Pipe connection	-	4	Gas Pipe connection	-	3	Power and communication cable connection	-	2	Control cover & SVC valve cover	-	1	Air Outlet	-	<table border="1" style="width: 100%; border-collapse: collapse;"> <thead> <tr> <th>No.</th> <th>Part Name</th> <th>Description</th> </tr> </thead> <tbody> <tr> <td>9</td> <td>Intake air temperature sensor cover</td> <td>-</td> </tr> <tr> <td>8</td> <td>Handle</td> <td>-</td> </tr> <tr> <td>7</td> <td>Refrigerant pipe routing hole</td> <td>-</td> </tr> <tr> <td>6</td> <td>Power and communication cable routing hole</td> <td>-</td> </tr> <tr> <td>5</td> <td>Liquid Pipe connection</td> <td>-</td> </tr> <tr> <td>4</td> <td>Gas Pipe connection</td> <td>-</td> </tr> <tr> <td>3</td> <td>Power and communication cable connection</td> <td>-</td> </tr> <tr> <td>2</td> <td>Control cover &amp; SVC valve cover</td> <td>-</td> </tr> <tr> <td>1</td> <td>Air Outlet</td> <td>-</td> </tr> </tbody> </table>	No.	Part Name	Description	9	Intake air temperature sensor cover	-	8	Handle	-	7	Refrigerant pipe routing hole	-	6	Power and communication cable routing hole	-	5	Liquid Pipe connection	-	4	Gas Pipe connection	-	3	Power and communication cable connection	-	2	Control cover & SVC valve cover	-	1	Air Outlet	-
No.	Part Name	Description																																																											
9	Intake air temperature sensor cover	-																																																											
8	Handle	-																																																											
7	Refrigerant pipe routing hole	-																																																											
6	Power and communication cable routing hole	-																																																											
5	Liquid Pipe connection	-																																																											
4	Gas Pipe connection	-																																																											
3	Power and communication cable connection	-																																																											
2	Control cover & SVC valve cover	-																																																											
1	Air Outlet	-																																																											
No.	Part Name	Description																																																											
9	Intake air temperature sensor cover	-																																																											
8	Handle	-																																																											
7	Refrigerant pipe routing hole	-																																																											
6	Power and communication cable routing hole	-																																																											
5	Liquid Pipe connection	-																																																											
4	Gas Pipe connection	-																																																											
3	Power and communication cable connection	-																																																											
2	Control cover & SVC valve cover	-																																																											
1	Air Outlet	-																																																											

# OUTDOOR UNITS

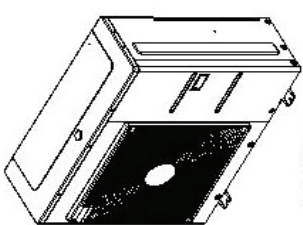
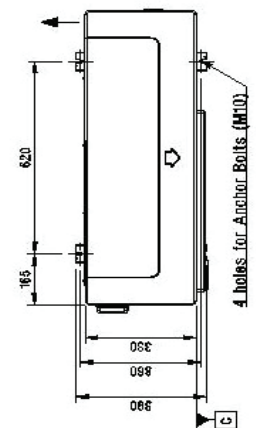
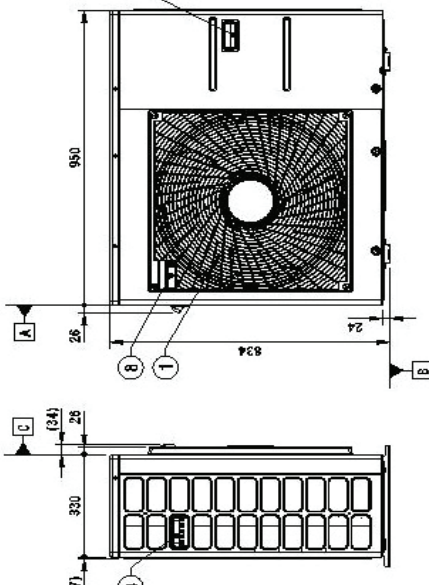
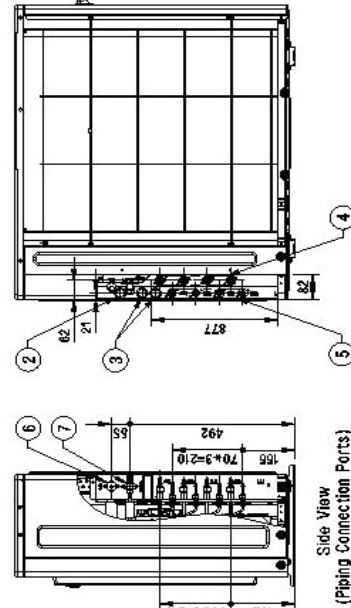
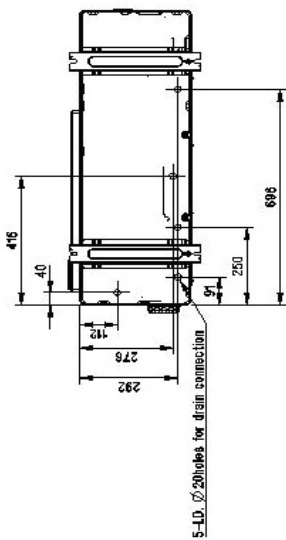
U4 Chassis A4UQ36GFD0	 <p>3D View</p>  <p>4 holes for Anchor Bolts (M10)</p>  <p>Side View (Piping Connection Ports)</p>  <p>Side View</p>  <p>5-<math>\phi</math> 20 holes for drain connection</p>
--------------------------	--

[Unit: mm]

No.	Part Name	Description
8	Handle	-
7	SVC Valve (Liquid)	-
6	SVC Valve (Gas)	-
5	Liquid Pipe Connection	Flare joint
4	Gas Pipe Connection	Flare joint
3	Power and communication cable Hole	ODU-IDU connection
2	Power Supply cable Hole	ODU power supply
1	Air Outlet	-

[Unit: mm]

**Note**

- Unit should be installed in compliance with the installation manual in the product box.
- Unit should be grounded in accordance with the local regulations or applicable national codes.
- All electrical components and materials to be supplied from the site must comply with the local regulations or international codes.
- Electric characteristics chapter should be considered for electrical work and design. Especially the power cable and circuit breaker should be selected in accordance with that.

**Symbols**

- Piping Direction
- Datum line

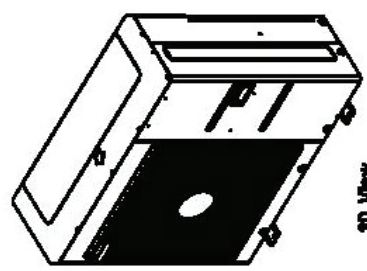
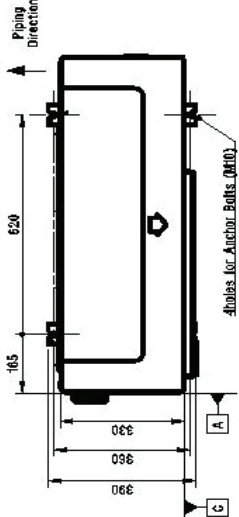
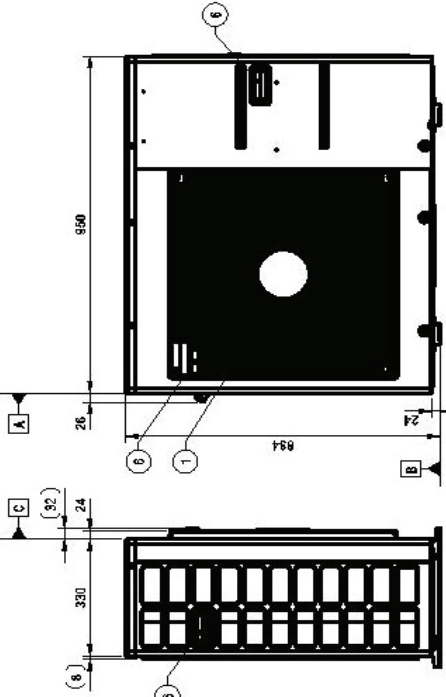
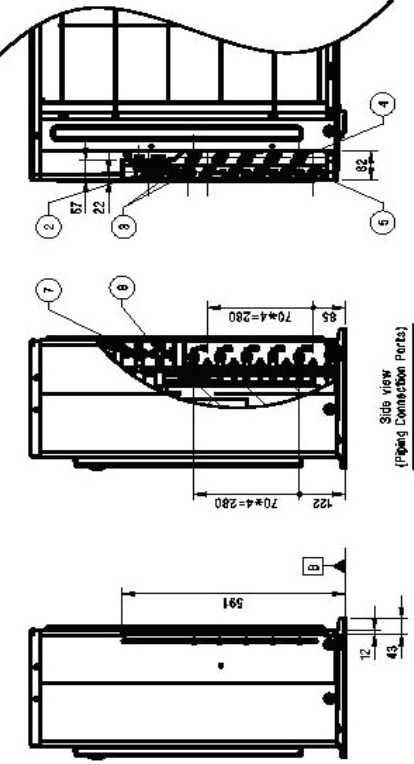
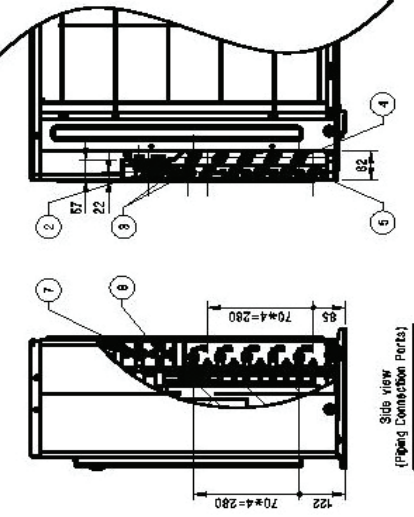
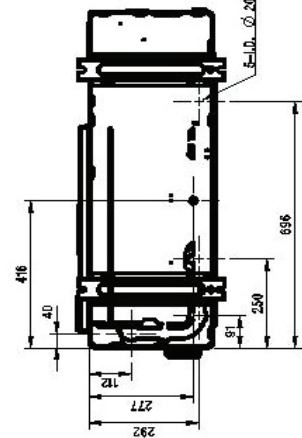
U4 Chassis A5UQ48GFA1	 <p>3D View</p>  <p>4 holes for Anchor Bolts (M10)</p>  <p>Side View</p>  <p>Side view (Piping Connection Ports)</p>   <p>5-<math>\phi</math> 20 holes for drain connection</p>
--------------------------	---

[Unit: mm]

No.	Part Name	Description
8	SVC Valve (Liquid)	Flare joint
7	SVC Valve (Gas)	Flare joint
6	Handle	-
5	Liquid pipe Connection	Flare joint
4	Gas pipe Connection	Flare joint
3	Power and Communication Cable holes	ODU-IDU connection
2	Power Supply cable Hole	ODU power supply
1	Air Outlet	-

[Unit: mm]

**Note**

- Unit should be installed in compliance with the installation manual in the product box.
- Unit should be grounded in accordance with the local regulations or applicable national codes.
- All electrical components and materials to be supplied from the site must comply with the local regulations or international codes.
- Electric characteristics chapter should be considered for electrical work and design. Especially the power cable and circuit breaker should be selected in accordance with that.

**Symbols**

- Piping Direction
- Datum line

# INSTALLATION OF OUTDOOR UNIT

## Selection of the best location

This Multi F & Multi F DX unit is suitable for installation in a residential and commercial environmental situation. If installed near a household appliance it can cause electromagnetic interference. The units should be installed in a location that meets the following requirements:

- ① A robust and strong base which can support the weight of the unit and will not degrade easily
- ② If an awning is built over the unit to prevent direct sunlight or rain exposure, make sure that the discharge air of the condenser is not restricted.
- ③ It is recommended that the outdoor unit should be fenced to avoid animals or plants being exposed in the direct path of the discharged air .
- ④ Ensure proper spaces between the unit and its surrounding as given in the figure.
- ⑤ Ensure that the water shall not cause any damage by overflowing in case of water condensation
- ⑥ The noise, vibration and hot discharged air of the outdoor unit should not annoy the surrounding environment.
- ⑦ Ensure that there is no damage to the pipes in long run as it may cause the refrigerant leakage.
- ⑧ In case the outdoor may have heavy snow : a. Make foundation at a suitable height.  
b. Fit a suitable hood or a awning over the unit.
- ⑨ Rooftop Installations : If the outdoor unit is installed on a roof structure, be sure to level the unit. Ensure the roof structure and anchoring method are adequate for the unit location. Consult local codes regarding rooftop mounting.

## Clearance around outdoor unit

- Ensure that the space around the back is more than 300 mm on the opposite to the PCB side and secure 600 mm space near the compressor and PCB side of the air conditioner for service.

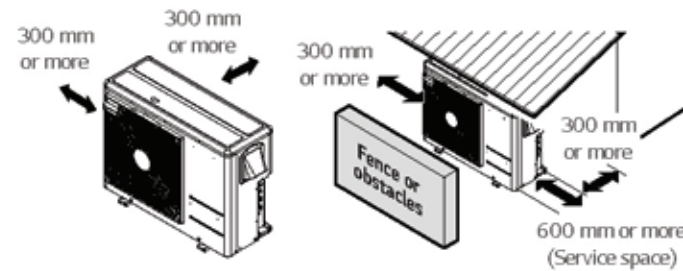

\* Outdoor unit is representative. Actual appearance of outdoor unit may be different but clearances will stay the same.

## Installation guide at the seaside

### CAUTION

1. Air conditioners should not be installed in areas where corrosive gases, such as acid or alkaline gas, are produced.
2. Do not install the product where it could be exposed to sea wind (salty wind) directly. It can result corrosion on the product. Corrosion, particularly on the condenser and evaporator fins, could cause product malfunction or inefficient performance.
3. If outdoor unit is installed close to the seaside, it should avoid direct exposure to the sea wind. Otherwise it needs additional anticorrosion treatment on the heat exchanger

### • Selecting the location(Outdoor Unit)

- 1) If the outdoor unit is to be installed close to the seaside, direct exposure to the sea wind should be avoided. Install the outdoor unit on the opposite side of the sea wind direction.

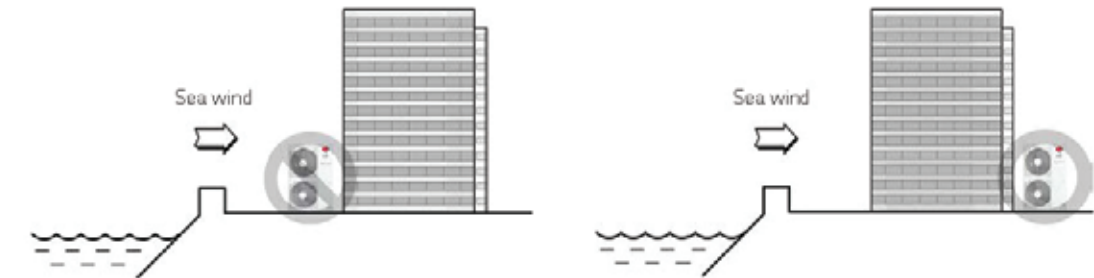

- 2) In case, to install the outdoor unit on the seaside, set up a windbreak not to be exposed to the sea wind.

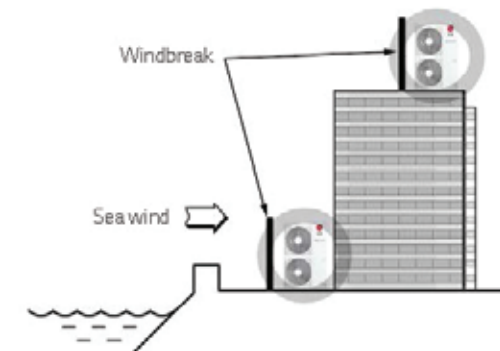

- It should be strong enough like concrete to prevent the sea wind from the sea.
- The height and width should be more than 150% of the outdoor unit.
- It should be keep more than 70 cm of space between outdoor unit and the windbreak for easy air flow.

- 3) Select a well-drained place

Periodic ( more than once/year ) cleaning of the dust or salt particles stuck on the heat exchanger by using water

# OUTDOOR UNITS

## Models : A2UQ18GFD0

### Cooling

Operation	Combination (kBtu/h)			Each Capacity (Btu/h)			Total Capacity (Btu/h)			Total Input (W)			Total Current (A)		
	Unit-A	Unit-B	Total	Unit-A	Unit-B	Min	Rated	Max	Min	Rated	Max	Min	Rated	Max	
1 UNIT	9	-	9	9,000	-	4,950	9,000	10,800	470	780	1,020	2.1	3.5	4.6	
	12	-	12	12,000	-	6,600	12,000	14,400	530	900	1,310	2.4	4.1	5.9	
	18	-	18	18,000	-	9,900	18,000	20,700	918	1,630	2,000	4.2	7.2	9.0	
	18	9	18	9,000	9,000	9,900	18,000	20,700	918	1,630	2,000	4.2	7.2	9.0	
2 UNIT	9	12	21	7,714	10,286	9,900	18,000	20,700	918	1,630	2,000	4.2	7.2	9.0	
	9	18	27	6,000	12,000	9,900	18,000	20,700	918	1,630	2,000	4.2	7.2	9.0	
	12	12	24	9,000	9,000	9,900	18,000	20,700	918	1,630	2,000	4.2	7.2	9.0	
	12	18	30	7,200	10,800	9,900	18,000	20,700	918	1,630	2,000	4.2	7.2	9.0	
	18	18	36	10,000	10,000	9,900	18,000	20,700	918	1,630	2,000	4.2	7.2	9.0	

- Note :**
- Cooling Capacity is based on : indoor temp.27°CDB, 19°CWB  
: outdoor temp. 35°CDB
  - The total ability of connected a indoor unit is up to 30kBtu/h
  - At least two indoor units should be connected.

## Models : A3UQ24GFD0

### Cooling

Operation	Combination (kBtu/h)				Each Capacity (Btu/h)			Total Capacity (Btu/h)			Total Input (W)			Total Current (A)		
	Unit-A	Unit-B	Unit-C	Total	Unit-A	Unit-B	Unit-C	Min	Rated	Max	Min	Rated	Max	Min	Rated	Max
1 UNIT	9	-	-	9	9,000	-	-	4,950	9,000	10,800	470	780	1,020	2.1	3.5	4.6
	12	-	-	12	12,000	-	-	6,600	12,000	14,400	542	900	1,310	2.4	4.1	5.9
	18	-	-	18	18,000	-	-	9,900	18,000	21,600	981	1,630	2,000	4.5	7.2	9.0
	24	-	-	24	24,000	-	-	13,200	24,000	26,400	1,282	2,130	2,800	5.8	9.5	12.0
2 UNIT	9	9	-	18	9,000	9,000	-	9,900	18,000	21,600	981	1,630	2,000	4.5	7.2	9.0
	9	12	-	21	9,000	12,000	-	11,550	21,000	25,200	1,132	1,880	2,100	5.1	7.2	9.0
	9	18	-	27	8,000	16,000	-	13,200	24,000	26,400	1,282	2,130	2,800	5.8	9.5	12.0
	9	24	-	33	6,545	17,455	-	13,200	24,000	26,400	1,282	2,130	2,800	5.8	9.5	12.0
	12	12	-	24	12,000	12,000	-	13,200	24,000	26,400	1,282	2,130	2,800	5.8	9.5	12.0
	12	18	-	30	9,600	14,400	-	13,200	24,000	26,400	1,282	2,130	2,800	5.8	9.5	12.0
3 UNIT	9	9	9	27	8,000	8,000	8,000	13,200	24,000	26,400	1,282	2,130	2,800	5.8	9.5	12.0
	9	9	12	30	7,200	7,200	9,600	13,200	24,000	26,400	1,282	2,130	2,800	5.8	9.5	12.0
	9	12	12	33	6,545	8,727	8,727	13,200	24,000	26,400	1,282	2,130	2,800	5.8	9.5	12.0

- Note :**
- Cooling Capacity is based on : indoor temp.27°CDB, 19°CWB  
: outdoor temp. 35°CDB
  - The total ability of connected a indoor unit is up to 34kBtu/h
  - At least two indoor units should be connected.

## Models : A3UQ30GFD0

### Cooling

Operation	Combination (kBtu/h)				Each Capacity (Btu/h)			Total Capacity (Btu/h)			Total Input (W)			Total Current (A)		
	Unit-A	Unit-B	Unit-C	Total	Unit-A	Unit-B	Unit-C	Min	Rated	Max	Min	Rated	Max	Min	Rated	Max
1 UNIT	9	-	-	9	9,000	-	-	7,100	9,000	10,800	680	880	1,050	3.2	3.9	4.6
	12	-	-	12	12,000	-	-	10,340	12,000	13,700	830	930	1,320	3.8	4.1	5.8
	18	-	-	18	18,000	-	-	15,180	18,000	21,700	1,200	1,410	2,230	5.6	6.1	9.8
	24	-	-	24	24,000	-	-	18,860	24,000	26,900	1,480	1,850	2,510	6.7	8.1	11.0
2 UNIT	9	9	-	18	9,000	9,000	-	15,180	18,000	21,700	1,200	1,410	2,230	5.6	6.1	9.8
	9	12	-	21	9,000	12,000	-	17,020	21,000	24,300	1,340	1,630	2,370	6.0	7.2	10.5
	9	18	-	27	9,000	18,000	-	20,700	27,000	29,300	1,615	2,275	2,705	7.2	10.1	12.0
	9	24	-	33	8,182	21,818	-	22,540	30,000	31,800	1,917	2,700	2,900	8.5	11.5	12.9
	12	12	-	24	12,000	12,000	-	18,860	24,000	26,900	1,480	1,850	2,510	6.7	8.1	11.0
	12	18	-	30	12,000	18,000	-	22,540	30,000	31,800	1,917	2,700	2,900	8.5	11.5	12.9
	12	24	-	36	10,000	20,000	-	22,540	30,000	31,800	1,917	2,700	2,900	8.5	11.5	12.9
	18	18	-	36	15,000	15,000	-	22,540	30,000	31,800	1,917	2,700	2,900	8.5	11.5	12.9
	18	24	-	42	12,857	17,143	-	22,540	30,000	31,800	1,917	2,700	2,900	8.5	11.5	12.9
	3 UNIT	9	9	9	27	9,000	9,000	9,000	20,700	27,000	29,300	1,615	2,275	2,705	7.2	10.1
9		9	12	30	9,000	9,000	12,000	22,540	30,000	31,800	1,917	2,700	2,900	8.5	11.5	12.9
9		9	18	36	7,500	7,500	15,000	22,540	30,000	31,800	1,917	2,700	2,900	8.5	11.5	12.9
9		9	24	42	6,429	6,429	17,143	22,540	30,000	31,800	1,917	2,700	2,900	8.5	11.5	12.9
9		12	12	33	8,182	10,909	10,909	22,540	30,000	31,800	1,917	2,700	2,900	8.5	11.5	12.9
9		12	18	39	6,923	9,231	13,846	22,540	30,000	31,800	1,917	2,700	2,900	8.5	11.5	12.9
12		12	12	36	10,000	10,000	10,000	22,540	30,000	31,800	1,917	2,700	2,900	8.5	11.5	12.9
12		12	18	42	8,571	8,571	12,857	22,540	30,000	31,800	1,917	2,700	2,900	8.5	11.5	12.9

- Note :**
- Cooling Capacity is based on : indoor temp.27°CDB, 19°CWB  
: outdoor temp. 35°CDB
  - The total ability of connected a indoor unit is up to 42kBtu/h
  - At least two indoor units should be connected.

# OUTDOOR UNITS

**Models : A4UQ36GFD0**

**Cooling**

Operation	Combination (kBtu/h)					Each Capacity (Btu/h)				Total Capacity (Btu/h)			Total Input (W)			Total Current (A)		
	Unit-A	Unit-B	Unit-C	Unit-D	Total	Unit-A	Unit-B	Unit-C	Unit-D	Min	Rated	Max	Min	Rated	Max	Min	Rated	Max
1 UNIT	9	-	-	-	9	9,000	-	-	-	7,100	9,000	10,800	680	880	1,050	3.2	3.9	4.6
	12	-	-	-	12	12,000	-	-	-	10,340	12,000	13,700	830	930	1,320	3.8	4.1	5.8
	18	-	-	-	18	18,000	-	-	-	15,180	18,000	21,700	1,200	1,410	2,230	5.6	6.1	9.8
	24	-	-	-	24	24,000	-	-	-	18,860	24,000	26,900	1,480	1,850	2,510	6.7	8.1	11.0
2 UNIT	9	9	-	-	18	9,000	9,000	-	-	15,180	18,000	21,700	1,200	1,410	2,230	5.6	6.1	9.8
	9	12	-	-	21	9,000	12,000	-	-	17,020	21,000	24,300	1,340	1,630	2,370	6.0	7.2	10.5
	9	18	-	-	27	9,000	18,000	-	-	20,700	27,000	29,300	1,615	2,275	2,705	7.2	10.1	12.0
	9	24	-	-	33	9,000	24,000	-	-	24,380	33,000	35,900	2,059	2,900	3,325	9.4	12.7	14.9
	12	12	-	-	24	12,000	12,000	-	-	18,860	24,000	26,900	1,480	1,850	2,510	6.7	8.1	11.0
	12	18	-	-	30	12,000	18,000	-	-	22,540	30,000	31,800	1,917	2,700	2,900	8.5	11.5	12.9
	12	24	-	-	36	12,000	24,000	-	-	26,220	36,000	40,000	2,201	3,100	3,750	10.3	14.0	17.0
	18	18	-	-	36	18,000	18,000	-	-	26,220	36,000	40,000	2,201	3,100	3,750	10.3	14.0	17.0
	18	24	-	-	42	15,429	20,571	-	-	26,220	36,000	40,000	2,201	3,100	3,750	10.3	14.0	17.0
3 UNIT	9	9	9	-	27	9,000	9,000	9,000	-	20,700	27,000	29,300	1,615	2,275	2,705	7.2	10.1	12.0
	9	9	12	-	30	9,000	9,000	12,000	-	22,540	30,000	31,800	1,917	2,700	2,900	8.5	11.5	12.9
	9	9	18	-	36	9,000	9,000	18,000	-	26,220	36,000	40,000	2,201	3,100	3,750	10.3	14.0	17.0
	9	9	24	-	42	7,714	7,714	20,571	-	26,220	36,000	40,000	2,201	3,100	3,750	10.3	14.0	17.0
	9	12	12	-	33	9,000	12,000	12,000	-	24,380	33,000	35,900	2,059	2,900	3,325	9.4	12.7	14.9
	9	12	18	-	39	8,308	11,077	16,615	-	26,220	36,000	40,000	2,201	3,100	3,750	10.3	14.0	17.0
	9	12	24	-	45	7,200	9,600	19,200	-	26,220	36,000	40,000	2,201	3,100	3,750	10.3	14.0	17.0
	9	18	18	-	45	7,200	14,400	14,400	-	26,220	36,000	40,000	2,201	3,100	3,750	10.3	14.0	17.0
	12	12	12	-	36	12,000	12,000	12,000	-	26,220	36,000	40,000	2,201	3,100	3,750	10.3	14.0	17.0
	12	12	18	-	42	10,286	10,286	15,429	-	26,220	36,000	40,000	2,201	3,100	3,750	10.3	14.0	17.0
	12	12	24	-	48	9,000	9,000	18,000	-	26,220	36,000	40,000	2,201	3,100	3,750	10.3	14.0	17.0
	12	18	18	-	48	9,000	13,500	13,500	-	26,220	36,000	40,000	2,201	3,100	3,750	10.3	14.0	17.0
4 UNIT	9	9	9	9	36	9,000	9,000	9,000	9,000	26,220	36,000	40,000	2,201	3,100	3,750	10.3	14.0	17.0
	9	9	9	12	39	8,308	8,308	8,308	11,077	26,220	36,000	40,000	2,201	3,100	3,750	10.3	14.0	17.0
	9	9	9	18	45	7,200	7,200	7,200	14,400	26,220	36,000	40,000	2,201	3,100	3,750	10.3	14.0	17.0
	9	9	12	12	42	7,714	7,714	10,286	10,286	26,220	36,000	40,000	2,201	3,100	3,750	10.3	14.0	17.0
	9	9	12	18	48	6,750	6,750	9,000	13,500	26,220	36,000	40,000	2,201	3,100	3,750	10.3	14.0	17.0
	9	12	12	12	45	7,200	9,600	9,600	9,600	26,220	36,000	40,000	2,201	3,100	3,750	10.3	14.0	17.0
	12	12	12	12	48	9,000	9,000	9,000	9,000	26,220	36,000	40,000	2,201	3,100	3,750	10.3	14.0	17.0

**Note :**

- Cooling Capacity is based on : indoor temp.27°CDB, 19°CWB  
: outdoor temp. 35°CDB
- The total ability of connected a indoor unit is up to 50kBtu/h
- At least two indoor units should be connected.

**Models : A5UQ48GFA1**

**Cooling**

Operation	Combination (kBtu/h)						Each Capacity (Btu/h)					Total Capacity (Btu/h)			Total Input (W)			Total Current (A)		
	Unit-A	Unit-B	Unit-C	Unit-D	Unit-E	Total	Unit-A	Unit-B	Unit-C	Unit-D	Unit-E	Min	Rated	Max	Min	Rated	Max	Min	Rated	Max
1 UNIT	9	-	-	-	-	9	9,000	-	-	-	7,000	9,000	10,800	600	750	970	2.7	3.4	4.4	
	12	-	-	-	-	12	12,000	-	-	-	7,500	12,000	14,400	630	1,010	1,850	2.9	4.6	8.4	
	18	-	-	-	-	18	18,000	-	-	-	10,800	18,000	21,600	1,040	1,690	2,750	4.7	7.7	12.5	
	24	-	-	-	-	24	24,000	-	-	-	12,400	24,000	28,800	1,140	2,550	3,410	5.2	11.5	15.4	
2 UNIT	9	9	-	-	-	18	9,000	9,000	-	-	13,206	18,000	25,941	1,190	1,590	3,020	5.4	7.2	13.7	
	9	12	-	-	-	21	9,000	12,000	-	-	14,485	21,000	28,147	1,350	2,000	3,280	6.1	9.0	14.9	
	12	12	-	-	-	24	12,000	12,000	-	-	15,765	24,000	30,353	1,500	2,400	3,540	6.8	10.9	16.0	
	9	18	-	-	-	27	9,000	18,000	-	-	17,044	27,000	32,559	1,650	2,810	3,810	7.5	12.7	17.2	
	12	18	-	-	-	30	12,000	18,000	-	-	18,324	30,000	34,765	1,800	3,210	4,070	8.2	14.5	18.4	
	9	24	-	-	-	33	9,000	24,000	-	-	19,603	33,000	36,971	1,950	3,620	4,330	8.8	16.4	19.6	
	12	24	-	-	-	36	12,000	24,000	-	-	20,882	36,000	39,176	2,110	4,020	4,590	9.5	18.2	20.8	
	18	18	-	-	-	36	18,000	18,000	-	-	20,882	36,000	39,176	2,110	4,020	4,590	9.5	18.2	20.8	
	18	24	-	-	-	42	18,000	24,000	-	-	23,441	42,000	43,588	2,410	4,830	5,120	10.9	21.9	23.2	
3 UNIT	9	9	9	-	-	27	8,588	8,588	8,588	-	19,224	25,765	35,088	1,740	2,290	4,010	7.9	10.4	18.2	
	9	9	12	-	-	30	8,444	8,444	11,259	-	20,335	28,147	36,632	1,860	2,590	4,180	8.4	11.8	18.9	
	9	12	12	-	-	33	8,326	11,102	11,102	-	21,447	30,529	38,176	1,990	2,900	4,350	9.0	13.1	19.7	
	9	9	18	-	-	36	8,228	8,228	16,456	-	22,559	32,912	39,721	2,110	3,210	4,520	9.6	14.5	20.5	
	12	12	12	-	-	36	10,971	10,971	10,971	-	22,559	32,912	39,721	2,110	3,210	4,520	9.6	14.5	20.5	
	9	12	18	-	-	39	8,145	10,860	16,290	-	23,671	35,294	41,265	2,240	3,510	4,690	10.1	15.9	21.2	
	9	9	24	-	-	42	8,074	8,074	21,529	-	24,782	37,676	42,809	2,370	3,820	4,860	10.7	17.3	22.0	
	12	12	18	-	-	42	10,765	10,765	16,147	-	24,782	37,676	42,809	2,370	3,820	4,860	10.7	17.3	22.0	
	9	12	24	-	-	45	8,012	10,682	21,365	-	25,894	40,059	44,353	2,490	4,130	5,030	11.3	18.7	22.8	
	9	18	18	-	-	45	8,012	16,024	16,024	-	25,894	40,059	44,353	2,490	4,130	5,030	11.3	18.7	22.8	
	12	12	24	-	-	48	12,000	12,000	24,000	-	29,600	48,000	49,500	2,910	5,150	5,590	13.2	23.3	25.3	
	12	18	18	-	-	48	12,000	18,000	18,000	-	29,600	48,000	49,500	2,910	5,150	5,590	13.2	23.3	25.3	
	9	18	24	-	-	51	8,471	16,941	22,588	-	29,600	48,000	49,500	2,910	5,150	5,590	13.2	23.3	25.3	
	12	18	24	-	-	54	10,667	16,000	21,333	-	29,600	48,000	49,500	2,910	5,150	5,590	13.2	23.3	25.3	
	18	18	18	-	-	54	16,000	16,000	16,000	-	29,600	48,000	49,500	2,910	5,150	5,590	13.2	23.3	25.3	
	9	24	24	-	-	57	7,579	20,211	20,211	-	29,600	48,000	49,500	2,910	5,150	5,590	13.2	23.3	25.3	
12	24	24	-	-	60	9,600	19,200	19,200	-	29,600	48,000	49,500	2,910	5,150	5,590	13.2	23.3	25.3		
18	18	24	-	-	60	14,400	14,400	19,200	-	29,600	48,000	49,500	2,910	5,150	5,590	13.2	23.3	25.3		
18	24	24	-	-	66	13,091	17,455	17,455	-	29,600	48,000	49,500	2,910	5,150	5,590	13.2	23.3	25.3		
24	24	24	-	-	72	16,000	16,000	16,000	-	29,600	48,000	49,500	2,910	5,150	5,590	13.2	23.3	25.3		

**Note :**

- Cooling Capacity is based on : indoor temp.27°CDB, 19°CWB  
: outdoor temp. 35°CDB
- The total ability of connected a indoor unit is up to 50kBtu/h
- At least two indoor units should be connected.



# OUTDOOR UNITS

## Models : A5UQ48GFA1

### Cooling

Operation	Combination (kBtu/h)						Each Capacity (Btu/h)					Total Capacity (Btu/h)			Total Input (W)			Total Current (A)		
	Unit-A	Unit-B	Unit-C	Unit-D	Unit-E	Total	Unit-A	Unit-B	Unit-C	Unit-D	Unit-E	Min	Rated	Max	Min	Rated	Max	Min	Rated	Max
4 UNIT	9	9	9	9	-	36	9,000	9,000	9,000	9,000	-	25,900	36,000	45,300	2,380	3,320	5,010	10.8	15.0	22.7
	9	9	9	12	-	39	9,000	9,000	9,000	12,000	-	27,175	39,000	46,725	2,520	3,710	5,150	11.4	16.8	23.3
	9	9	12	12	-	42	9,000	9,000	12,000	12,000	-	28,450	42,000	48,150	2,670	4,110	5,280	12.1	18.6	23.9
	9	12	12	12	-	45	9,000	12,000	12,000	12,000	-	29,725	45,000	49,575	2,810	4,500	5,410	12.7	20.4	24.5
	9	9	9	18	-	45	9,000	9,000	9,000	18,000	-	29,725	45,000	49,575	2,810	4,500	5,410	12.7	20.4	24.5
	9	9	12	18	-	48	9,000	9,000	12,000	18,000	-	31,000	48,000	51,000	2,950	4,900	5,550	13.4	22.2	25.1
	12	12	12	12	-	48	12,000	12,000	12,000	12,000	-	31,000	48,000	51,000	2,950	4,900	5,550	13.4	22.2	25.1
	9	9	9	24	-	51	8,471	8,471	8,471	22,588	-	31,000	48,000	51,000	2,950	4,900	5,550	13.4	22.2	25.1
	9	12	12	18	-	51	8,471	11,294	11,294	16,941	-	31,000	48,000	51,000	2,950	4,900	5,550	13.4	22.2	25.1
	9	9	12	24	-	54	8,000	8,000	10,667	21,333	-	31,000	48,000	51,000	2,950	4,900	5,550	13.4	22.2	25.1
	9	9	18	18	-	54	8,000	8,000	16,000	16,000	-	31,000	48,000	51,000	2,950	4,900	5,550	13.4	22.2	25.1
	12	12	12	18	-	54	10,667	10,667	10,667	16,000	-	31,000	48,000	51,000	2,950	4,900	5,550	13.4	22.2	25.1
	9	12	12	24	-	57	7,579	10,105	10,105	20,211	-	31,000	48,000	51,000	2,950	4,900	5,550	13.4	22.2	25.1
	9	12	18	18	-	57	7,579	10,105	15,158	15,158	-	31,000	48,000	51,000	2,950	4,900	5,550	13.4	22.2	25.1
	9	9	18	24	-	60	7,200	7,200	14,400	19,200	-	31,000	48,000	51,000	2,950	4,900	5,550	13.4	22.2	25.1
	12	12	12	24	-	60	9,600	9,600	9,600	19,200	-	31,000	48,000	51,000	2,950	4,900	5,550	13.4	22.2	25.1
	12	12	18	18	-	60	9,600	9,600	14,400	14,400	-	31,000	48,000	51,000	2,950	4,900	5,550	13.4	22.2	25.1
	9	12	18	24	-	63	6,857	9,143	13,714	18,286	-	31,000	48,000	51,000	2,950	4,900	5,550	13.4	22.2	25.1
	9	18	18	18	-	63	6,857	13,714	13,714	13,714	-	31,000	48,000	51,000	2,950	4,900	5,550	13.4	22.2	25.1
	9	9	24	24	-	66	6,545	6,545	17,455	17,455	-	31,000	48,000	51,000	2,950	4,900	5,550	13.4	22.2	25.1
12	12	18	24	-	66	8,727	8,727	13,091	17,455	-	31,000	48,000	51,000	2,950	4,900	5,550	13.4	22.2	25.1	
12	18	18	18	-	66	8,727	13,091	13,091	13,091	-	31,000	48,000	51,000	2,950	4,900	5,550	13.4	22.2	25.1	
9	12	24	24	-	69	6,261	8,348	16,696	16,696	-	31,000	48,000	51,000	2,950	4,900	5,550	13.4	22.2	25.1	
9	18	18	24	-	69	6,261	12,522	12,522	16,696	-	31,000	48,000	51,000	2,950	4,900	5,550	13.4	22.2	25.1	
12	12	24	24	-	72	8,000	8,000	16,000	16,000	-	31,000	48,000	51,000	2,950	4,900	5,550	13.4	22.2	25.1	
12	18	18	24	-	72	8,000	12,000	12,000	16,000	-	31,000	48,000	51,000	2,950	4,900	5,550	13.4	22.2	25.1	
18	18	18	18	-	72	12,000	12,000	12,000	12,000	-	31,000	48,000	51,000	2,950	4,900	5,550	13.4	22.2	25.1	

- Note :**
- Cooling Capacity is based on : indoor temp.27°CDB, 19°CWB  
: outdoor temp. 35°CDB
  - The total ability of connected a indoor unit is up to 50kBtu/h
  - At least two indoor units should be connected.

## Models : A5UQ48GFA1

### Cooling

Operation	Combination (kBtu/h)						Each Capacity (Btu/h)					Total Capacity (Btu/h)			Total Input (W)			Total Current (A)		
	Unit-A	Unit-B	Unit-C	Unit-D	Unit-E	Total	Unit-A	Unit-B	Unit-C	Unit-D	Unit-E	Min	Rated	Max	Min	Rated	Max	Min	Rated	Max
5 UNIT	9	9	9	9	9	45	9,000	9,000	9,000	9,000	9,000	31,808	45,000	51,808	2,970	4,010	5,400	13.0	17.6	23.7
	9	9	9	9	12	48	9,000	9,000	9,000	9,000	12,000	34,000	48,000	52,800	3,180	4,400	5,460	13.8	19.2	23.7
	9	9	9	12	12	51	8,471	8,471	8,471	11,294	11,294	34,000	48,000	52,800	3,180	4,400	5,460	13.8	19.2	23.7
	9	9	9	9	18	54	8,000	8,000	8,000	8,000	16,000	34,000	48,000	52,800	3,180	4,400	5,460	13.8	19.2	23.7
	9	9	12	12	12	54	8,000	8,000	10,667	10,667	10,667	34,000	48,000	52,800	3,180	4,400	5,460	13.8	19.2	23.7
	9	9	9	12	12	57	7,579	7,579	7,579	10,105	15,158	34,000	48,000	52,800	3,180	4,400	5,460	13.8	19.2	23.7
	9	12	12	12	12	57	7,579	10,105	10,105	10,105	10,105	34,000	48,000	52,800	3,180	4,400	5,460	13.8	19.2	23.7
	9	9	9	9	24	60	7,200	7,200	7,200	7,200	19,200	34,000	48,000	52,800	3,180	4,400	5,460	13.8	19.2	23.7
	9	9	12	12	18	60	7,200	7,200	9,600	9,600	14,400	34,000	48,000	52,800	3,180	4,400	5,460	13.8	19.2	23.7
	12	12	12	12	12	60	9,600	9,600	9,600	9,600	9,600	34,000	48,000	52,800	3,180	4,400	5,460	13.8	19.2	23.7
	9	9	9	12	24	63	6,857	6,857	6,857	9,143	18,286	34,000	48,000	52,800	3,180	4,400	5,460	13.8	19.2	23.7
	9	9	9	18	18	63	6,857	6,857	6,857	13,714	13,714	34,000	48,000	52,800	3,180	4,400	5,460	13.8	19.2	23.7
	9	12	12	12	18	63	6,857	9,143	9,143	9,143	13,714	34,000	48,000	52,800	3,180	4,400	5,460	13.8	19.2	23.7
	9	9	12	12	24	66	6,545	6,545	8,727	8,727	17,455	34,000	48,000	52,800	3,180	4,400	5,460	13.8	19.2	23.7
	9	9	12	18	18	66	6,545	6,545	8,727	13,091	13,091	34,000	48,000	52,800	3,180	4,400	5,460	13.8	19.2	23.7
	12	12	12	12	18	66	8,727	8,727	8,727	8,727	13,091	34,000	48,000	52,800	3,180	4,400	5,460	13.8	19.2	23.7
	9	9	9	18	24	69	6,261	6,261	6,261	12,522	16,696	34,000	48,000	52,800	3,180	4,400	5,460	13.8	19.2	23.7
	9	12	12	12	24	69	6,261	8,348	8,348	8,348	16,696	34,000	48,000	52,800	3,180	4,400	5,460	13.8	19.2	23.7
	9	12	12	18	18	69	6,261	8,348	8,348	12,522	12,522	34,000	48,000	52,800	3,180	4,400	5,460	13.8	19.2	23.7
	9	9	12	18	24	72	6,000	6,000	8,000	12,000	16,000	34,000	48,000	52,800	3,180	4,400	5,460	13.8	19.2	23.7
9	9	18	18	18	72	6,000	6,000	12,000	12,000	12,000	34,000	48,000	52,800	3,180	4,400	5,460	13.8	19.2	23.7	
12	12	12	12	24	72	8,000	8,000	8,000	8,000	16,000	34,000	48,000	52,800	3,180	4,400	5,460	13.8	19.2	23.7	
12	12	12	18	18	72	8,000	8,000	8,000	12,000	12,000	34,000	48,000	52,800	3,180	4,400	5,460	13.8	19.2	23.7	

- Note :**
- Cooling Capacity is based on : indoor temp.27°CDB, 19°CWB  
: outdoor temp. 35°CDB
  - The total ability of connected a indoor unit is up to 50kBtu/h
  - At least two indoor units should be connected.

# INDOOR UNIT

KEY FEATURES

SPECIFICATION



# FAST & COMFORT COOLING

## 4-Way Swing

Cool air reaches out to the entire room regardless of where the air conditioner is installed

\* Specifications may vary for each model.

\* Specifications may vary for each model.

### • How It Works

#### 6-Step Vane, Control up to 70°

The vertical vane, which moves up and down, has 6 different settings including full-auto swing.

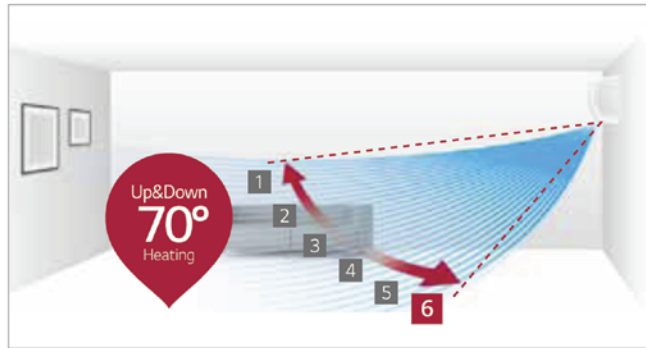

\* Angle can be different from each model and working mode.

#### 5-Step Louver, Control up to 55°

The louver, which sways left and right, has 5 different settings including full auto-swing.

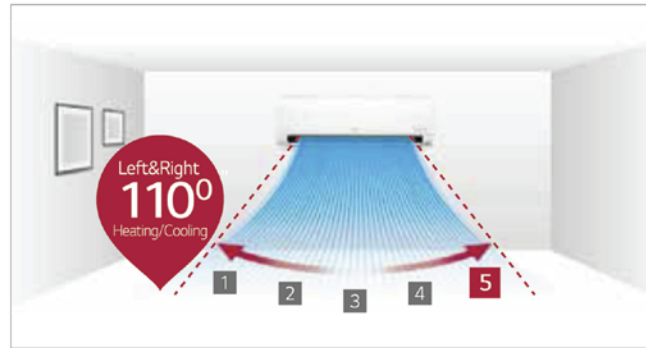

### • Easy and Simple Control

Airflow direction can be changed by LG ThinQ Wi-Fi app.

#### Up/Down Swing

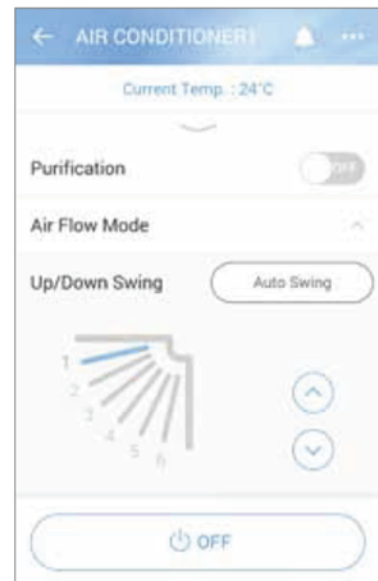

#### Left/Right Swing

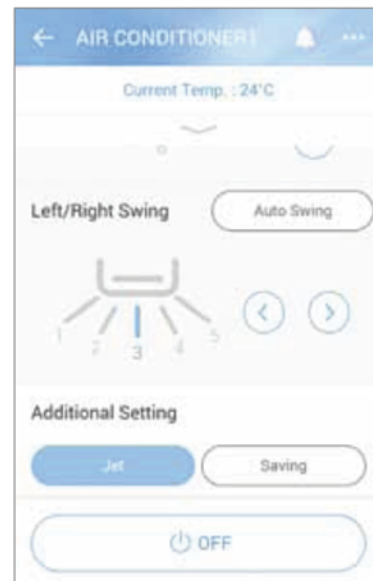

## Jet Cool

LG air conditioners provide optimized high-speed airflow, which can cool rooms faster while delivering cool air evenly in every direction.

\* Specifications may vary for each model.

\* Depending on the experimental conditions.

### • How It Works

#### One Click "Jet Mode"

Reduces the temperature of outflowing air to 18°C for 30 minutes with just one click.

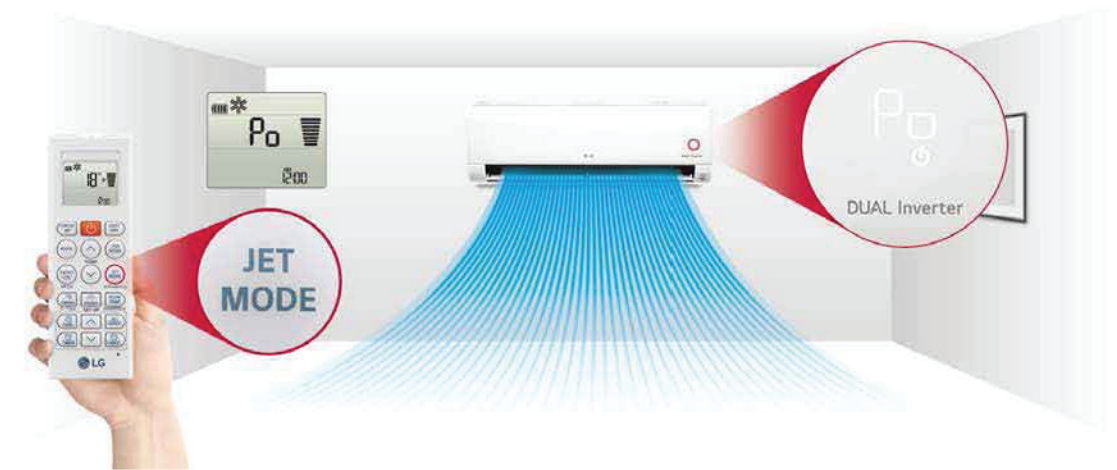

### • More Powerful Performance

By reducing the second vortex, which decreases airflow within the air outlet, and enlarging the fan size, the amount of airflow is increased to 13.0 CMM.



# COMFORT

## Comfort Air

LG provides pure hygienic and temperature regulated atmosphere surrounding your living space. An automatic vane angle adjustment sets perfect vane angle and air volume.

\* Specifications may vary for each model.

### • Concept

If the air conditioner remains ON while asleep, it can lower body temperature or cause discomfort, especially if the outflow of cool air is directly close to the room's occupants. This can be eliminated by the Comfort Air vane angle thus providing a comfortable environment to the sleeping occupants.

### • How It Works

Control Panel

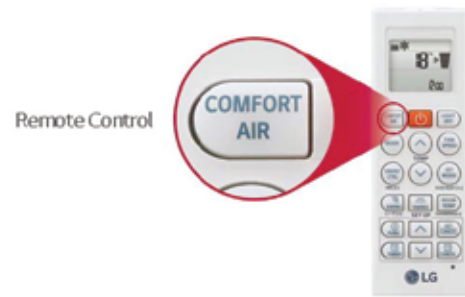

### Comfort Vane

This option conveniently sets an AC's louvers to a preset position so that outflowing air is directed away from a room's occupants.

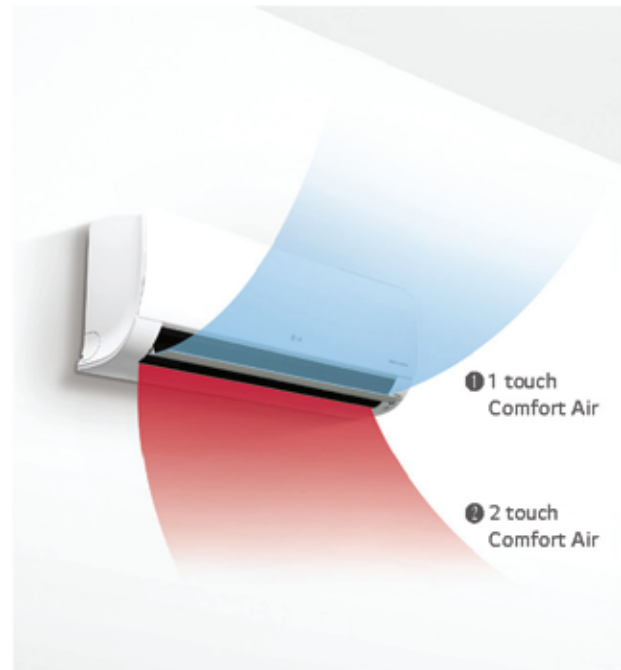

Scene 1: Inclines to a maximum 70° angle.  
Sets vane angle to highest position : Optimized for gentle airflow cooling.

Indoor Unit Display



Remote Controller Display



Scene 2: Declines to a maximum 0° angle.  
Sets vane angle to lowest position : Optimized for gentle airflow heating.

Indoor Unit Display



Remote Controller Display



## Quick and Easy Installation

LG air conditioner is designed for an easy and efficient installation, making possible to install several units in a short period of time

\* Specifications may vary for each model.

### • Concept

By reducing the manpower and time required for installation, it is now possible to install more units in less time.

### • How It Works

One Simple Packing Box

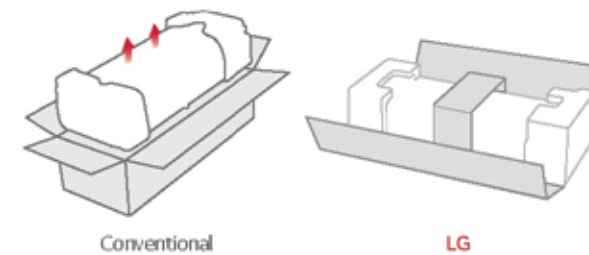

Installation Plate Improvement

LG's installation plate is larger and customized to reduce installation time.

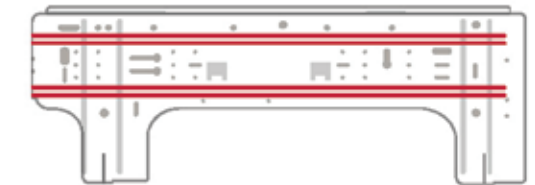

Installation Support Clip

A support clip creates adequate space between the wall and the unit for easier installation.

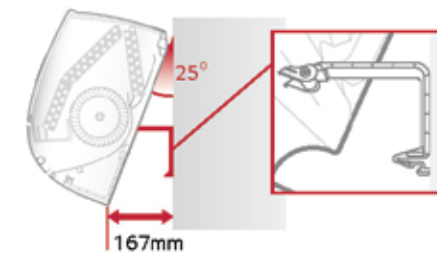

Wider Tubing Space

The space provided for tubing facilitates the whole installation process and hides the unorganized parts, making it appear clean and tidy.

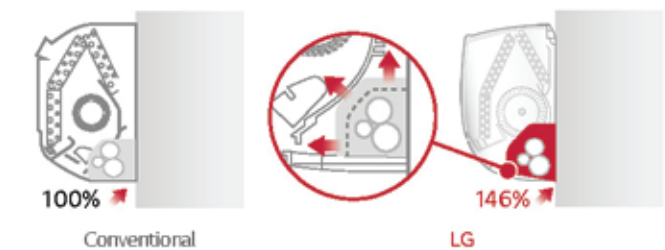

Detachable Bottom Cover

The air conditioner's bottom cover is detachable for easier installation and access.

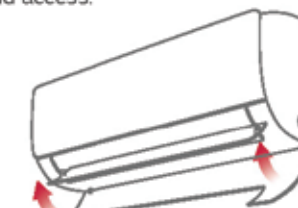

Quick button for running test

The test button is conveniently located and easy to find.

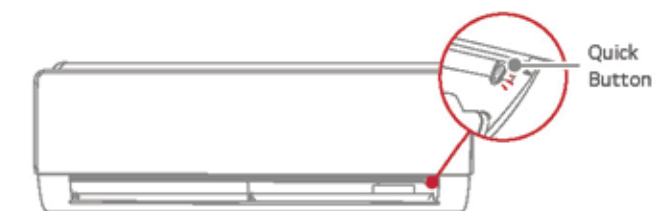

# AIR PURIFYING

## Dual Protection Filter

The Dual Protection Filter collects dust.

\* Specifications may vary for each model.  
\* Depending on the experimental conditions.

### • What is the Dual Protection Filter?

The Dual Protection Filter, designed to capture dust particles over 10µm in size, is the first line of defense and hindrance against finer particles.



### • Additional Benefit

#### Easy to Open

Easily detachable full surface cover helps clean the air conditioner flawlessly.



#### Easy to Clean

The filter is designed for easy handling and quick cleaning, which lengthens its lifespan.



## Auto Cleaning

The interior of the air conditioner is maintained clean by drying off the heat exchanger, then sterilizing the interior once more.

\* Specifications may vary for each model.

### • Pain Point

The main cause of odor within air conditioners is mold and bacteria growing on the heat exchanger. These germs can spread when the heat exchanger is wet.



### • How It Works

#### Cleans Filter with Regular Airflow

The comprehensive auto cleaning function prevents the formation of bacteria and mold on the heat exchanger, providing an enhancing environment.

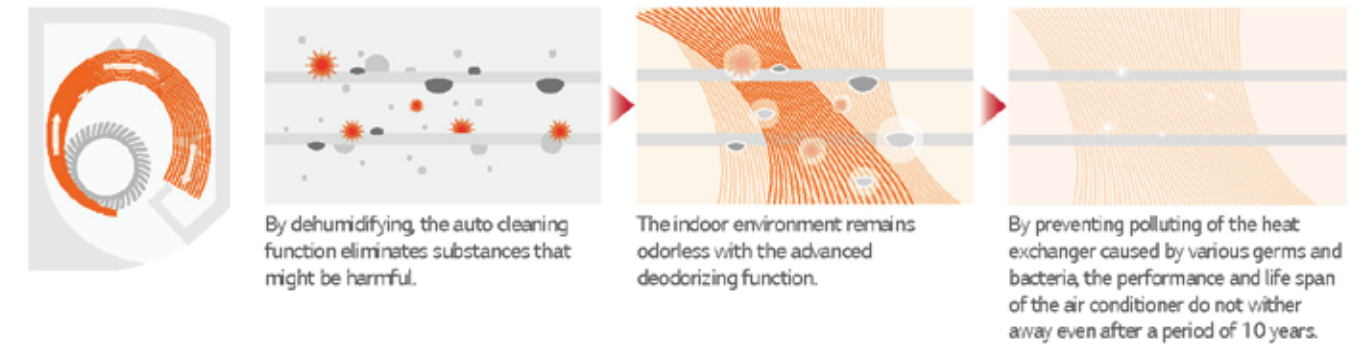

### • Benefit

#### Removes Harmful Particles

Auto Cleaning provides clean air by preventing bacteria, mold and odors that can otherwise accumulate in an indoor unit.



# SMART

## Embedded Wi-Fi

• **Benefit**

**Integrated Home Appliances Control**

Control / Monitor all your LG appliances from one place.



Access your air conditioner anytime and from anywhere with a Wi-Fi equipped device and LG's exclusive control app, Smart ThinQ.



## E.S.P. (External Static Pressure) Control

E.S.P. control function can make air volume controlled easily with remote controller. The BLDC motor can control fan speed and air volume regardless of the external static pressure. No additional accessories are necessary to control air flow.

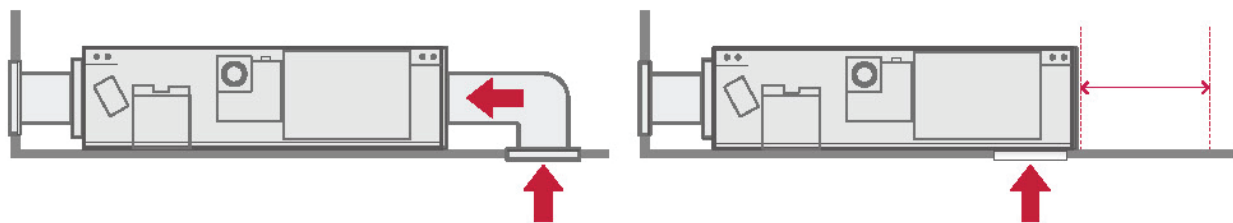

## Embedded Wi-Fi

Control your air conditioners by using Android or iOS based smartphones. This advanced technology provides you many benefits.

• **LG ThinQ**



LG ThinQ

Download the 'LG ThinQ' app from the Google Downloads or the Appstore



• **How it Works**

**Embedded Wi-Fi modem**

Enable "LG Smart ThinQ" on your air conditioner.



By using the embedded Wi-Fi modem, get ready for innovation without boundaries.



**Easy Registration and Log-in**

Follow the interactive set-up LG Account steps that will activate smart ThinQ's impressive features.

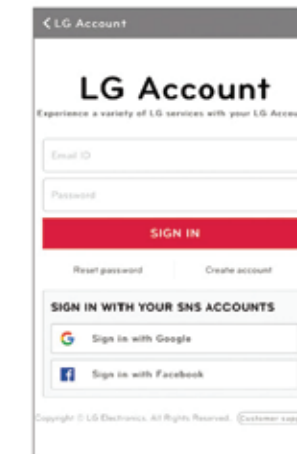

**Wi-Fi Connectivity**

Each individual member of your family can customise the air conditioner temperature and fan speed accordingly and then save the settings in their app to run it later. These settings can be saved for each air conditioner too.

**Multiple Devices**



**Multi-Control**



# NETWORK FUNCTION

## Dry Contact

### • With Home Network System

Interlocking with home network system enables various application. Depending on building size and usage, various communication method can be given.

#### Compatibility to Home Network System

- Basic control (On / Off, Mode, Setting Temp, Fan speed)
- Lock function, Error code

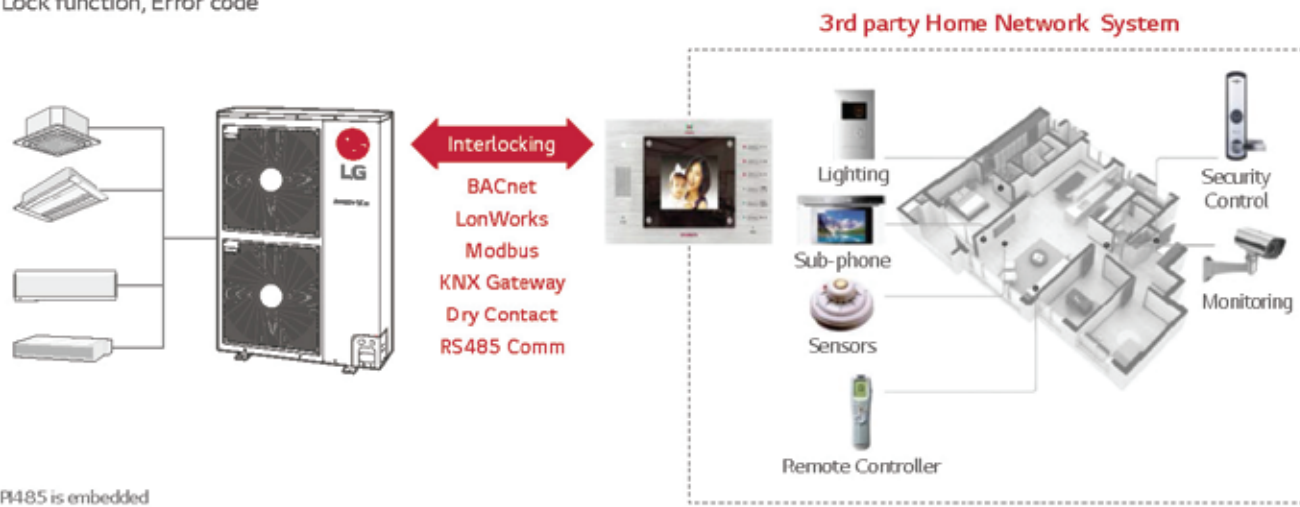

\* B485 is embedded

### • System Flexibility

It can be linked with 3<sup>rd</sup> party BMS via Gateway and provide flexible control system for each site via Dry Contact.

#### Interlock with 3<sup>rd</sup> party BMS



#### Dry Contact optimized for variable scenario



## Network solution

### Advanced Network Accessibility

AC Smart 5 reflects the state of the art of network technology trend. IPv6 (Internet Protocol version 6), which is the most recent version of the Internet Protocol, provides accessibility to the IPv6 compatible network environment. HTML5 makes the web access to AC Smart 5 easier and look good on all devices, especially for mobile.

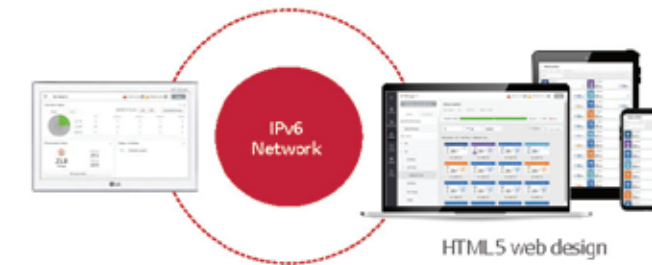

### Visualized Control

Visual navigation enables controlling and monitoring the unit on floor plan view for the intuitive management.



### Energy Management

Energy navigation function allows air conditioners operation to be managed under the monthly plan of energy usage. By analyzing present energy consumption and comparing with the plan, overuse of system operational costs can be prevented.

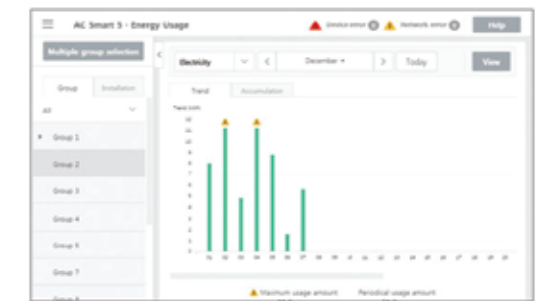

### Device Interlock

Building Facility can be interlocked with LG HVAC system on the automated control logic.

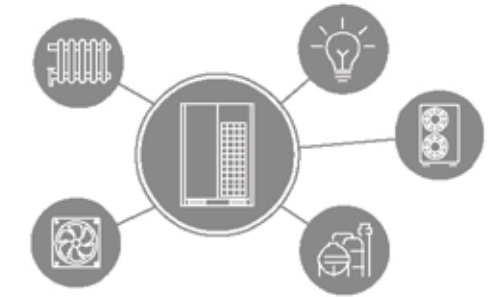

### Operation Trend

Unit's operation status change in the past can be traced to help establishing reasonable operation plan of the site.

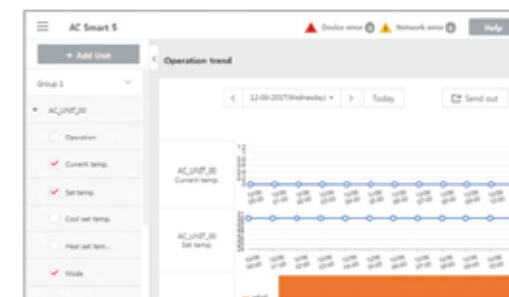

# WALL MOUNTED

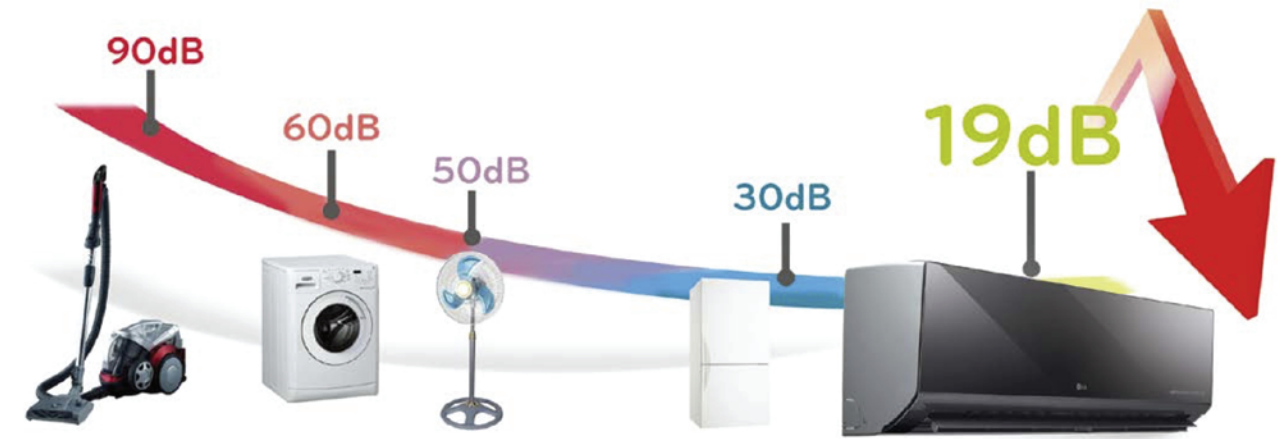

\*Only applicable to 9K and 12K models.

## Superior Design for Quietness

LG Air Conditioners' indoor unit creates natural breeze with minimized noise. Enjoy cool and pleasant living environment with extra quietness.

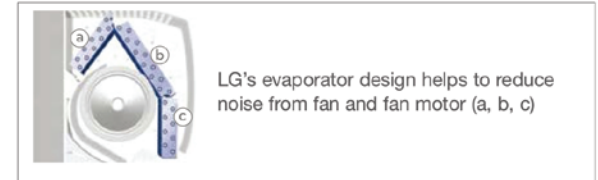

## BLDC Fan Motor

BLDC fan motor offers additional energy saving in operating smoothness.

- Low efficiency
- Heat problem during overhauling

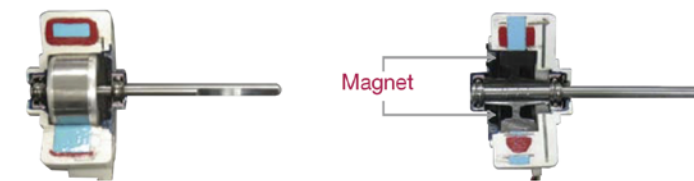

## Skew Fan

LG air conditioner has skew fan, a patent-pending feature that was developed by LG electronics. With tilted blades, skew fan greatly reduced interference with the heat exchanger and achieved extremely quiet cooling.

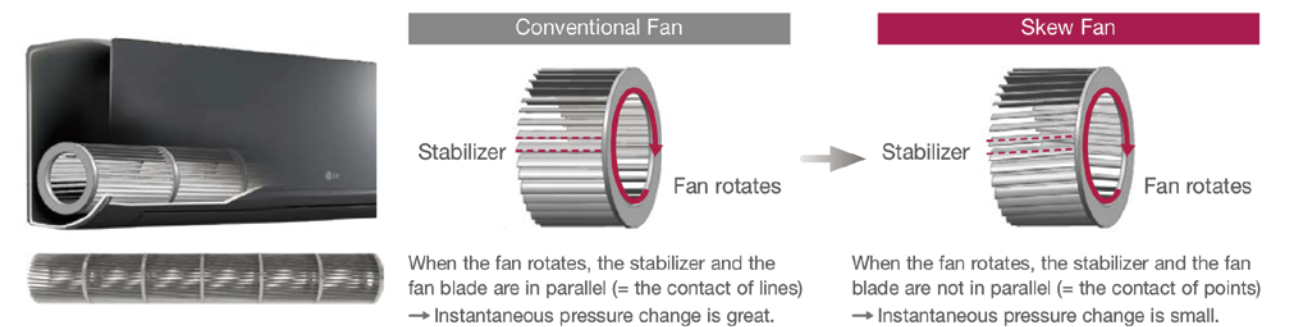



# WALL MOUNTED

## Filtering (Virus & Allergy Safe Filter)

The virus and allergy safe filters are scientifically proven to deactivate viruses that may pose risks to health.

### Virus Deactivation

The LG virus & allergy safe filter blocks neuramidase and hemagglutinin, which is activated when the virus breaks up from host cell to proliferate.

### Allergy Filter

Allergy care filter coated with allergy decomposition substance

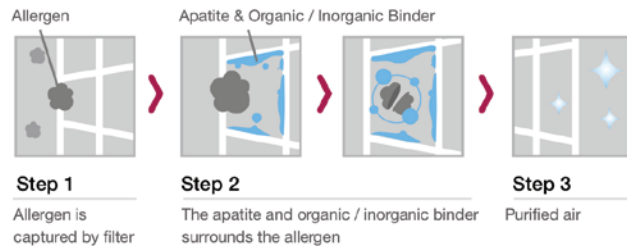

Certified by British Allergy Foundation (2009.01)

### Virus Filter

Sterilising filter with anti-virus coating

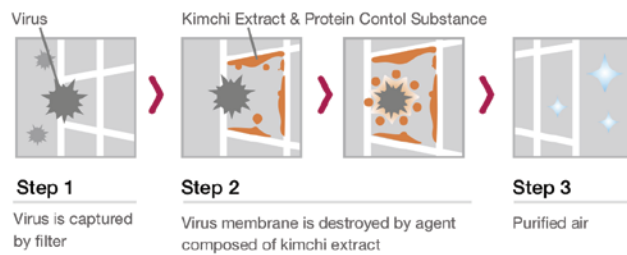

Certified by Kitasato Institute

5-way protection system



NEW ARTCOOL PLATINUM

1. Filtering (Anti Bacterial Prefilter / Anti Allergy Filter / Virus Safe Filter)
2. Deodorizing (Triple filter)
3. Eliminating (Plasma filter)
4. Ionizing
5. Auto Cleaning

4D PROTECTION SYSTEM



Health+

1. Anti Bacterial Prefilter
2. Anti Allergy Filter
3. Deodorizing (Triple filter)
4. Auto Cleaning

## Deodorising (Triple Filter)

The triple filter consists of three special filters that can reduce the side effects caused by some organic compounds including formaldehyde. It has the ability to remove unpleasant odours and can create a more comfortable environment.



- 1 Blue filter removes the chemical smells such as the smell of fresh paint.
- 2 Black filter removes the odour of new buildings such as formaldehyde.
- 3 Red filter removes smells such as smoke and food smells.

## Eliminating (Plasma Filter)

The plasma air purifying system was initially developed by LG not only for reduction of microscopic contaminants and dust, but also for the removal of house mites, small dust particles, and pet fur in order to reduce allergy and asthma symptoms.

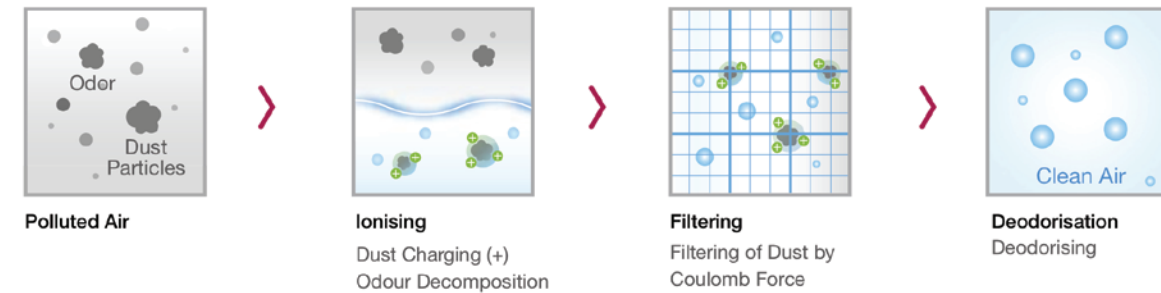

## Ionizing

Discharging plus and negative ions which decompose hazardous substances floating in the air such as molds, germs and allergen, providing fresh and sterilized air to every corner of the house.



## Auto Cleaning

A major cause of air conditioner odours is mould and bacteria that can breed in the heat exchanger. The auto clean function dries the wet heat exchanger to prevent mould and bacteria from breeding which can significantly reduce smells and saves the user from frequent cleaning.

### Conventional

The main causes of odour within air conditioners is mould and bacteria in the heat exchanger, which breeds when the heat exchanger is wet.

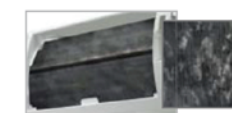

### Auto Cleaning

The automatic cleaning function dries the wet heat exchanger to prevent the bacteria from breeding mould. It eliminates the odour from air conditioners and can reduce the hassle of having to frequently clean the filter.



# WALL MOUNTED

## Wall Mounted Unit (Health plus)



Model Name			AMNC09GDJA0	AMNC12GDJA0	AMNC18GDKA0	AMNC24GDKA0	
Power Supply		V, Ø, Hz	220-240, 1, 50/60	220-240, 1, 50/60	220-240, 1, 50/60	220-240, 1, 50/60	
Power Input	Min./Nom./Max.	W	9 / 18 / 30	9 / 19 / 30	26 / 39 / 60	27 / 45 / 60	
Running Current	Min./Nom./Max.	A	0.12 / 0.16 / 0.20	0.12 / 0.17 / 0.20	0.22 / 0.28 / 0.40	0.24 / 0.33 / 0.40	
Casing Color		-	Munsell 7.5BG 10/2 (RAL 9016)	Munsell 7.5BG 10/2 (RAL 9016)	Munsell 7.5BG 10/2 (RAL 9016)	Munsell 7.5BG 10/2 (RAL 9016)	
Dimensions	Body	W x H x D	mm	818 x 316 x 189	818 x 316 x 189	975 x 354 x 209	975 x 354 x 209
		W x H x D	inch	32-7/32 x 12-7/16 x 7-7/16	32-7/32 x 12-7/16 x 7-7/16	38-3/8 x 13-15/16 x 8-7/32	38-3/8 x 13-15/16 x 8-7/32
	Shipping	W x H x D	mm	892 x 381 x 249	892 x 381 x 249	1,063 x 420 x 274	1,063 x 420 x 274
		W x H x D	inch	35-1/8 x 15 x 9-13/16	35-1/8 x 15 x 9-13/16	41-27/32 x 16-17/32 x 10-25/32	41-27/32 x 16-17/32 x 10-25/32
Weight	Body	kg (lbs)	8.2 (18.1)	8.2 (18.1)	11.4 (25.1)	12.0 (26.5)	
	Shipping	kg (lbs)	10.2 (22.5)	10.2 (22.5)	14.0 (30.9)	14.6 (32.2)	
Heat Exchanger	(Row x Column x Fins per inch) x No.	-	(2 x 23 x 22) x 1	(2 x 23 x 22) x 1	(2 x 16 x 20) x 1 + (1 x 8 x 22) x 1	(2 x 16 x 20) x 1 + (1 x 8 x 22) x 1	
	Face Area	m <sup>2</sup> (ft <sup>2</sup> )	0.20 (2.15)	0.20 (2.15)	0.28 (3.01)	0.28 (3.01)	
Fan	Type	-	Cross Flow Fan	Cross Flow Fan	Cross Flow Fan	Cross Flow Fan	
	Air Flow Rate	H / M / L	m <sup>3</sup> /min	7.7 / 6.4 / 5.0	8.1 / 6.7 / 5.3	14.2 / 11.3 / 9.9	15.2 / 12.7 / 10.2
		H / M / L	ft <sup>3</sup> /min	272 / 226 / 177	286 / 237 / 187	501 / 399 / 350	537 / 448 / 360
Fan Motor	Type	-	BLDC	BLDC	BLDC	BLDC	
	Output	W x No.	30 x 1	30 x 1	30 x 1	60 x 1	
Sound Pressure Level	H / M / L	dB(A)	36 / 32 / 27	38 / 34 / 29	44 / 38 / 34	46 / 41 / 36	
	Liquid	mm(inch)	Ø 6.35 (1/4)	Ø 6.35 (1/4)	Ø 6.35 (1/4)	Ø 6.35 (1/4)	
Piping Connections	Gas	mm(inch)	Ø 9.52 (3/8)	Ø 9.52 (3/8)	Ø 12.7 (1/2)	Ø 12.7 (1/2)	
	Drain	O.D. / I.D.	mm	Ø 21.5 / 16.0	Ø 21.5 / 16.0	Ø 21.5 / 16.0	
	Safety Devices	-	Fuse	Fuse	Fuse	Fuse	
Connections Method	-	-	Thermal Protector for Fan Motor	Thermal Protector for Fan Motor	Thermal Protector for Fan Motor	Thermal Protector for Fan Motor	
Power and Communication Cable (included Earth)	No. x mm <sup>2</sup>	-	4C x 0.75	4C x 0.75	4C x 0.75	4C x 0.75	

**Note:**

- Due to our policy of innovation, some specifications may be changed without notification
- Wiring cable size must comply with applicable local and national code.
- Sound level values are measured at noise measuring chamber in accordance with standard. Therefore, these values depend on ambient conditions and values are normally higher in actual condition.
- Capacities are net capacities based on the following conditions. Refer the outdoor unit specifications for calculating real capacity.
  - Cooling: Indoor Ambient Temp. 27 deg DB / 19 deg WB, Outdoor Ambient Temp. 35 deg DB / 24 deg WB
  - Heating: Indoor Ambient Temp. 20 deg DB / 15 deg WB, Outdoor Ambient Temp. 7 deg DB / 6 deg WB
- Interconnected pipe is standard length and difference of Elevation (Outdoor ~ Indoor unit) is Zero.
- In case Multi Type Indoor unit, actual performance data could be different via combination of indoor units and outdoor units.

## Wall Mounted Unit (Standard+)



Model Name			AMNQ09GSJB0	AMNQ12GSJB0	AMNQ18GSKB0	AMNQ24GSKB0	
Power Supply		V, Ø, Hz	220-240, 1, 50/60	220-240, 1, 50/60	220-240, 1, 50/60	220-240, 1, 50/60	
Power Input	Min./Nom./Max.	W	11 / 18 / 30	11 / 19 / 30	26 / 39 / 60	27 / 45 / 60	
Running Current	Min./Nom./Max.	A	0.10 / 0.16 / 0.20	0.10 / 0.17 / 0.20	0.22 / 0.28 / 0.40	0.24 / 0.33 / 0.40	
Casing Color		-	Munsell 7.5BG 10/2 (RAL 9016)	Munsell 7.5BG 10/2 (RAL 9016)	Munsell 7.5BG 10/2 (RAL 9016)	Munsell 7.5BG 10/2 (RAL 9016)	
Dimensions	Body	W x H x D	mm	837 x 308 x 189	837 x 308 x 189	998 x 345 x 210	998 x 345 x 210
		W x H x D	inch	32-15/16 x 12-1/8 x 7-7/16	32-15/16 x 12-1/8 x 7-7/16	39-9/32 x 13-19/32 x 8-9/32	39-9/32 x 13-19/32 x 8-9/32
	Shipping	W x H x D	mm	892 x 381 x 249	892 x 381 x 249	1,063 x 420 x 274	1,063 x 420 x 274
		W x H x D	inch	35-1/8 x 15 x 9-13/16	35-1/8 x 15 x 9-13/16	41-27/32 x 16-17/32 x 10-25/32	41-27/32 x 16-17/32 x 10-25/32
Weight	Body	kg (lbs)	8.8 (19.4)	8.8 (19.4)	11.3 (24.9)	12.0 (26.5)	
	Shipping	kg (lbs)	10.1 (22.3)	10.1 (22.3)	13.1 (28.9)	13.8 (30.4)	
Heat Exchanger	(Row x Column x Fins per inch) x No.	-	(2 x 15 x 21) x 1	(2 x 15 x 21) x 1	(2 x 16 x 20) x 1	(2 x 16 x 20) x 1	
	Face Area	m <sup>2</sup> (ft <sup>2</sup> )	0.19 (2.05)	0.19 (2.05)	0.24 (2.58)	0.24 (2.58)	
Fan	Type	-	Cross Flow Fan	Cross Flow Fan	Cross Flow Fan	Cross Flow Fan	
	Air Flow Rate	H / M / L	m <sup>3</sup> /min	9.2 / 7.4 / 5.6	9.6 / 8.1 / 5.6	15.8 / 12.4 / 10.0	16.9 / 12.8 / 10.4
		H / M / L	ft <sup>3</sup> /min	325 / 261 / 198	339 / 286 / 198	558 / 438 / 353	597 / 452 / 367
Fan Motor	Type	-	BLDC	BLDC	BLDC	BLDC	
	Output	W x No.	30 x 1	30 x 1	30 x 1	60 x 1	
Sound Pressure Level	H / M / L	dB(A)	36 / 33 / 27	40 / 35 / 27	44 / 38 / 34	46 / 41 / 36	
	Liquid	mm(inch)	Ø 6.35 (1/4)	Ø 6.35 (1/4)	Ø 6.35 (1/4)	Ø 6.35 (1/4)	
Piping Connections	Gas	mm(inch)	Ø 9.52 (3/8)	Ø 9.52 (3/8)	Ø 12.7 (1/2)	Ø 12.7 (1/2)	
	Drain	O.D. / I.D.	mm	Ø 21.5 / 16.0	Ø 21.5 / 16.0	Ø 21.5 / 16.0	
	Safety Devices	-	Fuse	Fuse	Fuse	Fuse	
Connections Method	-	-	Thermal Protector for Fan Motor	Thermal Protector for Fan Motor	Thermal Protector for Fan Motor	Thermal Protector for Fan Motor	
Power and Communication Cable (included Earth)	No. x mm <sup>2</sup>	-	4C x 0.75	4C x 0.75	4C x 0.75	4C x 0.75	

**Note:**

- Due to our policy of innovation, some specifications may be changed without notification
- Wiring cable size must comply with applicable local and national code.
- Sound level values are measured at noise measuring chamber in accordance with standard. Therefore, these values depend on ambient conditions and values are normally higher in actual condition.
- Capacities are net capacities based on the following conditions. Refer the outdoor unit specifications for calculating real capacity.
  - Cooling: Indoor Ambient Temp. 27 deg DB / 19 deg WB, Outdoor Ambient Temp. 35 deg DB / 24 deg WB
  - Heating: Indoor Ambient Temp. 20 deg DB / 15 deg WB, Outdoor Ambient Temp. 7 deg DB / 6 deg WB
- Interconnected pipe is standard length and difference of Elevation (Outdoor ~ Indoor unit) is Zero.
- In case Multi Type Indoor unit, actual performance data could be different via combination of indoor units and outdoor units.

# 1Way CEILING CASSETTE

## 6-Step Vane Control

There are 6 different steps to control air flow direction. Also 1 way cassette has vane to move auto swing between left and right as 120 degree.

### • Moving Air Flow\_1 Way cassette

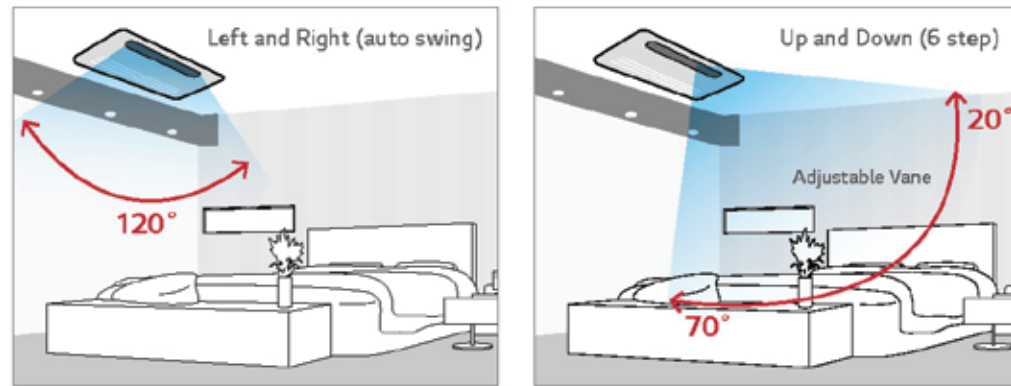

## Minimized Height

LG 1 Way cassette's height is 132mm and this is lowest level in the industry. This makes installation interference with other facilities inside the ceiling at minimum level.

### • Size Comparison

	LG	A company	B company
1 way cassette	132	215	230

(Unit: mm)

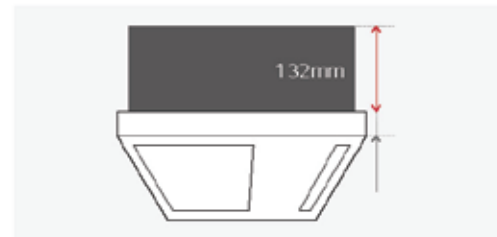

## Flexible Installation

The access for inspecting 1 way Cassette is possible through the front panel so it does not require additional inspection door making more simple environment.

### • 1 Way cassette



### • Duct

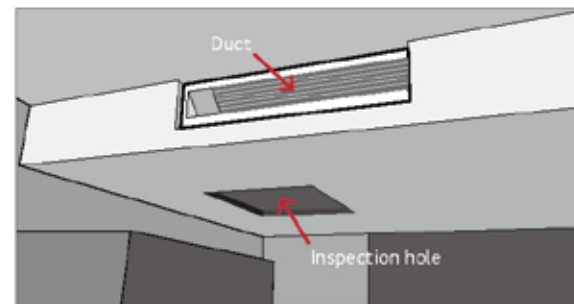

## 1 Way Ceiling Mounted Cassette



Model Name			AMNQ09GTUA0	AMNQ12GTUA0	AMNQ18GTTA0	AMNQ24GTTA0	
Power Supply		V, $\phi$ , Hz	220-240, 1, 50/60	220-240, 1, 50/60	220-240, 1, 50/60	220-240, 1, 50/60	
Power Input		W	-	-	-	-	
Running Current(Max.)		A	0.2	0.2	0.31	0.31	
Casing Color		-	-	-	-	-	
Dimensions	Body	W x H x D	mm	860 x 132 x 450	860 x 132 x 450	1,180 x 132 x 450	
		W x H x D	inch	33-27/32 x 5-3/16 x 17-23/32	33-27/32 x 5-3/16 x 17-23/32	46-15/32 x 5-3/16 x 17-23/32	
Weight	Body	kg (lbs)	11.7 (25.8)	11.7 (25.8)	14.5 (32.0)	14.5 (32.0)	
	Shipping	kg (lbs)	14.4 (31.7)	14.4 (31.7)	17.9 (39.5)	17.9 (39.5)	
Heat Exchanger	(Row x Column x Fins per inch) x No.	-	(2 x 12 x 18) x 1	(2 x 12 x 18) x 1	(2 x 12 x 18) x 1	(2 x 12 x 18) x 1	
	Face Area	m <sup>2</sup> (ft <sup>2</sup> )	0.18 (1.90)	0.18 (1.90)	0.24 (2.58)	0.24 (2.58)	
Fan	Type	-	Cross Flow Fan	Cross Flow Fan	Cross Flow Fan	Cross Flow Fan	
	Air Flow Rate	H / M / L	m <sup>3</sup> /min	7.5 / 7.3 / 6.8	8.1 / 7.4 / 7.0	13.3 / 11.8 / 10.8	14.0 / 13.3 / 11.8
		H / M / L	ft <sup>3</sup> /min	265 / 258 / 240	288 / 261 / 247	470 / 417 / 381	494 / 470 / 417
Fan Motor	Type	-	BLDC	BLDC	BLDC	BLDC	
	Output	W x No.	20 x 1	20 x 1	30 x 1	30 x 1	
Sound Pressure Level	H / M / L	dB(A)	36 / 34 / 32	37 / 36 / 33	41 / 39 / 36	44 / 41 / 39	
Sound Power Level	H / M / L	dB(A)	-	-	-	-	
Piping Connections	Liquid	mm(inch)	$\phi$ 8.35 (1/4)	$\phi$ 8.35 (1/4)	$\phi$ 8.35 (1/4)	$\phi$ 8.35 (1/4)	
	Gas	mm(inch)	$\phi$ 9.52 (3/8)	$\phi$ 9.52 (3/8)	$\phi$ 12.7 (1/2)	$\phi$ 12.7 (1/2)	
	Drain (O.D. / I.D.)	mm	$\phi$ 32.0 / 25.0	$\phi$ 32.0 / 25.0	$\phi$ 32.0 / 25.0	$\phi$ 32.0 / 25.0	
Safety Devices		-	Fuse		Fuse		
Power and Communication Cable (included Earth)		No. x mm <sup>2</sup> (AWG)	4C x 0.75 (18)	4C x 0.75 (18)	4C x 0.75 (18)	4C x 0.75 (18)	
Decoration Panel	Model Name	-	PT-UUC1	PT-UUC1	PT-UJC	PT-UJC	
	Casing Color	-	Morning Fog	Morning Fog	Morning Fog	Morning Fog	
	Dimensions	W x H x D	mm	1,100 x 34 x 500	1,100 x 34 x 500	1,420 x 34 x 500	1,420 x 34 x 500
		W x H x D	inch	43-5/16 x 1-11/32 x 19-11/16	43-5/16 x 1-11/32 x 19-11/16	55-29/32 x 1-11/32 x 19-11/16	55-29/32 x 1-11/32 x 19-11/16
	Net weight	kg (lbs)	4.4 (9.7)	4.4 (9.7)	5.0 (11.0)	5.0 (11.0)	

### Note:

- Due to our policy of innovation, some specifications may be changed without notification
- Wiring cable size must comply with applicable local and national code.
- Sound level values are measured at noise measuring chamber in accordance with standard. Therefore, these values depend on ambient conditions and values are normally higher in actual condition.
- Capacities are net capacities based on the following conditions. Refer the outdoor unit specifications for calculating real capacity.
  - Cooling: Indoor Ambient Temp. 27 deg DB / 19 deg WB, Outdoor Ambient Temp. 35 deg DB / 24 deg WB
  - Heating: Indoor Ambient Temp. 20 deg DB / 15 deg WB, Outdoor Ambient Temp. 7 deg DB / 6 deg WB
- Interconnected pipe is standard length and difference of Elevation (Outdoor - Indoor unit) is Zero.

# 4Way CEILING CASSETTE



## Wide Air Flow

Improved vanes reduce the curved area and provide better air and temperature distribution.

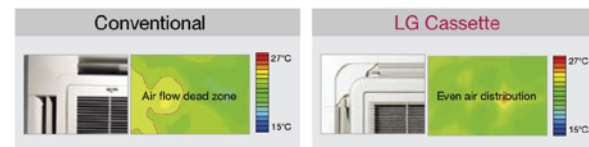

## Convenient Panel Installation

The detachable corner design makes it easy to adjust the hanger during installation and to check for leakages in the drain connection pipe.

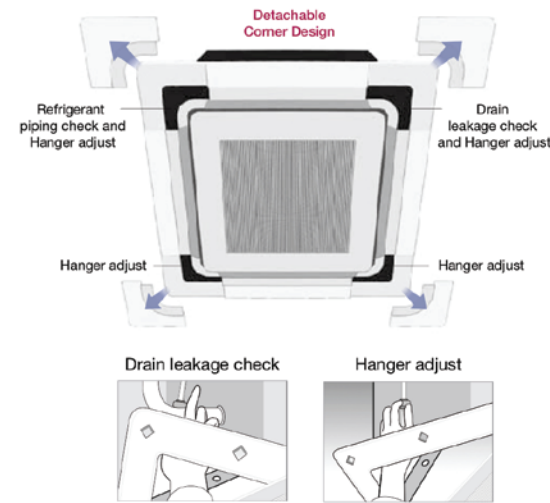

It is easy to install the panel to the body, using the button type panel design.



## Independent Vane Control

It is possible to control each of the 4 vanes individually as the motors are connected separately to each vane.



\* Wired remote controller PQRCVSL0QW applied

## Auto Elevation Grille (Optional)

Easy filter cleaning with elevation grill

- Installation inside main body
- Auto horizontal control
- 4 points support structure
- Memory for user's level
- Max 4.5m length
- Model : PTEGM0

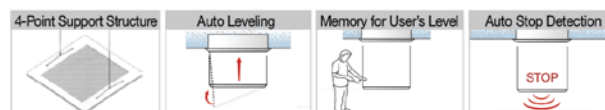
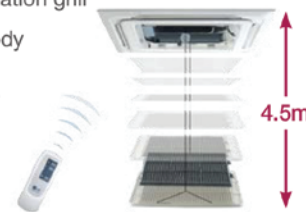

\* Operating with wired remote controller PQRCVSL0QW and wireless remote controller included in PTEGM0.

## 4 Way Ceiling Mounted Cassette

Model Name		AMNC12GTRA2	AMNC18GTQA2	AMNC24GTPA2	
Power Supply	V, Ø, Hz	220-240, 1, 50/60	220-240, 1, 50/60	220-240, 1, 50/60	
Power Input	Min / Nom / Max	-	-	-	
Running Current	A	0.35	0.43	0.60	
Casing Color	-	-	-	-	
Dimensions	Body	W × H × D	570 × 214 × 570	570 × 256 × 570	840 × 204 × 840
		W × H × D	22-7/16 × 8-7/16 × 22-7/16	22-7/16 × 10-3/32 × 22-7/16	33-1/16 × 8-1/32 × 33-1/16
Net Weight	Body	kg (lbs)	14.0 (30.9)	15.0 (33.1)	21.0 (46.3)
Heat Exchanger	(Row × Column × Fins per inch) × No.	-	(2 × 8 × 18) × 1	(2 × 8 × 19) × 1	(3 × 18 × 22) × 1
	Face Area	m <sup>2</sup> (ft <sup>2</sup> )	0.34 (3.61)	0.34 (3.61)	1.134 (12.2)
Fan	Type	-	Turbo Fan	Turbo Fan	Turbo Fan
	Air Flow Rate	H / M / L	9.5 / 8.0 / 6.5	13.0 / 12.0 / 10.0	17.0 / 15.0 / 13.0
Fan Motor	Type	-	BLDC	BLDC	BLDC
	Output	W × No.	43 × 1	43 × 1	60 × 1
Sound Pressure Level	H / M / L	dB(A)	35 / 31 / 27	40 / 37 / 34	39 / 37 / 34
Sound Power Level	H / M / L	dB(A)	-	-	-
Piping Connections	Liquid	mm(inch)	Ø 6.35 (1/4)	Ø 6.35 (1/4)	Ø 6.35 (1/4)
	Gas	mm(inch)	Ø 9.52 (3/8)	Ø 12.7 (1/2)	Ø 12.7 (1/2)
	Drain (O.D. / I.D.)	mm	Ø 32.0 / 25.0	Ø 32.0 / 25.0	Ø 32.0 / 25.0
Safety Devices	-	Thermal Protector for Fan Motor	Thermal Protector for Fan Motor	Thermal Protector for Fan Motor	
Power and Communication Cable (Included Earth)	No. × mm <sup>2</sup> (AWG)	4C × 0.75 (18)	4C × 0.75 (18)	4C × 0.75 (18)	
Decoration Panel	Model Name	-	PT-UQC	PT-UQC	PT-UMC(1)
	Casing Color	-	Morning Fog	Morning Fog	Morning Fog
	Dimensions	W × H × D	700 × 22 × 700	700 × 22 × 700	950 × 25 × 950
		W × H × D	27-9/16 × 7/8 × 27-9/16	27-9/16 × 7/8 × 27-9/16	37-13/32 × 31/32 × 37-13/32
Net weight	kg (lbs)	3.0 (6.6)	3.0 (6.6)	5.0 (11.0)	

### Note:

1. Due to our policy of innovation, some specifications may be changed without notification
2. Wiring cable size must comply with applicable local and national code.
3. Sound level values are measured at noise measuring chamber in accordance with standard. Therefore, these values depend on ambient conditions and values are normally higher in actual condition.
4. Capacities are net capacities based on the following conditions. Refer the outdoor unit specifications for calculating real capacity.
  - a. Cooling: Indoor Ambient Temp. 27 deg DB / 19 deg WB, Outdoor Ambient Temp. 35 deg DB / 24 deg WB
  - b. Heating: Indoor Ambient Temp. 20 deg DB / 15 deg WB, Outdoor Ambient Temp. 7 deg DB / 6 deg WB
5. Interconnected pipe is standard length and difference of Elevation (Outdoor - Indoor unit) is Zero.

# CEILING CONCEALED DUCTS



## Ceiling Concealed Duct

### Two Thermistors Control

The indoor temperature can be checked using the thermistors in the remote controller as well as from the indoor unit. There may be a significant difference between ceiling and floor air temperature. Two thermistors can optimise indoor air temperature for a more comfortable environment.

Compares temperatures sensed from different positions, and automatically selects the optimum temperature for users



### Operation for Multiple Rooms

Using a spiral duct (embedded or flexible type) and stream chamber, it is possible to operate cooling/heating for several rooms simultaneously.

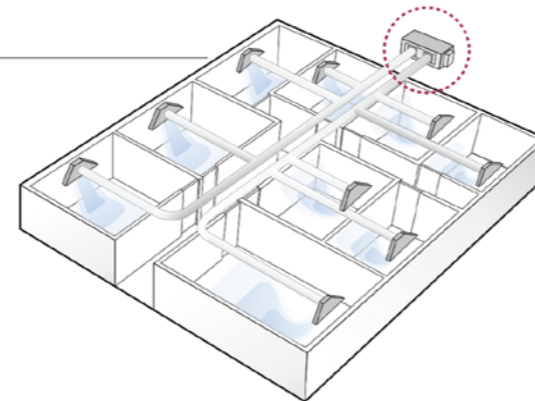

### E.S.P. Control

The BLDC motor and low noise fan means that air volume can be easily controlled by using the wired remote controller. The BLDC motor can control the fan speed and air volume regardless of the external static pressure (E.S.P.) With E.S.P. control no additional accessories are needed to adjust the air flow and the energy consumption of the fan is also reduced.

Air Volume

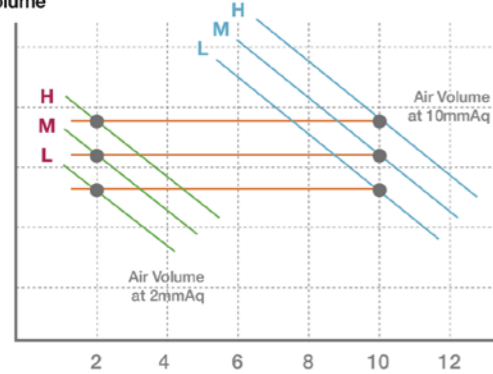

External Static Pressure (mmAq)  
\* Wired remote controller PQRCVSL0QW applied.

Model Name		AMNQ09GL1A0	AMNQ12GL2A0	AMNQ18GL2A0	AMNQ24GL3A0		
Power Supply		V, $\phi$ , Hz	220-240, 1, 50	220-240, 1, 50	220-240, 1, 50	220-240, 1, 50	
Power Input		W	50	95	120	150	
Running Current		A	0.40	0.80	0.80	1.00	
Dimensions	Body	W x H x D	mm	700 x 190 x 700	900 x 190 x 700	900 x 190 x 700	1,100 x 190 x 700
		W x H x D	inch	27-9/16 x 7-15/32 x 27-9/16	35-7/16 x 7-15/32 x 27-9/16	35-7/16 x 7-15/32 x 27-9/16	43-5/16 x 7-15/32 x 27-9/16
Net Weight		Body	kg (lbs)	17.5 (38.6)	23.0 (50.7)	23.0 (50.7)	27.0 (59.5)
Heat Exchanger		(Row x Column x Fins per inch) x No.	-	(2 x 11 x 14) x 1	(2 x 11 x 18) x 1	(2 x 11 x 18) x 1	(3 x 11 x 18) x 1
Face Area		m <sup>2</sup> (ft <sup>2</sup> )	0.12 (1.32)	0.17 (1.81)	0.17 (1.81)	0.21 (2.31)	0.21 (2.31)
Fan		Type	-	Sirocco	Sirocco	Sirocco	Sirocco
Air Flow	High-static Mode (Factory Set)	H / M / L	m <sup>3</sup> /min	9.0 / 7.0 / 5.5	10.0 / 8.5 / 7.0	15.0 / 12.5 / 10.0	20.0 / 16.0 / 12.0
		H / M / L	ft <sup>3</sup> /min	318 / 247 / 194	353 / 300 / 247	530 / 441 / 353	706 / 565 / 424
		External Static Pressure	Pa (mmAq)	24.5 (2.5)	24.5 (2.5)	24.5 (2.5)	24.5 (2.5)
Fan Motor		Type	-	BLDC	BLDC	BLDC	BLDC
Output		W x No.	19 x 1	19 x 1 + 5 x 1	19 x 1 + 5 x 1	19 x 2	19 x 2
Dehumidification Rate		l / h (pts/h)	1.1 (2.3)	1.2 (2.6)	1.7 (3.6)	2.2 (4.7)	
Sound Pressure Level		H / M / L	dB(A)	30 / 26 / 23	31 / 28 / 27	36 / 34 / 31	39 / 35 / 32
Sound Power Level		Max.	dB(A)	49	52	54	58
Piping Connections		Liquid	mm(inch)	$\phi$ 6.35 (1/4)	$\phi$ 6.35 (1/4)	$\phi$ 6.35 (1/4)	$\phi$ 6.35 (1/4)*
Gas		mm(inch)	$\phi$ 9.52 (3/8)	$\phi$ 9.52 (3/8)	$\phi$ 12.7 (1/2)	$\phi$ 12.7 (1/2)*	
Drain (O.D. / I.D.)		mm(inch)	$\phi$ 32.0(1-1/4) / 25.0(31/32)	$\phi$ 32.0(1-1/4) / 25.0(31/32)	$\phi$ 32.0(1-1/4) / 25.0(31/32)	$\phi$ 32.0(1-1/4) / 25.0(31/32)	
Safety Devices		-	-	Fuse	Fuse	Fuse	
Power and Communication Cable (included Earth)		No. x mm <sup>2</sup> (AWG)	4C x 0.75 (18)	4C x 0.75 (18)	4C x 0.75 (18)	4C x 0.75 (18)	

#### Note:

- Due to our policy of innovation, some specifications may be changed without notification
- Wiring cable size must comply with applicable local and national code.
- Sound level values are measured at noise measuring chamber in accordance with standard. Therefore, these values depend on ambient conditions and values are normally higher in actual condition.
- Capacities are net capacities based on the following conditions. Refer the outdoor unit specifications for calculating real capacity.
  - Cooling: Indoor Ambient Temp. 27 deg DB / 19 deg WB, Outdoor Ambient Temp. 35 deg DB / 24 deg WB
  - Heating: Indoor Ambient Temp. 20 deg DB / 15 deg WB, Outdoor Ambient Temp. 7 deg DB / 6 deg WB
- Interconnected pipe is standard length and difference of Elevation (Outdoor - Indoor unit) is Zero.
- In case Multi Type Indoor unit, actual performance data could be different via combination of indoor units and outdoor units.

# MULTI SPLIT

## REFERENCE SITES

### The Florence Tower 1, 2 & 3



Location	Style	Product type	Total Capacity
McKinley Hill, Taguig City	Luxury Condo	Multi Split	410 HP

### Señor Sto. Niño Hospital Inc.



Location	Style	Product type	Total Capacity
Camiling, Tarlac	Hospital	Multi Split	135 HP

\* Pictures are copied from the internet

### Donggwang Clark ODE County



Location	Style	Product type	Total Capacity
Clarkfield, Pampanga	Condominium	Multi Split	250 HP

### The Linden Suites



Location	Style	Product type	Total Capacity
Ortigas Center, Pasig	Hotel	Multi Split	200 HP